



**Strathmore**  
UNIVERSITY

**SU+ @ Strathmore**  
**University Library**

---

**Electronic Theses and Dissertations**

---

2023

# A Smart water management system for detecting household water wastage.

Gichuhi, Janice Muringo  
*School of Computing and Engineering Sciences*  
*Strathmore University*

## **Recommended Citation**

Gichuhi, J. M. (2023). *A Smart water management system for detecting household water wastage* [Strathmore University]. <http://hdl.handle.net/11071/13535>

Follow this and additional works at: <http://hdl.handle.net/11071/13535>

# **A Smart Water Management System for Detecting Household Water Wastage**



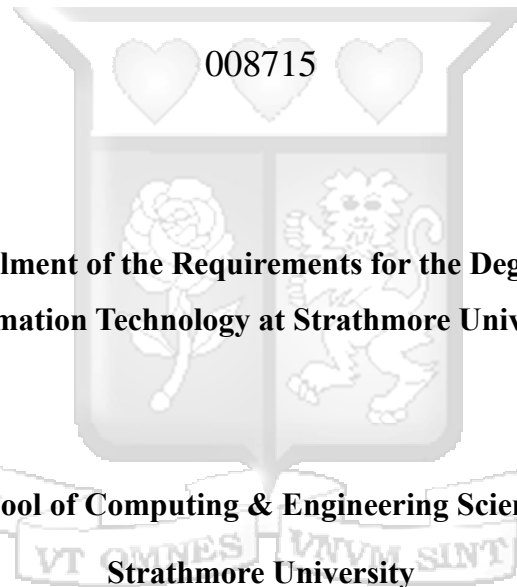
**Master of Science in Information Technology**

**2023**

# **A Smart Water Management System for Detecting Household Water Wastage**

By

Janice Muringo Gichuhi



**Submitted in Partial Fulfillment of the Requirements for the Degree of Master of Science in  
Information Technology at Strathmore University**

**School of Computing & Engineering Sciences  
Strathmore University**

**Nairobi, Kenya**

**July, 2023**

This thesis is available for Library use on the understanding that it is copyright material and that no quotation from the thesis may be published without proper acknowledgement

## Declaration and Approval

### Declaration

I declare that this work has not been previously submitted and approved for the award of a degree by this or any other University. To the best of my knowledge and belief, the thesis contains no material previously published or written by another person except where due reference is made in the thesis itself.

© No part of this thesis may be reproduced without the permission of the author and Strathmore University

Student's Name: Janice Muringo Gichuhi

Sign:  Date: 25th May 2023

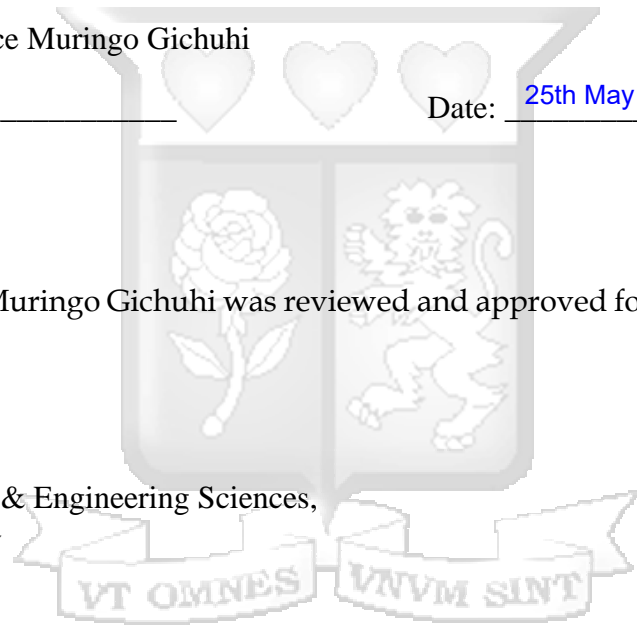
### Approval

The thesis of Janice Muringo Gichuhi was reviewed and approved for examination by the following:

Dr. Esther Khakata,  
School of Computing & Engineering Sciences,  
Strathmore University

Dr. Julius Butime,  
Dean, School of Computing & Engineering Sciences,  
Strathmore University

Dr. Bernard Shibwabo,  
Director of Graduate Studies,  
Strathmore University



## Abstract

Water scarcity in Kenya is a significant issue that cannot be overlooked. Despite numerous efforts made by Water Service Providers in delivering water services to Kenyan residents, the high demand for accessible water across the country remains unmet. In addition, the provider's ability to meet this demand is further impeded by various obstacles including inadequate control over water usage, insufficient resources to manage and conserve water, and the dilapidated water infrastructure within the Nation. As global water resources rapidly decline, due to the effects of climate change and overuse, it is crucial to take action in conserving this resource. This study looks into the development of a smart water management system using water flow sensors connected directly to the water appliances, Node MCU microcontrollers and a cloud-based application. The system focuses on monitoring household water usage frequency to inform users of their consumption and alert them via mobile notifications of potential water leaks to reduce wastage. Management and control of household water consumption is a positive step towards impacting water conservation efforts.

Keywords: Internet of Things, Machine Learning, Usage Detection, Leakage Detection, Smart Water Management System



## Table of Contents

<b>Declaration and Approval</b> .....	ii
Abstract.....	iii
List of Figures.....	x
List of Tables.....	xiii
List of Abbreviations.....	xiv
Acknowledgements.....	xv
Chapter 1 : Introduction.....	1
1.1 Background of the Study.....	1
1.2 Problem Statement.....	3
1.3 Objectives.....	4
1.3.1 General Objective.....	4
1.3.2 Specific Objectives.....	5
1.3.3 Research Questions.....	5
1.4 Justification.....	5
1.5 Scope and Limitations.....	6
Chapter 2 : Literature Review.....	7
2.1 Introduction.....	7
2.2 Theoretical Literature.....	7

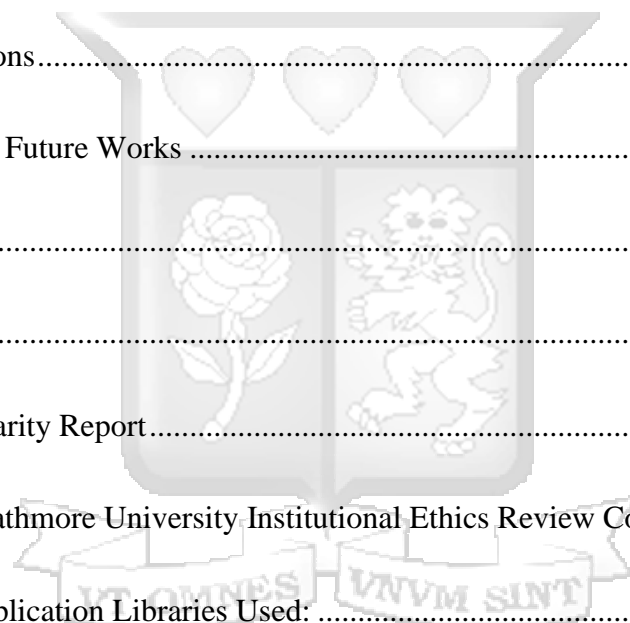
2.2.1 Water Wastage Identification .....	8
2.2.2 Behavioural change techniques in water management .....	9
2.3 Empirical Literature .....	13
2.3.1 Smart Water Management System in India .....	14
2.3.2 A wireless household water consumption monitoring system in Europe .....	16
2.3.3 Smart Water Meter System for User-Centric Consumption Measurement South Africa .....	17
2.3.4 Water Management in Athens and Warsaw .....	20
2.3.5 Water Management in Nairobi.....	23
2.3.6 IoT-Based Water Leakage Detection Using Smart Objects for Smart City .....	25
2.3.7 Smart Residential Water Leak and Overuse Detection System.....	26
2.4 Models for water usage management .....	28
2.4.1 Descriptive models.....	28
2.4.2 Predictive models.....	28
2.4.3 Artificial Neural Networks .....	29
2.4.4 ARIMA Based Framework .....	30
2.5 Algorithms for Water Management .....	30
2.5.1 Weather-Based Algorithms.....	31

2.5.2 Demand-Based Algorithms.....	31
2.5.3 Network-Level Algorithms.....	31
2.5.4 Leak-Detection Algorithms .....	31
2.6 Internet of Things (IoT) and IoT Architecture.....	32
2.6.1 Wireless Technologies in Internet of Things .....	34
2.7 Smart water management and system information flow.....	35
2.8 Conceptual Framework.....	37
Chapter 3 : Research Methodology.....	39
3.1 Introduction.....	39
3.2 System Development Methodology.....	39
3.3 Research Design.....	41
3.3.1 Location of the study .....	41
3.3.2 Sample population .....	42
3.3.3 Data collection procedure .....	42
3.3.4 Data Analysis .....	44
3.4 System Analysis.....	46
3.4.1 Context Diagram.....	47
3.4.2 Data flow diagrams.....	47

3.4.3 Use case diagrams.....	47
3.4.4 Sequence diagrams.....	48
3.5 System Implementation .....	48
3.6 Testing and Validation.....	48
3.7 Dissemination and Utilization of Results .....	48
3.8 Ethical Issues .....	49
Chapter 4 : System Analysis, Design & Architecture.....	50
4.1 Introduction.....	50
4.2 Requirements Analysis .....	50
4.2.1 Functional Requirements .....	50
4.2.2 Usability Requirements.....	51
4.2.3 Supportability Requirements .....	51
4.2.4 Non-functional Requirements.....	51
4.3 Application Architecture.....	52
4.4 System Design .....	54
4.4.1 Use Case Diagram.....	54
4.4.2 Sequence Diagram .....	57
4.4.3 Data flow diagram.....	58

4.4.4 Entity Relationship Diagram.....	59
4.4.5 Wireframes.....	60
Chapter 5 : System Implementation and Testing.....	62
5.1. Introduction.....	62
5.2. Hardware Environment.....	62
5.3 Software Environment.....	64
5.4 Roles and Permissions.....	64
5.5 System Modules.....	65
5.6 Hardware Configuration and Uploads.....	68
5.7 System testing and application.....	70
5.7.1 Unit and Functional Testing.....	70
5.7.3 Usability Testing.....	73
5.7.4 Integration Testing.....	73
5.7.5 Validation.....	74
Chapter 6 : Discussion.....	79
6.1 Introduction.....	79
6.2 A Comparative Analysis of Water Management Systems.....	79
6.3 Challenges Hindering Management of Water Usage and Wastage.....	79

6.4 Detecting Water Wastage Using a Smart Water Management System .....	80
6.5 Testing the Performance of the System .....	82
6.6 Practical Implications.....	83
6.7 Limitations of the System .....	83
Chapter 7 : Conclusion and Recommendations .....	85
7.1 Conclusion .....	85
7.2 Recommendations.....	85
7.3 Suggestions for Future Works .....	86
REFERENCES .....	87
APPENDICES .....	92
Appendix A: Similarity Report.....	92
Appendix B: Strathmore University Institutional Ethics Review Committee Approval .	93
Appendix C: Application Libraries Used: .....	94



## List of Figures

Figure 2.1(Kenya Renewable Water Resources, 1961-2017 - Knoema.Com, n.d.).....	8
Figure 2.2 Effects of water-saving strategies.....	13
Figure 2.3 Architecture Diagram for the Smart Water Management System.....	15
Figure 2.4 System Architecture (Yang et al., 2017) .....	16
Figure 2.5 Water consumption analysis.....	18
Figure 2.6 Cumulative water consumption.....	19
Figure 2.7 Water Consumption Comparison .....	19
Figure 2.8 Motivation of efficient water use in Greece and Poland .....	21
Figure 2.9 Water Conservation attitudes in Greece .....	22
Figure 2.10 Water conservation attitudes Poland .....	22
Figure 2.11 Distribution of storage capacity for water conservation systems.....	24
Figure 2.12 Function benefits .....	24
Figure 2.13 Benefit-cost ratio of water conservation systems.....	25
Figure 2.14(Sethi & Sarangi, 2017) IOT architecture .....	33
Figure 2.15(“Smart Water Flow Control and Monitoring System,” 2018) .....	36
Figure 2.16 Information Flow (Kamaruidzaman & Nazahiyah Rahmat, 2020).....	37

Figure 2.17 Conceptual Diagram for the system .....	38
Figure 3.1 Iteration method.....	40
Figure 3.2 Iteration Process (Srivastava et al., 2017) .....	40
Figure 3.3 Sample code for data collection and upload.....	43
Figure 3.4 Display on the serial monitor showing data collection .....	43
Figure 3.5 Weekly volume analysis.....	45
Figure 3.6 Comparing average volumes with actual volume .....	45
Figure 3.7 Real-time flow rate .....	46
Figure 4.1 Application Architecture .....	54
Figure 4.2 Use Case Diagram .....	55
Figure 4.3 Sequence Diagram.....	57
Figure 4.4 Level 1 Data flow diagram .....	58
Figure 4.5 Entity Relationship Diagram .....	59
Figure 4.6 Login, Dashboard .....	60
Figure 4.7 Alerts .....	61
Figure 5.1 NodeMCU attached to breadboard.....	64
Figure 5.2 Module for managing users and devices .....	65

Figure 5.3 Login and Registration module.....	66
Figure 5.4 User Dashboard.....	67
Figure 5.5 Events and alerts generator module.....	68
Figure 5.6 Compiling and uploading of code to the Node MCU.....	69
Figure 5.7 Sample of real-time data from the Arduino IDE serial interface.....	70
Figure 5.8 Prototype connected to the bathroom to monitor consumption.....	71
Figure 5.9 Dashboard when no water is flowing.....	75
Figure 5.10 Dashboard as Water is Flowing.....	76
Figure 5.11 Dashboard graphs.....	77
Figure 5.12 Blynk mobile alert.....	78
Figure 5.13 Different alerts and Notifications.....	78
Figure 6.1 Kitchen Data analysis graph.....	81
Figure 6.2 Bathroom Analysis.....	82

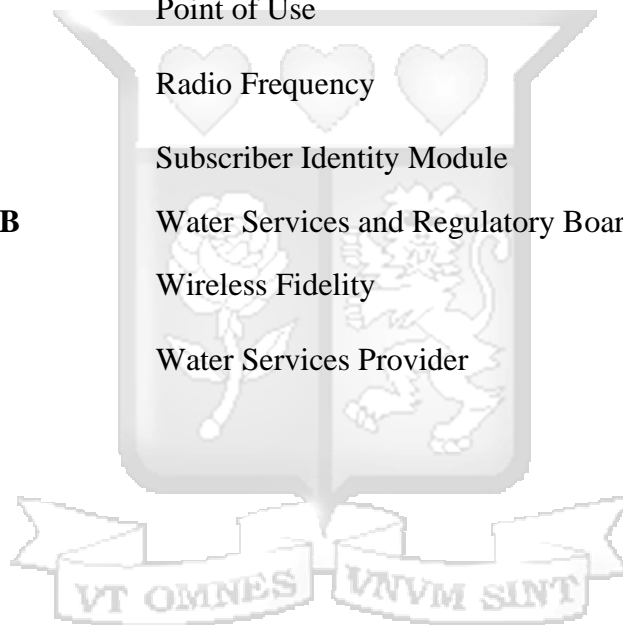
## List of Tables

Table 2.1 Flow of Data forecast based on ARIMA .....	30
Table 4.1 Use Case Descriptions .....	56
Table 5.1 The core hardware components .....	63
Table 5.2 Functional Testing .....	72
Table 5.3 Compatibility Testing Results .....	73



## List of Abbreviations

<b>ASAL</b>	Arid and Semi-Arid Land
<b>BLE</b>	Bluetooth Low Energy
<b>GSM</b>	Global System for Mobile Communication
<b>IDE</b>	Integrated Development Environment
<b>IoT</b>	Internet of Things
<b>PoU</b>	Point of Use
<b>RF</b>	Radio Frequency
<b>SIM</b>	Subscriber Identity Module
<b>WASREB</b>	Water Services and Regulatory Board
<b>Wi-Fi</b>	Wireless Fidelity
<b>WSP</b>	Water Services Provider



## **Acknowledgements**

I express my sincere gratitude to all the people who offered their assistance and encouragement during the development of this study. A special appreciation goes out to my supervisor Dr. Esther Khakata for her overwhelming support in improving my research work and creating a flexible and warm environment for need-based consultation.

I extend my deep gratitude to my beloved family and friends for their continuous support. God bless you all.



# **Chapter 1 : Introduction**

## **1.1 Background of the Study**

Kenya is ranked as a water-scarce nation by the United Nations due to the fact that the water demand surpasses its renewable freshwater supply. The country has one of the lowest water replenishment rates in the world, with its “renewable water resources per capita standing at 617 cubic metres per year against a global benchmark of 1000 cubic metres per year” (“Kenya Markets Trust,” 2021). This resource is declining at a moderate rate and is expected to worsen in the future. Kenya's water is used for direct purposes, such as drinking, cooking, cleaning and washing, as well as indirect purposes, such as agriculture, manufacturing and electricity production. Agriculture uses the bulk of Kenya's water, followed by municipal use (household use) and then industrial use (AQUASTAT, 2019).

In 2010, Kenya adopted a new constitution that guarantees every person the right to clean and safe water in adequate quantities. However, audits published by the Water and Sanitation Regulatory Board and the Ministry of Water countrywide, have raised concerns about the constant rise in water wastage through leaks, burst pipes, illegal connections and inefficient use of water. Tackling this water wastage is a high priority for the water sector in Kenya, as it adds to the strain already experienced due to the decline of renewable water sources and the increase in water demand for the entire nation. Strategizing to reduce this water wastage is outlined in Kenya's Vision 2030, Sustainable Development Goal 6, and Kenya's National Water Strategy report, 2015.

The water sector in Kenya has undergone numerous transformations, including the enactment of the Water Act 2016, which became operational in April 2017. The new law aligns national water management and water services provision with the requirements of the Constitution of Kenya, 2010. Service provision is devolved to the counties that are the owners of Water Service Providers (WSPs). The WSP company is mandated to provide clean water and sewerage

services to the residents of their respective counties in a financially sustainable manner and within government regulations. The Water Services and Regulatory Board (WASREB) governs all County WSP companies. The board not only ensures that consumers are protected and have access to efficient, affordable and sustainable services but also, provides for the financial sustainability of Water Service Providers (WSPs), by allowing financing of operations, capital cost recovery and a return on capital that sustains services through ongoing investments (WASREB, 2021).

Devolving these services to the counties has played a key role in the journey to Vision 2030, which aims at transforming Kenya into a middle-income country providing high quality of life to all its citizens in a clean and secure environment. The water and sanitation component of Vision 2030 objectives include ensuring that there is improved water and sanitation available and accessible to all, increasing access to safe water and sanitation in both rural and urban areas beyond the present levels, and raising the standards of the country's overall water resource management, storage and harvesting capability while reducing unaccounted water (wasted water) to below 30%.

According to WASREB impact report, water wastage in residential areas is highly prevalent, with 45% of water supplied to residential homes and cities annually wasted through improper use. Half of this water is lost through leaks, burst pipes, theft and meter inaccuracies. In Kenya, traditional water meter systems are used to calculate the water used per household. An employee from the water service provider is sent to read the meter and a monthly bill is sent to the consumer. Any disparity in the water meter readings requires proof from the consumer, which can be difficult to provide.

Managing and controlling water usage effectively and efficiently requires both behavioural and technological changes regarding how users consume water. Public Private Partnerships (PPPs) between private parties and government agencies have played a big role in the water sector focusing on water resource management (World Bank Group, 2021). Behavioural changes can be achieved through consumer training, daily water usage reports in public media platforms,

practical engagement by local leaders through campaigns to teach individuals about the effective use of household water, and printing stickers at various water outlets to educate users on good water use habits.

A recent webinar held on Zoom platform (Investing in Water Enterprises in Kenya, 2021) facilitated by the Water Sector Trust Fund, clearly stated that there is a huge misconception by the general public that water is free, while it is not. This misconception needs to be corrected so that consumers are aware that water, although a natural resource is being misused and rapidly declining. Technological changes can be achieved through accurate tracking of water through infrastructure investment, detailed measuring of water outlets, and monitoring of water usage and wastage. Accurate tracking of water can be done by the use of smart water sensors at various outlets.

In our current setup, many Kenyan citizens do not know the volume of water they use daily as no measurement is done in real-time at each water outlet. One study conducted by the World Bank to promote water conservation in Colombia found that daily monitoring of household water consumption and provision of daily reports to the public caused a shift in behaviour on how water was used. This shift resulted in a decline in water wastage and water savings of up to 14% (World Bank Group, 2015).

The smart water management system in this study aims at monitoring water usage at different water outlets to create consumption awareness in homes and send instant alerts in cases where water wastage is detected.

## **1.2 Problem Statement**

Water rationing in Kenya is a term all citizens have grown accustomed to. Notices and announcements made by water service providers of major cities, citing areas that are bound to experience rationing are published on several media forums. Most of these notices are regularly ignored as residents of these cities are familiar with irregular supply of water. The growing

population and the increase of rural to urban migration have led to a high demand for water that the providers are unable to meet. Many have resorted to buying from private water vendors who sell their water at unregulated costs and the quality of water supplied cannot be confirmed to be safe for household use. According to (Water.org, 2021), 32% of Kenyans depend on unimproved water sources like rivers, ponds, and shallow wells, whereas 48% of the population does not have access to basic sanitation facilities. Transforming the current infrastructure and automating the systems that aid in real-time monitoring of water usage and wastage is a necessary change towards managing this scarce resource. Areas in which water wastage is rampant need to be tracked and analysed.

Existing research in the field of smart water management systems has primarily focused on broader aspects including overall water monitoring, water billing, utility mapping, and meter accuracy. A notable gap however exists in narrowing down to the precise detection and monitoring of household water wastage at the individual appliance or fixture level. There's an outstanding absence of robust techniques and algorithms capable of effectively identifying patterns of wastage, such as leaks, excessive consumption, and inefficient usage at the appliance level, which impedes the implementation of targeted water conservation strategies. This research gap necessitates the development of a cost-friendly, easy-to-use, innovative system that can accurately detect and analyse household water wastage in real time, enabling proactive intervention and promoting prudent water consumption behaviour in the home and community.

## **1.3 Objectives**

### **1.3.1 General Objective**

The purpose of this study is to develop a system that will monitor water usage using a smart water management system and alert users of wastage and potential leaks.

### **1.3.2 Specific Objectives**

- i. To analyse the different water management systems in use.
- ii. To identify the challenges that impede water usage and wastage monitoring.
- iii. To develop a smart water management system that will detect water wastage in homes.
- iv. To test the system in giving real-time water usage and water wastage information.

### **1.3.3 Research Questions**

- i. What are the different water management systems in use?
- ii. What are the challenges that impede monitoring of water usage and wastage?
- iii. How can a smart water management system that detects household water wastage be developed?
- iv. How can the developed system be tested?

### **1.4 Justification**

The research focuses on identifying areas where water wastage is prevalent. The adoption and endorsement of this knowledge will enable home occupiers, residential developers and owners implement modern ways of conserving water, leading to reduced wastage. This may be in the forms of modernizing water infrastructure, implementing tools for alerting users on potential water wastage and automating water recycling methods.

Water and sanitation programs and NGOs can use the prototype to justify the funding given to the water sector. They can use this tool as a guide for monitoring and evaluating the best practice techniques for conserving and optimizing water usage.

Academicians will use this study as a foundation to further research and identify improvements to the prototype; either by extending the study or using it in a different field.

## 1.5 Scope and Limitations

The scope of this study was limited to formal residential homes in Nairobi, Kenya. These areas have structured architectural layouts of their drainage systems with appropriate water outlets that would facilitate the implementation of the prototype to enable collection of water consumption data from the different faucets via wireless connections. The two water outlets where the water flow sensors were installed were the kitchen and bathroom areas.



## Chapter 2 : Literature Review

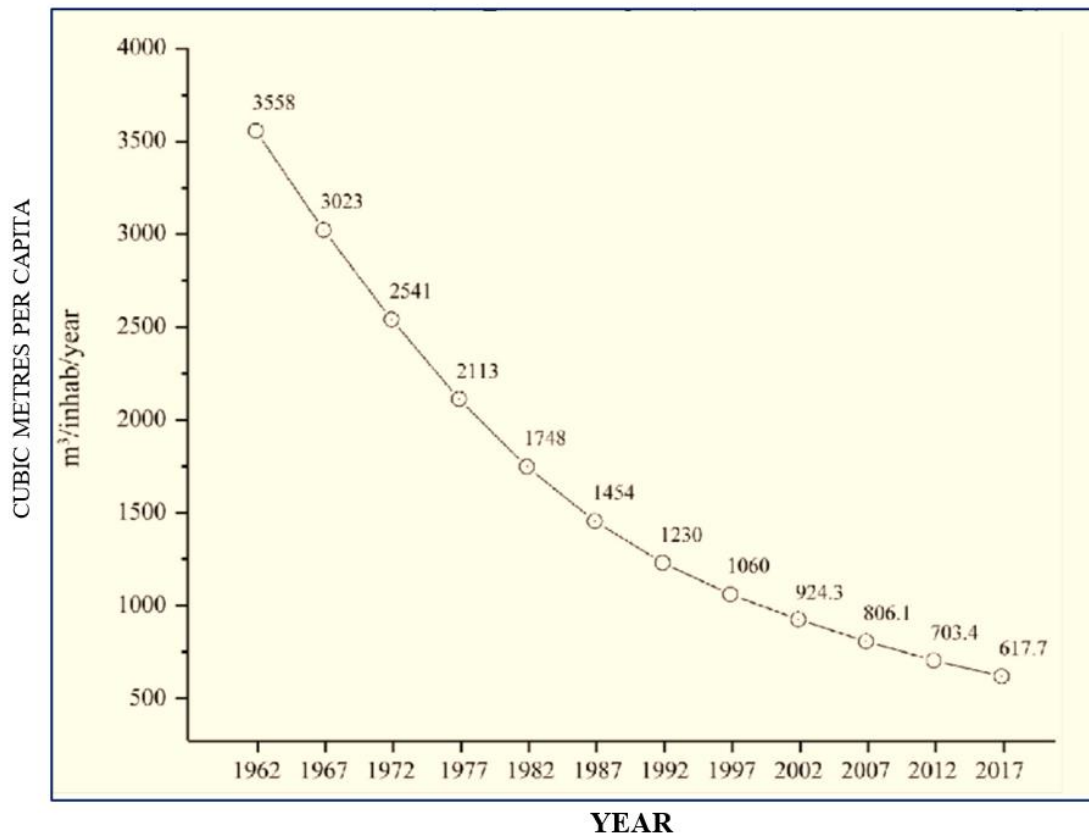
### 2.1 Introduction

This chapter discusses the various water management practices so as to identify the gaps. In addition to this, the different water management systems currently in use and their limitations will be looked into, together with the recommended approaches focusing on efficiency and integration with current systems.

### 2.2 Theoretical Literature

All living beings depend on water for survival and how we use it affects us all. Scientific studies have shown that about 70% of the earth's surface is covered with water, while this may seem abundant the reality is that only 1% is available for human consumption (World Wildlife Fund, 2021). This situation leaves the entire planet fending for this limited resource. To avoid complete depletion or severe scarcity of any limited resource, it is necessary to utilize it efficiently and effectively. Arid and semi-arid lands (ASALs) face this adverse effect of water scarcity. "The annual rainfall in arid areas ranges between 150 mm and 550 mm and in semi-arid areas between 550 mm and 850 mm per year" ( State Department For Arid and Semi Arid Lands Kenya, 2019). Kenya falls into the category of ASALs.

Figure 2.1 shows the trend in Kenya's renewable water resources over a span of fifty-five years. The trend is only getting worse.



**Figure 2.1(Kenya Renewable Water Resources, 1961-2017 - Knoema.Com, n.d.)**

In a recent study on Emotions toward water consumption, conservation and wastage, it was found that people’s perceptions of water consumption were based on social externalities. When consumers realize that water is being conserved in their environment then they were likely to conserve it and use it efficiently. On the other hand when an individual observes that the people in the environment are wasting water, then they are more likely to waste the water as well (de Miranda Coelho et al., 2016).

### **2.2.1 Water Wastage Identification**

Household water wastage refers to the excessive or inefficient use of water within a household setting. This can occur through actions such as leaving taps running unnecessarily, taking long

showers, using potable water for non-potable purposes, and over-watering plants or lawns. Such practices lead to a strain on the local water supply and treatment system. The United Nations Environment Programme reports that the average Kenyan household consumes between 100-200 litres of water per day, while the recommended usage rate is 70 litres per day. This means that most households are consuming more water than is necessary. According to a report by the United Nations Environment Programme, common causes of household water waste in Kenya include underutilization of modern plumbing and faulty plumbing systems, inefficient fixtures, poor irrigation practices, and lack of rainwater harvesting. Kenyan Ministry of Water and Sanitation and the Water Resources Management Authority have highlighted several water conservation measures that Kenyan households can take to reduce their water consumption, such as the use of greywater harvesting and the installation of water-efficient fixtures, though this is not being implemented (Dawson et al., 2014).

### **2.2.2 Behavioural change techniques in water management**

According to (Moglia et al., 2018a), the demonstration of behavioural change techniques was founded on three key pillars. These pillars encompassed understanding the factors that impact an individual's decision to conserve water, exploring what motivates individuals to persist with water conservation behaviour, and identifying the elements that contribute to awareness and familiarity of water conservation behaviours at an international level. One of the pillars- awareness and familiarity, focuses on making people cognizant of and acquainted with water conservation practices and the extent to which this awareness translates into reduced water wastage behaviour. The emphasis is on the active decision-making process that governs an individual's decision to undertake a particular behaviour. The second pillar, adoption, on the other hand, examines the factors that influence individuals to consider water conservation practices and eventually adopt them. Persistence is also examined, taking a long-term view of whether individuals who have adopted these practices will continue with the same behaviour over time. (Fielding et al., 2012)) argue that understanding these pillars is critical in designing effective behavioural change techniques that promote water conservation practices.

### 2.2.2.1 Awareness and Familiarity

Understanding the importance of water conservation and ways to reduce demand are the primary drivers for households to use water efficiently. However, a survey conducted in Jaipur City, India, found that the lack of knowledge on water conservation measures, such as rainwater harvesting, hampered uptake (Ramsey et al., 2017). To encourage water-saving behaviours, public messaging campaigns and government-led initiatives have been effective in improving water security and motivating citizens to conserve water. Educational campaigns that teach easy ways to conserve water may also increase self-efficacy and willingness to reduce water consumption (Thomas & Sharp, 2013).

The regular media attention around drought and the need for water conservation have been shown to reduce water use by 11-18% in California between 2010 and 2015. These results highlight the importance of effective public awareness and education on water demand behaviour and management (Quesnel & Ajami, 2017). However, the exact mechanisms that trigger water use behaviour are still largely unexplored, particularly outside of drought. Public awareness campaigns promoting water conservation practices are typically launched in response to drought episodes and wound down once the threat recedes. It would be worthwhile to explore how the effectiveness of such campaigns can be maximized both during drought crises and outside of them (Moglia et al., 2018a).

To encourage water conservation, it is essential to raise awareness of the importance of the resource and educate people on ways to reduce demand. A lack of knowledge on water conservation measures can hamper uptake, and therefore, public messaging campaigns and government-led initiatives can be effective in motivating citizens to conserve water. Educational campaigns that teach easy ways to conserve water can also increase self-efficacy and willingness to reduce water consumption. The regular media attention around drought and the need for water conservation have been effective in reducing water use, highlighting the importance of public awareness and education in water demand behaviour and management. However, the mechanisms that trigger water use behaviour are still largely unexplored, and it

is essential to explore how the effectiveness of public awareness campaigns can be maximized both during drought crises and outside of them.

#### **2.2.2.2 Adoption**

The decision to conserve water is influenced by various contextual factors, such as the cost of water, household characteristics, and social norms. A study in Namibia suggested that pricing was critical in reducing urban water demand, but the effectiveness of block tariffs was overestimated. In Australia, changes in water conservation behaviour were observed during droughts and water rationing periods when water was highly restricted and charged. Similarly, in France, increasing residential water prices by 10% resulted in a 7% reduction in water consumption among households in Andorra.

Higher-income was found to be associated with higher water demand, and larger households and older households were inclined to use more water. A survey of urban households in India found that water conservation efforts that required some level of effort, but no financial cost were less popular than those that did not require behavioural change. Therefore, the perception of inconvenience and impracticality, as well as the costs associated with water-saving appliances, may serve as important barriers to the adoption of water conservation behaviours.

Objective water usage data and surveys were collected from 1008 households in southeast Queensland, Australia, to identify key determinants of household water use and factors that could be targeted in a water demand management campaign. Results indicated that demographic, psychosocial, and behavioural factors, as well as households in regions recently exposed to drought conditions and higher-level restrictions, influenced water use. Households that reported a stronger culture of water conservation also used less water. These findings highlight the value of policies that support long-term cultural shifts in the way people think about and use water.

In Indian households, water conservation behaviour was most likely among those that considered it a community expectation and did not view the government as solely responsible for providing water security during droughts. However, a survey of over 200 households in Jaipur City found that a lack of know-how when it came to conserving water, including rainwater harvesting, hindered the uptake of water conservation efforts. Public messaging campaigns and government-run water conservation initiatives, as well as educational campaigns teaching easy ways to conserve water, may increase feelings of self-efficacy and willingness to reduce water consumption. The effectiveness of public awareness campaigns promoting water conservation practices warrants further exploration, particularly during and outside of drought crises.

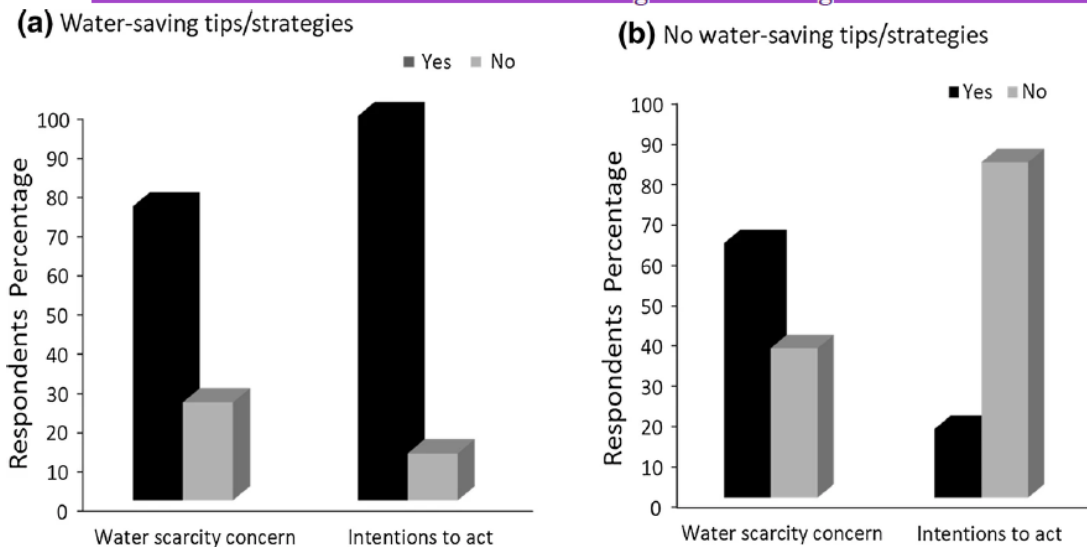
### **2.2.2.3 Persisting with Water Conservation Behaviours**

Water conservation techniques can lead to individuals persisting with water-saving behaviours in ideal situations. Globally, there has been a decline in per-capita water use, with several cities in the US and Canada reporting a decrease. Australian cities also experienced a reduction in residential water use during the drought, with significant declines ranging from 5% in Perth to 48% in Brisbane. Cities in Botswana and South Africa have also reported reduced per-capita potable water use (Brelsford & Abbott, 2017; Rutherford & Finlayson, 2011; Setlhogile et al., 2017).

The reasons for the decline in per-capita water use are varied and include the adoption of water-efficient appliances, reduced outdoor water use, and greater awareness of the need to conserve water resources during droughts. Targeted water conservation efforts have also contributed to reducing per-capita water use in many instances. However, water planners face the challenge of understanding how to achieve persistent behaviour change in water conservation other than during droughts, as evidenced by a bounce-back in residential water demand in California after the first year of a water demand reduction campaign (Moglia et al., 2018a).

To achieve persistent behaviour change in water conservation other than during droughts, it is crucial to understand the reasons behind the initial success of conservation efforts and how to sustain them over time. Despite the significant reduction in residential water demand observed in California after the first year of a water demand reduction campaign, a bounce-back in demand occurred after two years, **highlighting the need for sustained efforts to conserve water**. Thus, water planners must continually evaluate and improve their conservation programs to ensure that they can achieve lasting behaviour change and promote water conservation during and after droughts (Moglia et al., 2018a).

From: [The influence of water-conservation messages on reducing household water use](#)



Effects of **a** water-saving tips/strategies and **b** no water-saving tips/strategies message types on water scarcity concern and intentions to act. Yes and No indicate whether message types influence water scarcity concern and intentions to act

**Figure 2.2 Effects of water-saving strategies**

### 2.3 Empirical Literature

(Hasan et al., 2021), advocate for the use of smart technologies employed in the behavioural sciences to “nudge” people towards better water use behaviour through strategic, targeted

interventions towards individual commitments to water conservation. This ensures that users are always aware of their consumption patterns and are bound to use water efficiently.

### 2.3.1 Smart Water Management System in India

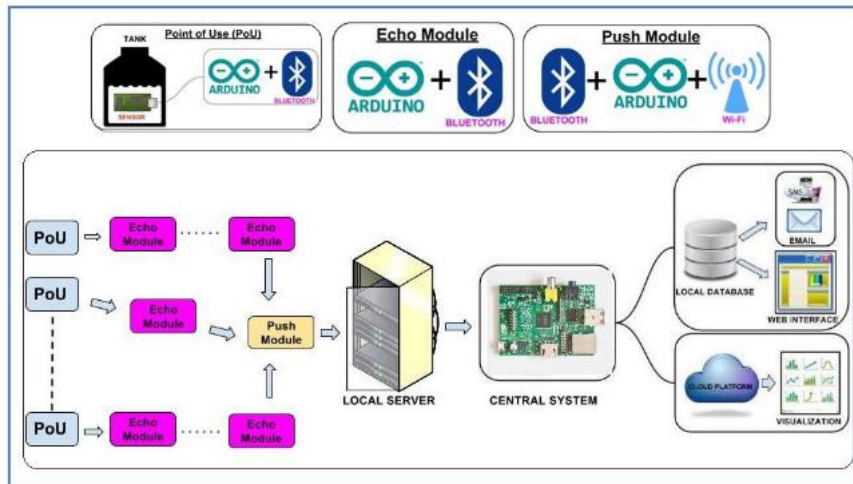
A smart water management system proposed by (Mohammed Shahanas & Bagavathi Sivakumar, 2016) looked at automating water collection, monitoring water levels and water usage analysis in a campus setting. The solution consisted of collecting water levels from tanks using sensors, transmitting the data to a centralized server using Arduino and Raspberry Pi, and visualizing the data through a web interface hosted in the cloud using Ubidots Cloud Platform. It also included an SMS and email alert system. The solution comprised four main components.

The first component of the system was Point of Use (PoU), where water level sensors were deployed. There were two types of PoUs: sumps and overhead tanks (OHT). Four sensors were to be installed in each PoU at levels 20%, 40%, 60%, and 80%. The sensors would give a **TRUE** value if water was present at the corresponding level and **FALSE** otherwise.

The second component was one Arduino board with Bluetooth Low Energy (BLE) at every PoU for data collection. The third component was the Echo Module, which acted as a hop between PoUs that were not in the range of Wi-Fi. An Arduino board with BLE could be used as the Echo Module. The number of such hops required depended on the distance between PoUs and the place with the Wi-Fi range. The receiving module, the push module (that is, the hop in the Wi-Fi range) designed as Arduino with Bluetooth in software serial and Wi-Fi in hardware serial port. This Arduino would push the data to a file in a local server.

The fourth and final component of the system was data processing and integration. A Raspberry Pi- a low-cost fully functional computer with Wi-Fi connectivity, was used as the central system. Data from the local server was fetched by the central system and then processed. The Raspberry Pi was configured to populate the data to corresponding tables for visualization,

populate the data to the cloud, trigger Email/SMS alerts when the water level went below the threshold, and trigger Emails with different reports on a daily/monthly/yearly basis.



**Figure 2.3 Architecture Diagram for the Smart Water Management System**

### Challenges

The coordination of resources across different regions and ecosystems posed a **major challenge for the implementation** of this solution. Investment and innovation in core water infrastructure are crucial in the development of efficient methods for water conservation, and smart innovations can play a vital role in addressing this complexity for society, businesses, and governments. However, national and international financial support was lacking, hindering the scaling of these innovations to residential homes, which was necessary for evaluating the social acceptability and impact of this technology. Further resources were required for analytics such as consumption forecasting and water leakage detection to make informed decisions and determine the success of the smart water management system in reducing water wastage.

### 2.3.2 A wireless household water consumption monitoring system in Europe

(Yang et al., 2017) conducted a study across four European countries to monitor domestic water consumption at the appliance level and intervene in people's water usage behaviour by utilizing Internet of things (IoT) technologies. The researchers wirelessly recorded the water consumed by each household appliance with the exact consumption time and stored the data in a central database. A decision support system deployed as a mobile application on a tablet or mobile device provided real-time water consumption awareness, practical advice for water-saving activities, and classification of water consumption behaviour for individuals. The study aimed to reduce water wastage by encouraging more conscious water usage.

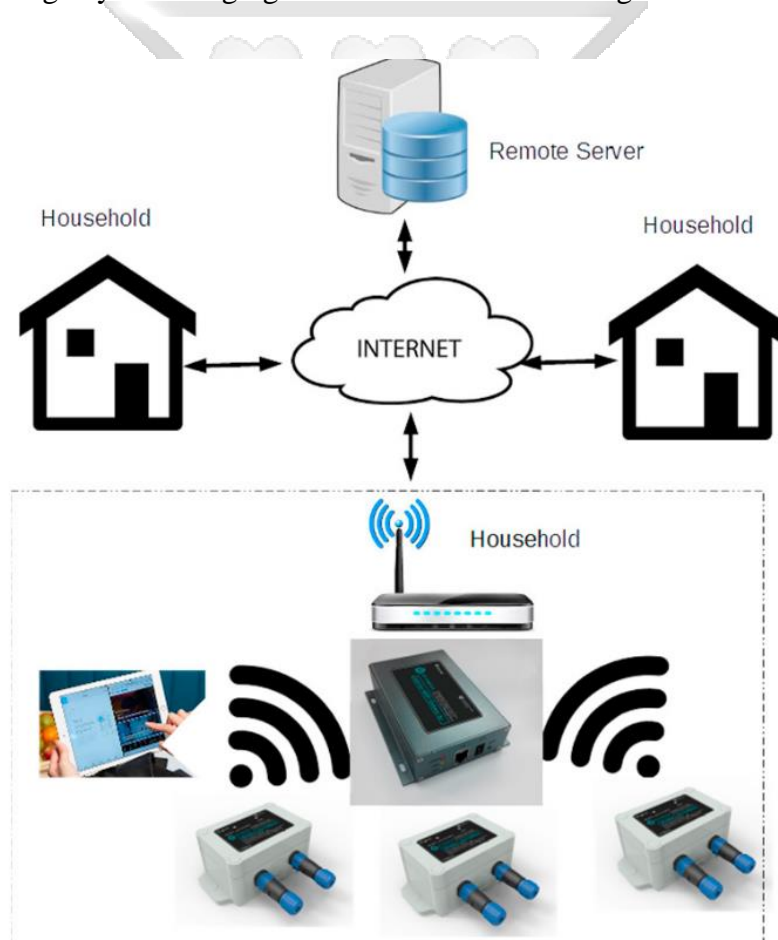


Figure 2.4 System Architecture (Yang et al., 2017)

## **Obstacles facing the solution**

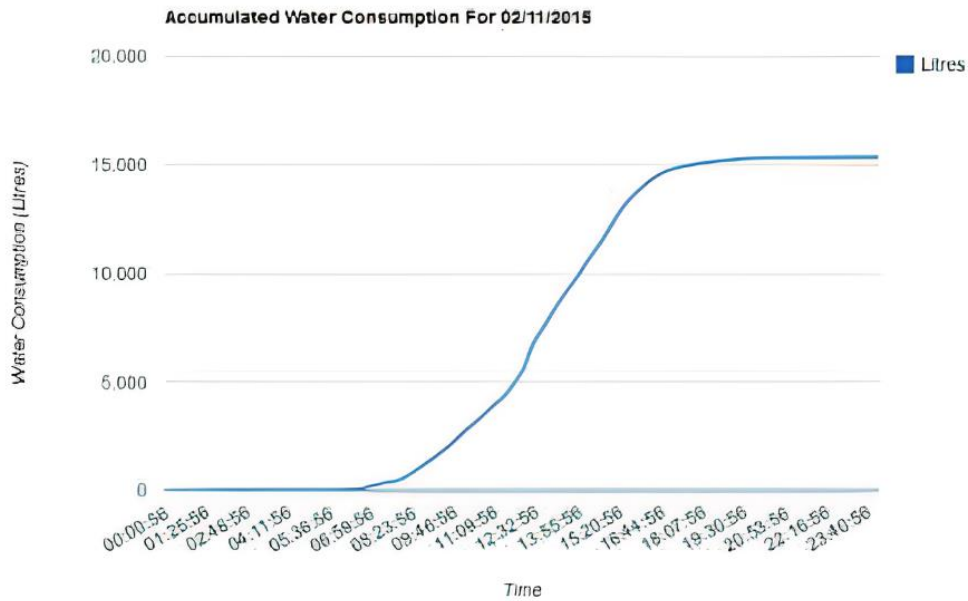
The major obstacle facing this solution was the inadequate implementation and integration with the current infrastructure. Although the solution addressed problems within the four European countries, it was limited in its ability to expand to other regions, countries or even continents, as there was no universal standard for the internetworking, control, and management of equipment, therefore considered a closed source system. End-users were left with systems that could not be maintained or updated by other experts, posing a challenge.

### **2.3.3 Smart Water Meter System for User-Centric Consumption Measurement South Africa**

Most African countries, including South Africa, use analogue water-metering systems that are read manually. This process is labour-intensive and often leads to inaccurate readings based on historical data. To address this issue, a smart water management system was implemented to provide real-time data for analysis (Mudumbe & Abu-Mahfouz, 2015). The system monitors water consumption as a whole and creates visual graphs to present the data in a readable format for the customer. A web-based monitoring application was developed for customers to view real-time and historical data on water consumption, allowing them to identify any leaks or unattended open taps in their water flow system. The smart water meter was installed in an office building with around 250 employees, where water consumption was expected to be highest during working hours.

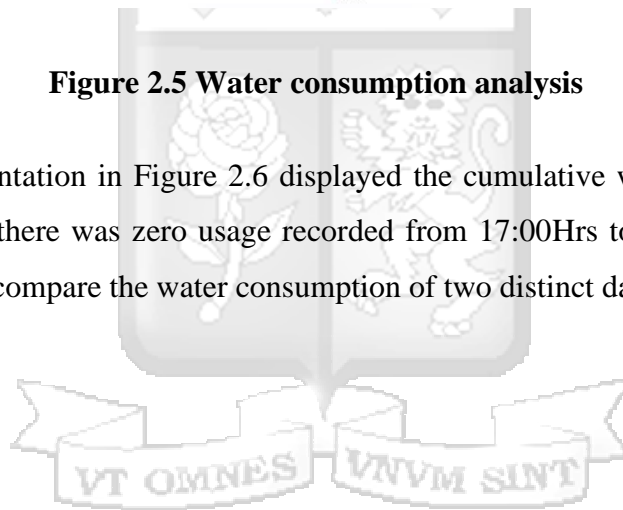
The monitoring system and web-based application were essential components of the smart water management system as they enabled users to receive real-time data and identify any changes in the system. However, the main challenge for many African countries in adopting such systems is the reliance on outdated technology and the lack of infrastructure to support the integration of smart meters with existing systems.

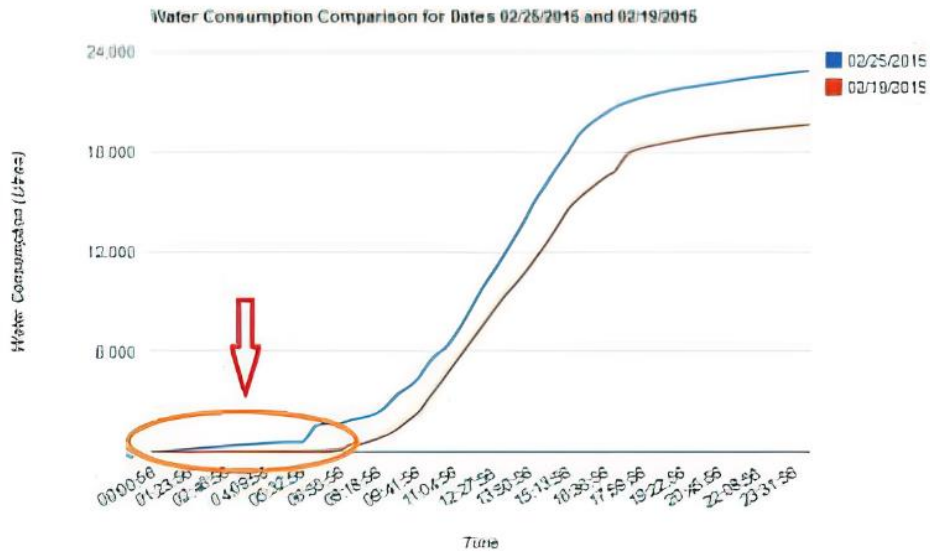
A representation of the collected data is shown the Figure 2.5.



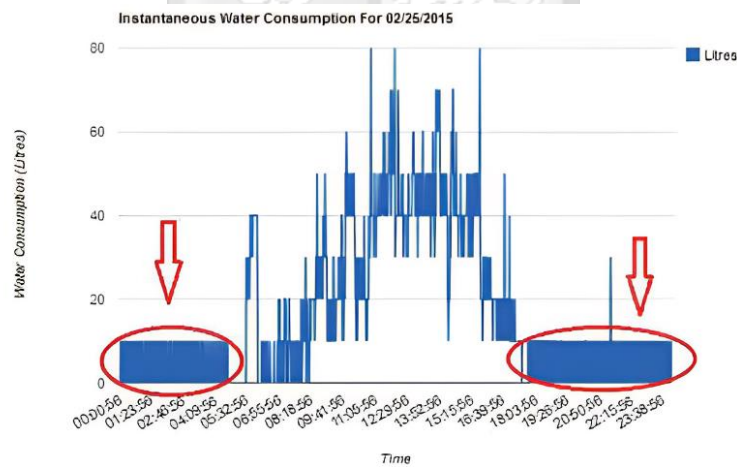
**Figure 2.5 Water consumption analysis**

The graphical representation in Figure 2.6 displayed the cumulative water usage over some time. As anticipated, there was zero usage recorded from 17:00Hrs to 7:00Hrs. The system facilitated the user to compare the water consumption of two distinct days.





**Figure 2.6 Cumulative water consumption**



**Figure 2.7 Water Consumption Comparison**

The graph depicted in Figure 2.7 illustrated an unusual pattern of water consumption during the early hours of the day when no consumption was anticipated, and a steady consumption throughout the day. Further investigation revealed a leak outside the building, but it was

fortunate that the leaked water was visible on the ground. In the absence of a monitoring system, the leak could have gone unnoticed for hours or days and could have remained unresolved for several months.

### **Major Challenge**

A significant difficulty faced by the system was keeping track of the battery charging status and interface node operation. This meant when the system was out of charge, it would go off and the users would not be aware that the monitoring system was not working. The interface node operation was also difficult to use and support of each node also posed a problem as there was no central module to manage the nodes. The system did not include a localized algorithm to detect unusual water consumption at designated areas, which prevented it from detecting specific localized leakage in real-time. There was therefore need for a user-friendly application, which was easy to manage real-time data and send alerts based on various events like leak detection and offline status of nodes.

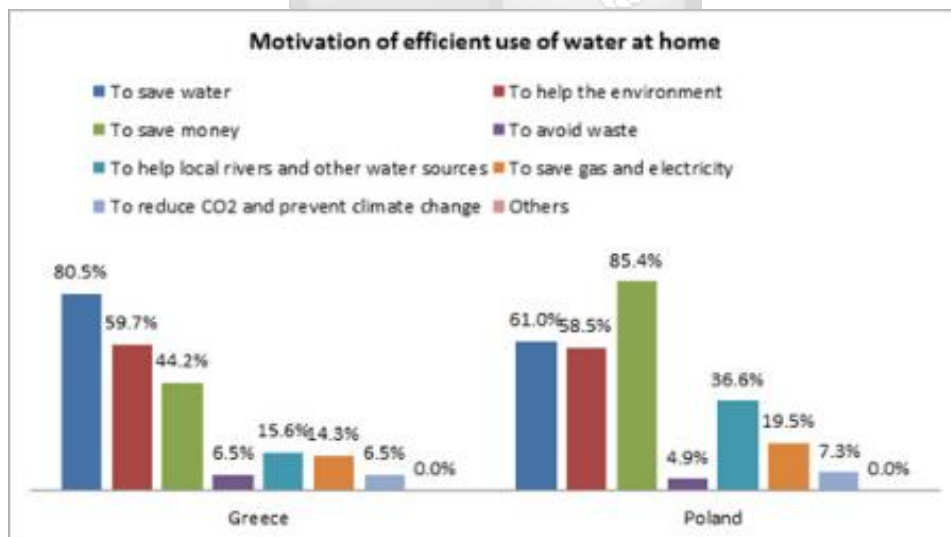
#### **2.3.4 Water Management in Athens and Warsaw**

The Integrated Support System for Efficient Water Usage and Resources Management (ISS-EWATUS) project, funded by the European Union (EU), conducted a study on household water consumption in the EU. The University of Thessaly in Greece and the Institute for Ecology of Industrial Areas in Poland distributed a survey to collect data on how water was used in respondents' homes. The survey collected information on perceived daily water consumption, motivations for using water efficiently, and attitudes towards water conservation methods. The study's goal was to determine ways in which households could be encouraged to use water efficiently and implement conservation measures.

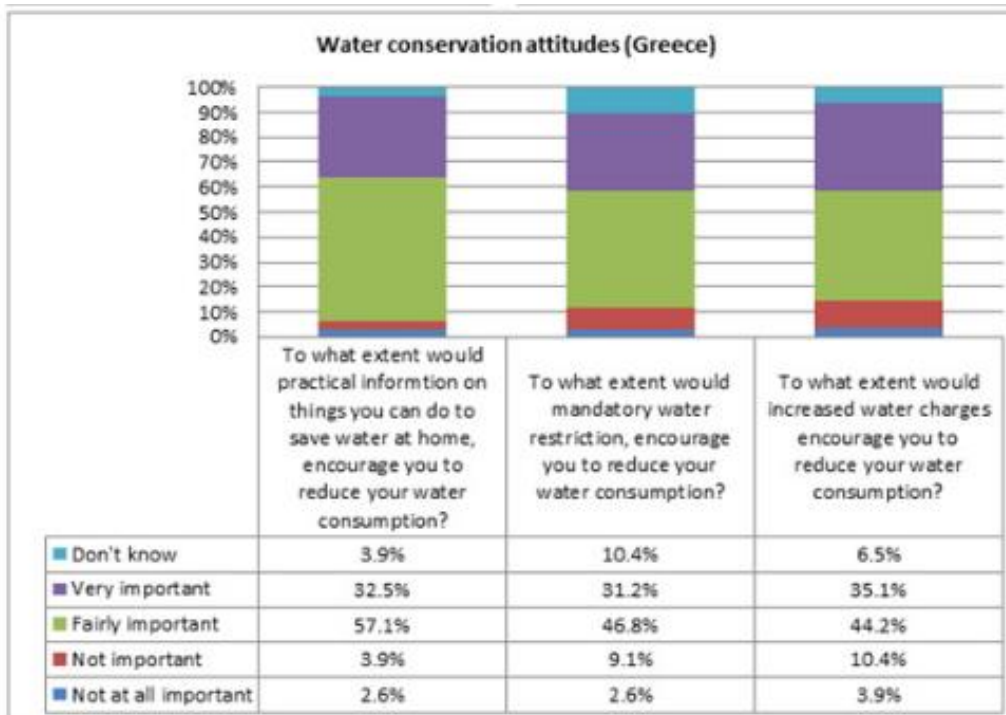
The survey data revealed that respondents had three primary motivations for using water efficiently, which were to save water, to help the environment, and to save money. The data collected was deemed useful in designing future behaviour interventions that focus on

knowledge intervention. The order in which respondents ranked these motivations differed between Greece and Poland, reflecting the countries' different water meter installation rates. Respondents in Poland, where water meters were almost universal, ranked saving money as the most widely acknowledged motivation for using water efficiently. On the other hand, most households in Greece had not installed water meters and were less likely to choose this reasoning for saving water. This study suggested that structuring water prices could directly influence household water use.

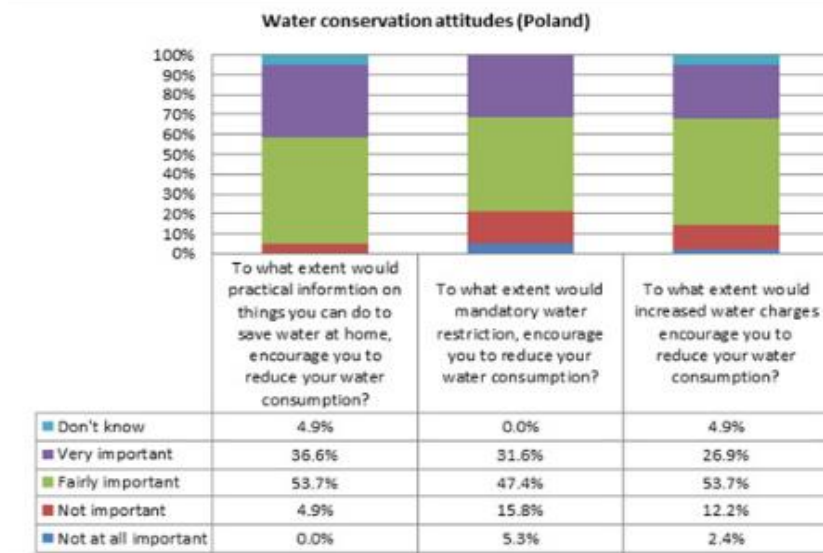
The results of the survey showed that respondents' attitudes towards water conservation methods varied. The majority of respondents were willing to take steps to conserve water, such as repairing leaks and reducing the amount of water used for cleaning. However, respondents were less likely to adopt more drastic measures such as using a bucket to collect water for flushing the toilet or showering less frequently. Respondents' attitudes towards water conservation were also seen to be influenced by factors such as their level of education, income, and the perceived effectiveness of different water conservation methods. The survey data suggested that tailored interventions aimed at specific groups of households may be more effective in promoting water conservation.



**Figure 2.8 Motivation of efficient water use in Greece and Poland**



**Figure 2.9 Water Conservation attitudes in Greece**



**Figure 2.10 Water conservation attitudes Poland**

## **Limitations to the Study**

The study had limitations in that it only provided insights into household-level water consumption behaviour and did not examine conservation practices for reducing wastage. The research concentrated on identifying the factors that motivate individuals to use water efficiently, such as saving water, helping the environment, and saving money. However, it did not delve into the various water management techniques implemented or the areas where water wastage was reduced. This limitation highlights that the identification of various water conservation measures and designs needed to manage water was not included in the study.

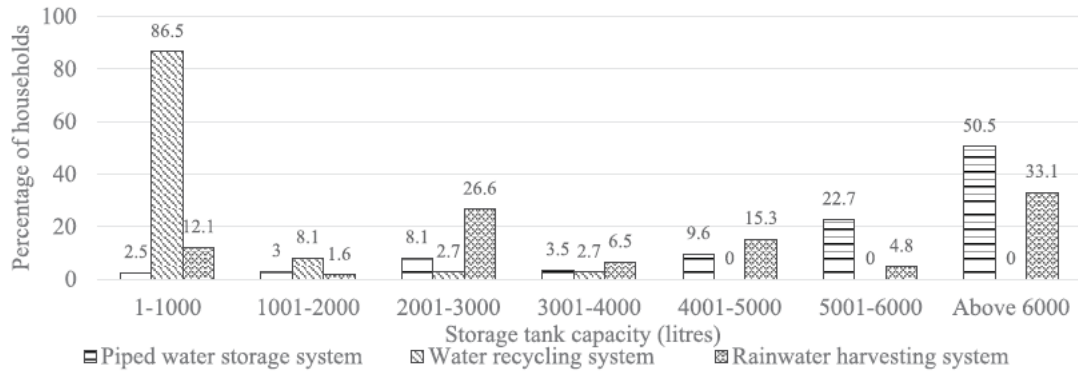
### **2.3.5 Water Management in Nairobi**

(Shikuku et al., 2022) conducted a study in Nairobi to examine the effectiveness of water conservation systems installed in two hundred households. According to the study, piped water storage, water recycling, and rainwater harvesting were found to be the three major systems that promoted the collection and reuse of more water to conserve supplies. The piped water storage system involved the use of cisterns to store water from the direct clean water supply. This stored water was used when the direct supply becomes scarce, thus ensuring a continuous supply of potable water during water shortages.

The storage tanks served as water banks that provided access to clean water for short or long-term usage when the direct piped water supply operated intermittently. The water recycling system, on the other hand, involved the use of greywater from sinks, showers, and washing machines for irrigation and flushing toilets. Lastly, the rainwater harvesting system collected rainwater from rooftops and other surfaces for later use. The study found that these systems provided a viable solution to the water scarcity problem in Nairobi.

The research highlighted the importance of implementing effective water conservation systems to promote sustainable water use in urban areas. The findings suggested that these systems had the potential to reduce water wastage and ensure a reliable supply of potable water during

periods of water scarcity. By promoting the adoption of these systems, water utilities and policymakers could work towards mitigating the adverse effects of climate change on water resources and ensure that urban residents have access to safe and clean water.



**Figure 2.11 Distribution of storage capacity for water conservation systems**

The researchers utilized the benefit-cost ratio as a means of conducting a cost-benefit analysis of the three water conservation systems. The purpose of this analysis was to assess the feasibility of implementing these systems based on their associated costs and benefits. Figure 2.12 and Figure 2.13 show the household benefits that were realized from the conservation systems implemented.

Showing household function benefits of water from the water conservation systems.

Water conservation system	System's water function in household	Percentage of water function in household	Total percentage of household water functions	A percentage of household monthly water expenditure
Piped water storage system benefit	cooking and drinking	18.78	100	100
	dish-washer	1.75		
	bathing	22.05		
	clothes washing	25.54		
	toilet flushing	31.88		
Rainwater harvesting system benefit	dish-washer	1.75	81.22	81.22
	bathing	22.05		
	clothes washing	25.54		
	toilet flushing	31.88		
Water recycling system benefit	toilet flushing	31.88	31.88	31.88

**Figure 2.12 Function benefits**

Summary of benefit, cost, and benefit–cost ratio of water conservation systems.

Water system	Benefit	Cost	BCR	Implication
Piped water storage system	21,401,650.50	7,637,106.64	<b>2.80</b>	Viable with higher economic benefit
Water recycling system	15,317,916.62	17,665,008.58	<b>0.87</b>	Not economically viable
Rainwater harvesting system	20,620,280.44	10,146,229.93	<b>2.03</b>	Viable with economic benefit

**Figure 2.13 Benefit-cost ratio of water conservation systems**

The researchers of the study concluded that the installation of piped water storage systems in household buildings should be encouraged, followed by rainwater harvesting systems. These two systems would guarantee a sufficient supply of decent quality water to households at an economically viable cost, thereby promoting water conservation in households and improving access to safe water in Nairobi County. Moreover, the economic benefits of advanced technologies in water recycling systems should be promoted, which can improve their economic viability, according to Shikuku et al. (2022).

### **2.3.6 IoT-Based Water Leakage Detection Using Smart Objects for Smart City**

A study conducted by (Marathe et al., 2021) highlighted the need for a reliable and efficient solution using IoT and smart objects to detect leakages, approximate their locations, and alert the water management team promptly. The proposed system aimed to overcome the drawbacks of existing methods by using smart objects, specifically NodeMCU and water flow sensors, for water leakage detection. The system architecture involved connecting water flow sensors to the pipelines and using NodeMCU as a Wi-Fi-enabled microcontroller to measure and transmit flow rate data to ThingSpeak-an IoT analytics service. The system compared flow rate values from different sensors and detected leakages based on predefined threshold values. The leakage location was approximated and sent as an alert message to the water management team using Google Maps API, Pushbullet, and PushingBox.

The system provided a graphical view of leakage locations on a webpage using Google Maps integration. Additionally, alert notifications were sent to registered Android devices using Pushbullet.

### **Gaps and challenges of the solution**

The use of ThinkSpeak application as the application of choice for water detection requires integration with additional third-party applications such as PushBullet and PushingBox to facilitate alert creation and push notifications. The monitoring of this application was also noted to be an online application and not a mobile application. This creates additional overhead for the user, therefore making it less user-friendly. For tracking household water usage and detecting leakage, an all-in-one application such as the Blynk IoT application would be the preferred option. Blynk application offers a cloud-based fully integrated suite of IoT software with a user-friendly interface, allowing for easy dashboard creation, alert generation using an events module and real-time water usage analysis.

#### **2.3.7 Smart Residential Water Leak and Overuse Detection System**

(Ismail et al., 2022) from Abu Dhabi University and Khalifa University in the United Arab Emirates conducted a study to develop a system that could detect water leaks and overuse in residential properties using machine learning. The study examined the issue of residential water leakage and consumption, which often goes unnoticed for a long time, leading to significant water waste. A leakage detection model that utilizes sensor technologies and machine learning algorithms to detect leaks early and minimize water wastage was proposed. The study used a physical prototype to test the proposed model's effectiveness.

The tools used in the study included IoT (Internet of Things) devices such as water flow sensors, water pressure sensors, water level sensors, and temperature sensors. These sensors were integrated into a microcontroller, Raspberry Pi 4 Model B+, which collected sensor readings and performed calculations. The data collected by the sensors were stored in a cloud-

based database. The proposed system utilized machine learning algorithms for predictive modelling and anomaly detection.

An offline module of the framework simulated various water usage scenarios, including leakage, normal usage, and overuse, to generate a ground truth dataset for water consumption. Feature selection and predictive modeling were performed to identify the most relevant features and develop a predictive model for water leakage detection. An online module on the other hand represented a real-life water supply and distribution system in residential properties. It included sensors for monitoring water level, water flow, pressure, and temperature. The microcontroller collected sensor readings and sent the data to a web server, which stored the data in the cloud-based database. The predictive model imported from the offline module was used to detect possible leaks and send alerts to the user through an application dashboard.

The experimental results showed that the proposed model achieved an overall accuracy of 87% in detecting leakage and overuse. The recall, which measures the ability to detect positive cases, was 83%, indicating that the system detected most instances of leaks.

### **Challenges with the solution**

Training an accurate predictive model with high precision to detect water leakage cases and differentiate them from other modes of water consumption was extremely challenging due to the minority representation of leakage instances which accounted for only 4% of the samples. Consequently, the model faced difficulties in achieving high precision, which was crucial for correctly identifying true leakage cases while minimizing false positives. Since the majority of the dataset consisted of non-leakage cases, the model primarily focused on accurately predicting those, potentially leading to missed leakage instances or incorrect classification of rare leakage cases as non-leakage. This accuracy may have been achieved by narrowing down to specific faucets and having a wider representation of leakage instances to achieve higher leakage precision.

## **2.4 Models for water usage management**

There are various models and tools that help in managing water consumption and water resources.

### **2.4.1 Descriptive models**

(Cominola et al. 2015) suggest that descriptive models are used to analyse the water consumption behaviour of water users. These models can be used to identify patterns in aggregate consumption or to create user profiles based on individual users' behaviour. Descriptive models can be constructed using historical data to identify trends and create consumption profiles. This approach can be used to identify areas where conservation efforts can be focused. For example, if gardening is the dominant end-use, conservation efforts could be focused on restricting irrigation practices.

### **2.4.2 Predictive models**

The primary goal of predictive models is to estimate individual or household water demand, as stated by (Cominola et al., 2015). However, the short-term forecasting of water demand based on time series analysis, which is often used in these models, has limited efficacy in designing and implementing water demand management strategies. This is because it does not consider the socio-psychographic factors that influence an individual's water consumption or response to various water demand management strategies. An alternative approach involves two sub-steps, which are multivariate analysis and behavioural modeling.

The first sub-step, multivariate analysis, is critical to building predictive models of urban water demand variability in space and time. Data mining techniques, such as correlation analysis, are often used to identify the most relevant drivers of water consumption. These drivers are then analyzed alongside water consumption data to create the most effective predictive model. This approach is also known as inductive modeling, as it uses empirical data to identify the most critical drivers of water demand.

The alternative to data-driven modeling is deductive modeling. It involves constructing models based on empirical or theoretical causality. This approach considers domains such as economic-driven, geospatial, and psychographic-driven studies. Economic-driven studies analyze the correlation between water consumption and economic drivers such as water tariffs and water price elasticity. Geospatial studies assess the correlation between hydro-climatic variables, seasonality, and water consumption. Psychographic-driven studies infer the influence of users' personal attributes, including income, family composition, lifestyle, and household physical characteristics such as the number of rooms and the presence of a garden.

In summary, predictive models aim to estimate household water demand. The efficacy of these models relies on a multivariate analysis of the most relevant drivers of water consumption. Deductive and data-driven approaches are used in identifying these drivers. While the data-driven approach uses empirical data to identify critical drivers, the deductive approach considers theoretical causality in constructing models based on domains such as economic-driven, geospatial, and psychographic-driven studies.

### **2.4.3 Artificial Neural Networks**

Artificial Neural Networks (ANNs) are a type of machine learning algorithm that imitates the structure and function of the human brain. ANNs comprise interconnected layers of nodes, also called neurons. Each node receives input from other nodes and generates an output based on that input. TensorFlow, a widely used open-source library developed by Google for Artificial Intelligence applications, is an example of an ANN.

In a study conducted by (Hahsler et al., 2021), TensorFlow was employed to create a deep learning model that predicts residential water consumption based on factors such as household size, income, and weather conditions. The neural network was trained to predict water usage patterns and identify the factors that contribute to excessive water consumption in households. (Shuang & Zhao, 2021).

#### 2.4.4 ARIMA Based Framework

The Autoregressive Integrated Moving Average (ARIMA) model is utilized in statistics and econometrics to assess events that occur over a specific period. It is used to comprehend historical data or make projections regarding future data in a series, as per the National Institute of Standards and Technology. This model is extensively applied in data analysis to support future planning and predictions.

To anticipate the trend of daily water consumption data, the ARIMA model can be utilized. In an ARIMA ( $p, d, q$ ) model, AR represents autoregressive,  $p$  signifies the number of regression terms, MA refers to moving average,  $q$  represents the number of moving average terms, and  $d$  denotes the time difference required to make the data a stationary series, as per (Du et al. 2020). The flow of Data forecast is shown in Table 2.1.

**Table 2.1 Flow of Data forecast based on ARIMA**

1	<b>Stability treatment: The training set of original sequence is tested for stationarity. If the data sequence is non-stationary, the difference operation is carried out to determine the difference order <math>d</math>, to obtain the stationary state.</b>
2	<b>Model selection: The parameters <math>p</math> and <math>q</math> of the ARIMA model are determined. According to the BIC criterion, the <math>p</math> and <math>q</math> values, which minimize the BIC value, are selected.</b>
3	<b>Model test: Whether the residual data sequence after fitting by the selected model is white noise. If the residual is white noise, the model is valid.</b>
4	<b>Forecast future data: The valid ARIMA (<math>p,d,q</math>) model is used to predict the data in the next few days.</b>

#### 2.5 Algorithms for Water Management

There are various algorithms used in household water management and these are dependent on the goals of the household.

### **2.5.1 Weather-Based Algorithms**

Weather-based algorithms focus on managing water for agricultural use. They use weather data to inform irrigation scheduling and improve the efficiency of irrigation systems. They do this by considering weather conditions and other environmental factors using sensors and transmitters, hence can reduce water waste and increase crop yield. Weather-based algorithms are used as well to optimize irrigation scheduling, ensuring that crops receive the appropriate amount of water without waste, ultimately reducing water usage and improve crop yield (Zhang et al., 2017)

### **2.5.2 Demand-Based Algorithms**

Demand-based algorithms predict water usage patterns and optimize supply in real time. These algorithms use machine learning and data-driven approaches to improve system performance and reduce costs. These algorithms can be used to forecast the water demand and optimize the water supply to meet the demand. This helps to minimize water waste, reduce costs, and improve the overall efficiency of the water system at the home (Lu et al., 2020).

### **2.5.3 Network-Level Algorithms**

Network-level algorithms are used to optimize the performance of water distribution networks by reducing water loss and improving efficiency. They can also identify and address problems such as leaks, pressure drops, and water quality issues. They are largely used to improve the overall efficiency of water distribution systems, reducing water loss and the associated costs. When problems such as leaks and pressure drops are detected and addressed, these algorithms also help to improve water quality and reduce the risk of infrastructure damage (Jin et al., 2019)

### **2.5.4 Leak-Detection Algorithms**

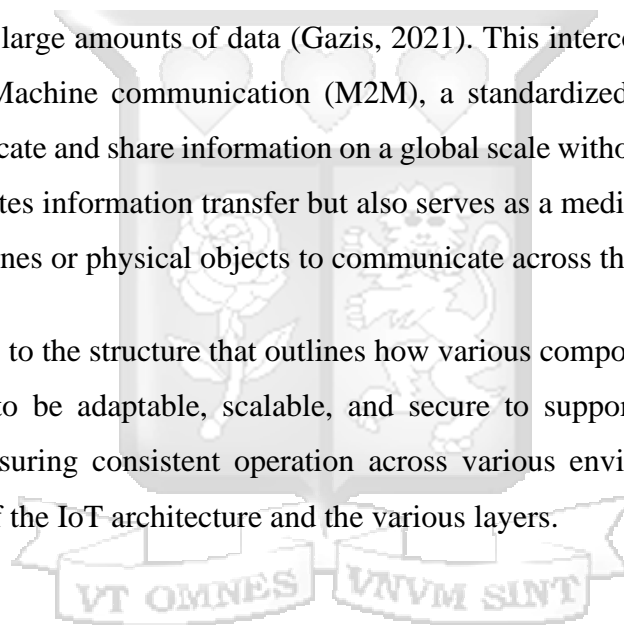
Leak detection algorithms use real-time data to identify leaks and other sources of water loss in distribution systems. These algorithms rely on data-driven approaches and machine learning

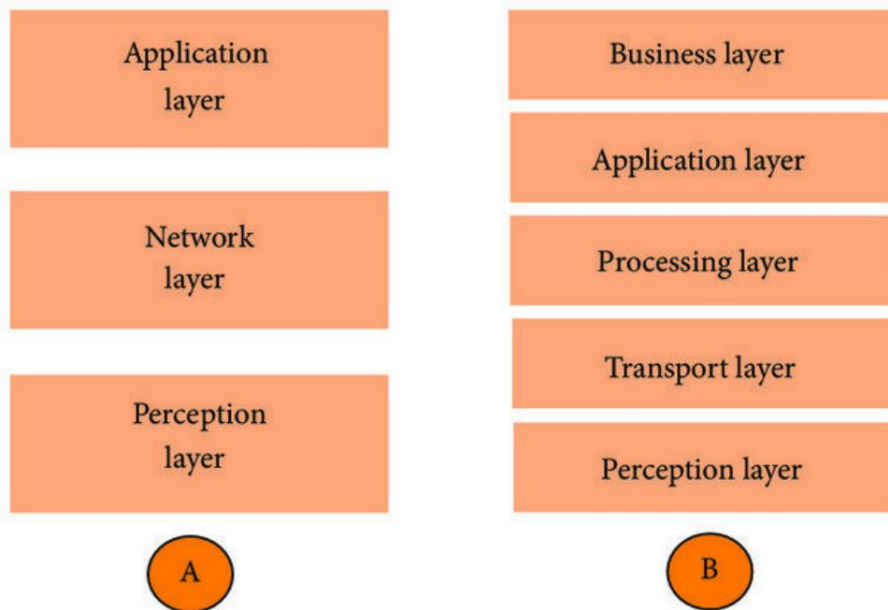
to analyse pressure and flow within the distribution system, to identify and address problems in real-time. These algorithms can be used to identify leaks in real-time, reducing water waste and preventing damage to water infrastructure. When leaks are detected early, water utilities can save significant amounts of water and reduce the costs associated with water loss (Zhou et al., 2020).

## 2.6 Internet of Things (IoT) and IoT Architecture

IoT has emerged as a pivotal technology in our daily lives, enabling the interaction between humans and smart devices. It involves a vast network of computer devices, including sensors, that rapidly exchange large amounts of data (Gazis, 2021). This interconnectivity is achieved through Machine-to-Machine communication (M2M), a standardized approach for various machines to communicate and share information on a global scale without human intervention. M2M not only facilitates information transfer but also serves as a mediator, providing an end-to-end layer for machines or physical objects to communicate across the network.

IoT architecture refers to the structure that outlines how various components of an IoT system and its design aims to be adaptable, scalable, and secure to support diverse devices and applications while ensuring consistent operation across various environments. Figure 2.14 gives an illustration of the IoT architecture and the various layers.





**Figure 2.14(Sethi & Sarangi, 2017) IOT architecture**

The perception layer in an IoT system architecture comprises various components like sensors and actuators that collect data and execute tasks. The transport layer facilitates the transfer of sensor data between the perception layer and the processing layer using various network options such as wireless, Local Area Network, Bluetooth, Radio waves and Near Field Communication in both directions. The middleware layer, commonly referred to as the processing layer, is responsible for storing, analysing, and processing vast volumes of data received from the transport layer. It can manage and offer an array of services to the lower layers. Various technologies, including databases, cloud computing, and big data processing modules, are utilized by the processing layer. The business layer oversees the complete IoT system, covering applications, business and profit models, and safeguarding users' privacy(Sethi & Sarangi, 2017).

## **2.6.1 Wireless Technologies in Internet of Things**

There are various wireless communication technologies used in IoT and this section gives a comparative analysis of the commonly used ones and the preferred option chosen for the study (Durand et al., 2019)

### **2.6.1.1 General Packet Radio Service (GPRS)**

GPRS is a wireless communication standard that enables the transmission of data over a cellular network. It is commonly used for applications that require low-to-medium data rates. GPRS is based on the GSM (Global System for Mobile Communication) cellular network and allows for the transfer of small packets of data between devices. However, it has relatively slow data transfer rates and may be expensive for large-scale data transfer. Devices compatible with the GSM network, such as smartphones or modems with a SIM card, are required to utilize GPRS.

### **2.6.1.2 Sigfox**

Sigfox is a low-power, long-range wireless communication technology that operates on unlicensed radio frequencies. It is designed for IoT devices located in remote or hard-to-reach locations. Sigfox can transmit data over several kilometres without the need for repeaters, making it suitable for applications requiring long-range coverage. However, it has relatively low data transfer rates and a fixed payload size of 12 bytes per message. To utilize Sigfox, a device must be Sigfox-enabled and have access to the Sigfox network.

### **2.6.1.3 LoRaWAN**

LoRaWAN is a long-range, low-power wireless communication technology that operates on unlicensed radio frequencies. It offers extensive coverage, especially in outdoor environments, and can transmit data over several kilometres without the need for repeaters or additional infrastructure. LoRaWAN provides flexibility in payload size, supporting small to moderate

data transmission. To utilize LoRaWAN, a device must be LoRaWAN-enabled, and one needs a LoRaWAN gateway which acts as a bridge between the LoRaWAN network and the internet.

#### **2.6.1.4 Wi-Fi**

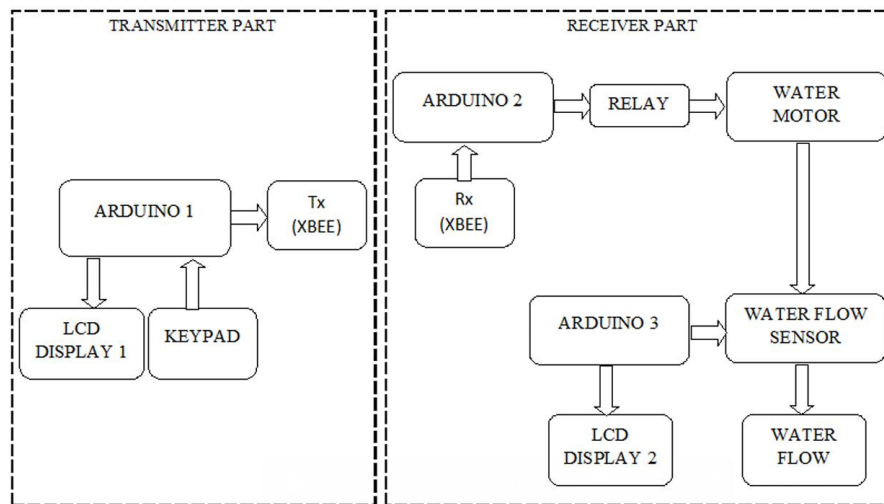
Wi-Fi is a wireless communication technology that uses radio waves to transmit data over short distances. It is widely available in most households and public spaces, making it a convenient and user-friendly wireless technology for IoT applications. One of the advantages of Wi-Fi is its high data transfer rates, which are useful for transmitting large amounts of data quickly and efficiently. To utilize Wi-Fi, a device must be Wi-Fi-enabled and have access to a Wi-Fi network.

Wi-Fi was deemed more suitable for the prototype developed due to its wide availability in households and its interoperability features which made it convenient in integrating all the IoT devices used in the prototype. The main focus was to ensure that data was uploaded in real-time to a cloud-based server, hence, to achieve this functionality existing Wi-Fi routers found in the households were deemed to be the most cost-effective and convenient.

### **2.7 Smart water management and system information flow**

A smart water management system is defined as a technology that is used to monitor and control the usage of water in a household. It uses a smart water sensor, which is a device that is capable of detecting the flow of water through a pipe or faucet (Ramos et al., 2019). This sensor is connected to a microcontroller, which is a small computer that can communicate with other devices. The microcontroller collects data from the sensor and sends it to a central server for processing. With the help of algorithms, the server can analyze the data and determine if there is any wastage. An illustration showing an architectural diagram of a smart water

management system from the transmitter to the receiver part is shown in Figure 2.15. It illustrates in detail the process by which the sensors and microcontrollers communicate.



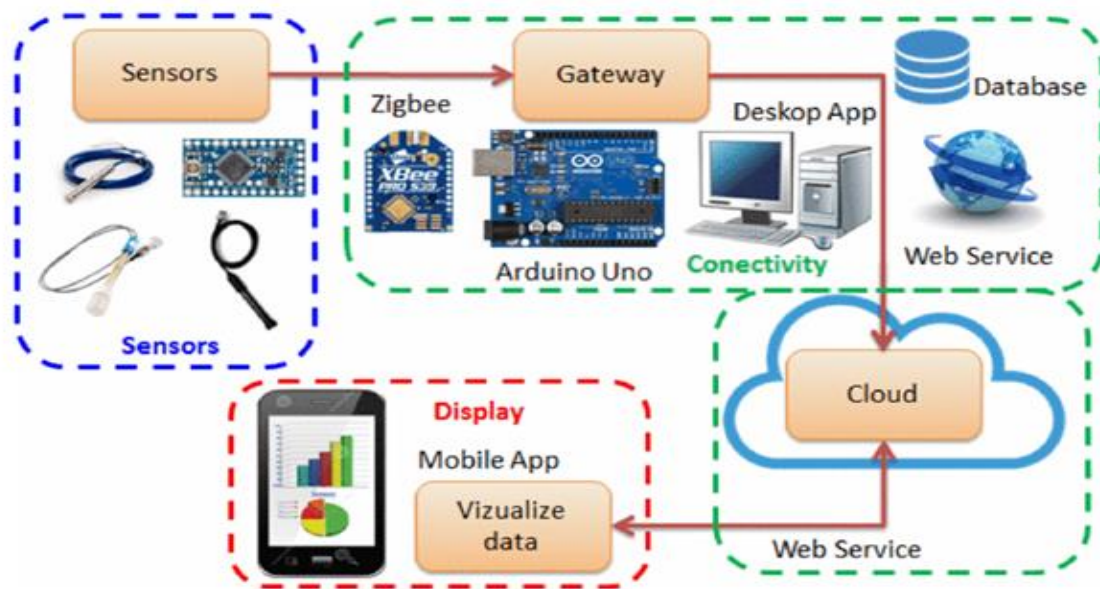
**Figure 2.15(“Smart Water Flow Control and Monitoring System,” 2018)**

Arduino 1, Arduino 2, Arduino 3 are the microprocessors used.

XBee modules are a type of Radio Frequency and cellular modems that provide flexibility for Internet of Things (IoT) developers. These modules are available in three programmable form factors and support a range of popular wireless protocols. The XBee family also includes IoT gateways and management tools that allow for the connection, monitoring, and management of the XBee network. This makes it easier for developers to create IoT applications and manage the network effectively (*Explore the Digi XBee Ecosystem*, n.d.)

The Smart Water Flow Control and Monitoring System is divided into two parts: the transmitter and receiver sections. The input to the system is given through a keypad, which displays the quantity of water 'q' to be discharged and the time 't' to complete the task on the LCD screen connected to Arduino 1. The data is transmitted wirelessly by the transmitter XBee (Tx XBee), and it is received by the receiver XBee (Rx XBee). The data is then given to Arduino 2, which is connected to the water motor through Relay to reduce power consumption. The water motor

pipe is inserted into the water flow sensor, which is interfaced with Arduino 3. The required amount of water is then made to flow through the pipe according to the code. The flow rate is displayed on the LCD screen 2. This system allows for efficient monitoring and control of water flow at home through an online mobile application's graphical user interface (GUI), making the process more convenient for homeowners (Smart Water Flow Control and Monitoring System, 2018).



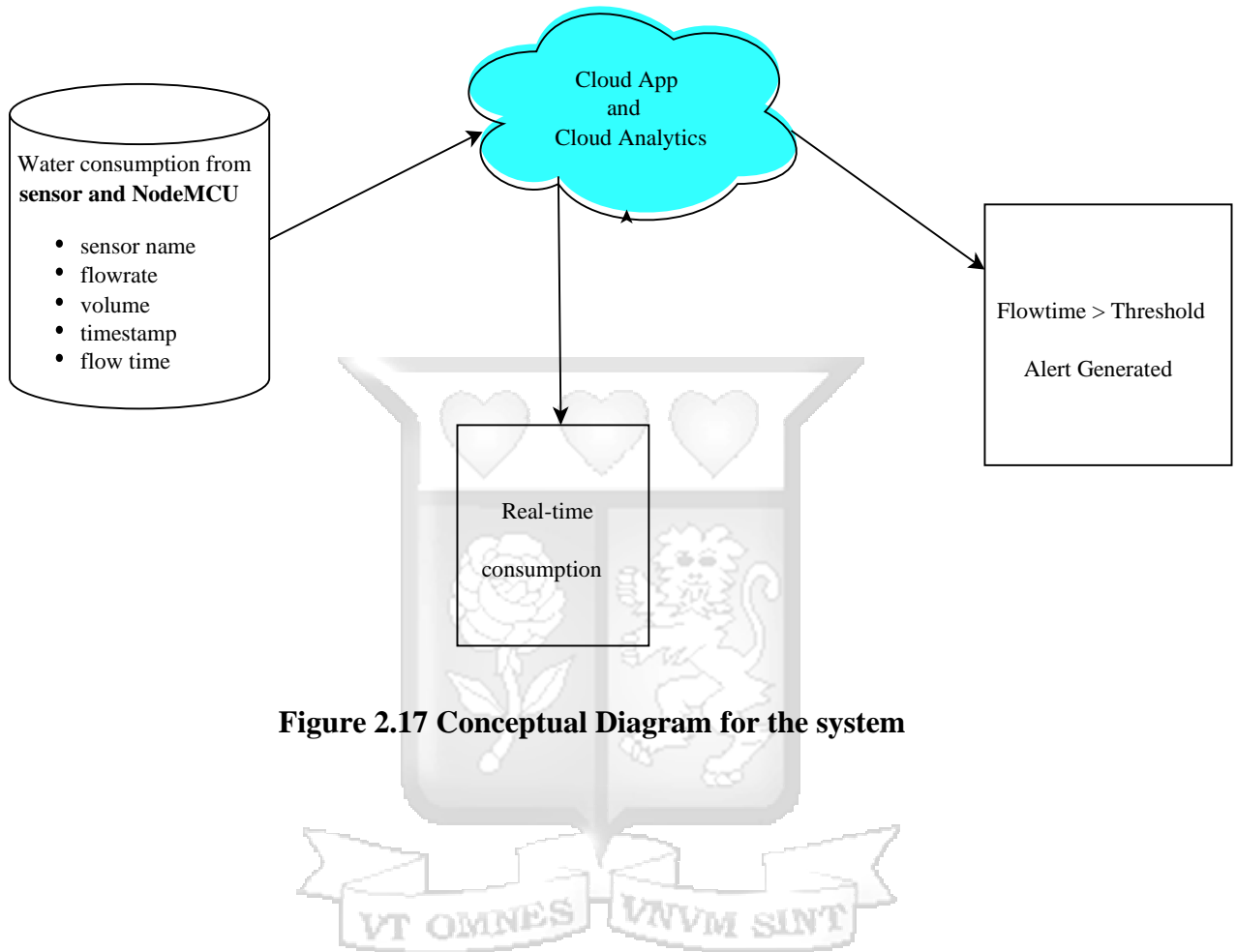
**Figure 2.16 Information Flow (Kamaruidzaman & Nazahiyah Rahmat, 2020)**

Figure 2.16 shows the information flow within the IoT water management system and the interoperability of all the components.

## 2.8 Conceptual Framework

The prototype was developed using the conceptual framework depicted in Figure 2.17. The framework involves collecting water consumption data, sending it to a cloud-based engine and generating an alert when excessive usage is detected. The cloud-based application and storage solution was incorporated to ensure the availability of the system as well as long-term data

storage and data analysis. This will aid in the development of improved water management strategies.



**Figure 2.17 Conceptual Diagram for the system**

## **Chapter 3 : Research Methodology**

### **3.1 Introduction**

In this research, a smart water management prototype was developed to monitor real-time water usage data from multiple faucets, analyse it, and send usage and wastage alerts to the user. Data was acquired using a water flow sensor directly connected to a faucet. The goal was to provide users with their water usage information from various water fittings in their homes and alert them of potential leaks to reduce unnecessary water waste. This chapter outlines the research methodology that was used to conduct the study.

### **3.2 System Development Methodology**

The development methodology that was chosen involved an iterative approach to data collection and analysis, with a focus on continuous improvement of the research problem. The process consisted of a conceptual design, system architecture, system prototyping, and system development. This approach was chosen because it was expected to reduce the risk of failure and accommodate changes in requirements, as well as allow users to adapt to the system in smaller, incremental steps.

According to research done by (Alshamrani & Bahattab, 2015) on the iterative model, it was found that it involved gradually adding functionality to a partial implementation of a total system. Each subsequent release would include a new function until all designed functionalities were implemented. This enabled users to adjust to the system in smaller, incremental steps rather than implementing major new changes at once.

Figures 3.1 and 3.2 provide a detailed overview of the iteration method and the steps involved in the model. The first step was planning, followed by requirements gathering in the second step, design and analysis in the third step, implementation and testing in the fourth step, and evaluation and review in the fifth step. These steps went through several iterations until all functionalities were completed.



**Figure 3.1 Iteration method**



**Figure 3.2 Iteration Process (Srivastava et al., 2017)**

### **3.3 Research Design**

The research employed an empirical research methodology, which involved planned observations to generate data in a systematic and thoughtful manner, as defined by (Patten, 2016). This methodology entailed five key steps: deciding what to observe, selecting whom to observe, determining how to observe, establishing when to observe, and planning how to analyse and interpret the resulting data. These five steps were carefully addressed throughout the research project.

As stated by (Patten, 2016), empirical research is a deliberate process that entails making well-planned observations. “The researcher must carefully plan the observations to ensure they are systematic and well-considered, which helps to ensure the accuracy and reliability of the data”. In this research, the five steps outlined by (Patten, 2016) were followed to achieve these goals.

#### **3.3.1 Location of the study**

The study was conducted in Nairobi County, Lang’ata constituency. The choice of this location was influenced by factors such as accessibility to the households, availability of households with piped water, and the prevalence of water management issues in the area.

The target areas for the study were the kitchen and bathroom areas within the households. These areas were selected because they are typically the main areas where water is used in households, and thus have the greatest potential for water wastage or leakage. The bathroom and kitchen faucets were fitted with water flow sensors connected to a programmed microcontroller, managed by both an online and mobile app. By focusing on these areas, the study was able to generate data and send alerts that could be used to inform the development of more effective water management systems and practices.

### **3.3.2 Sample population**

This was done in five households. The sample selection was based on the number of households that granted access to the researcher to install the setup of the water management devices and allow for real-time monitoring of their water usage. Five households were deemed sufficient for this study, as they provided a representative sample of different household sizes, water consumption patterns, and usage habits, ensuring that data could be analysed and interpreted effectively within the constraints of the research project.

### **3.3.3 Data collection procedure**

A smart water sensor connected to a microcontroller was used to collect household data which included the flow rate, volume, and timestamp. The water flow sensors connected directly to the kitchen and bathroom faucets, measured the flow rate of water passing through it, and the microcontroller processed this data to calculate the total volume of water consumed whenever water flow was detected, from the time it started flowing until it stopped flowing. The timestamp was also recorded to provide context for when the water was used.

The water flow sensor data was uploaded to the cloud as the microcontroller connected to a Wi-Fi module allowed it to communicate with the internet. This data was sent as a stream of information that included the flow rate, volume, and timestamp for each reading. A snippet of the code used to achieve this is captured in Figure 3.3

```
const int flowPin = 2; // Pin connected to flow sensor
volatile int flowCount = 0;
float calibrationFactor = 6.6; // Calibration factor for flow sensor

BlynkTimer timer;

void sendSensorReadings()
{
  // Calculate flow rate and volume
  float flowRate = (flowCount / calibrationFactor) * 60;
  float volume = (flowCount / calibrationFactor);

  // Get current time
  String timeStamp = String(millis());

  // Send data to Blynk cloud
  Blynk.virtualWrite(V1, flowRate);
  Blynk.virtualWrite(V2, volume);
  Blynk.virtualWrite(V3, timeStamp);

  // Reset flow count
  flowCount = 0;
}

void flowInterrupt()
{
```

**Figure 3.3 Sample code for data collection and upload**

Figure 3.4 shows a display from the serial monitor as data is being uploaded to the cloud application.

```
07:30:13.605 -> Flow rate: 1L/min      Output Liquid Quantity: 2425L
07:30:14.608 -> Flow rate: 1L/min      Output Liquid Quantity: 2447L
07:30:15.625 -> Flow rate: 1L/min      Output Liquid Quantity: 2467L
07:30:16.621 -> Flow rate: 1L/min      Output Liquid Quantity: 2487L
07:30:17.619 -> Flow rate: 1L/min      Output Liquid Quantity: 2507L
07:30:18.619 -> Flow rate: 1L/min      Output Liquid Quantity: 2527L
07:30:19.597 -> Flow rate: 1L/min      Output Liquid Quantity: 2544L
07:30:20.612 -> Flow rate: 1L/min      Output Liquid Quantity: 2564L
07:30:21.612 -> Flow rate: 1L/min      Output Liquid Quantity: 2584L
07:30:22.612 -> Flow rate: 1L/min      Output Liquid Quantity: 2604L
07:30:23.633 -> Flow rate: 1L/min      Output Liquid Quantity: 2621L
07:30:24.623 -> Flow rate: 1L/min      Output Liquid Quantity: 2638L
```

**Figure 3.4 Display on the serial monitor showing data collection**

This code used an interrupt to count the number of pulses generated by the water flow sensor and calculated the flow rate based on a conversion factor of 6.6.

### 3.3.4 Data Analysis

The data collected during the study was analysed right from the point of collection. The system recorded and validated the water usage data before storing it. As water flow was not continuous but instead in batches, whenever water flow was detected, the system recorded the data and validated the reading by checking if the value was incremental to the previously recorded usage.

The flow rate, volume and time of flow were used to generate alerts based on the different thresholds that had been set for the bathroom and kitchen. The case for the bathroom used the **volume of the cistern as the threshold**. Water volume was measured when the cistern was refilled with water just after flushing a toilet. If the volume measured by the water flow sensor exceeded the cistern volume then it indicated a potential leakage that needed to be checked. An alert would be sent to the user of the system to notify them of this volume difference. The kitchen on the other hand used the amount of time water was left flowing as the threshold, and this was set at 4 minutes of continuous flow from the kitchen faucet. The 4minute continuous flow was an observed manual threshold.

To analyse the water usage patterns and wastage in households, the data collected from the Blynk cloud app was exported in CSV format and analysed. The analysed data included water usage and water wastage data, which covered the amount of water used from the installed water sensors in the bathroom and kitchen, as well as the time and duration that each water appliance was running. Based on the set threshold, the system was able to detect when the usage was above the norm and highlight the same.

The techniques used to derive insights from the data were mean, moving average, and time series analysis. Figure 3.5 shows the data collected over a 7-day period. From the line chart, a

trend had started forming, indicating that the toilet was consuming more water than the kitchen area.

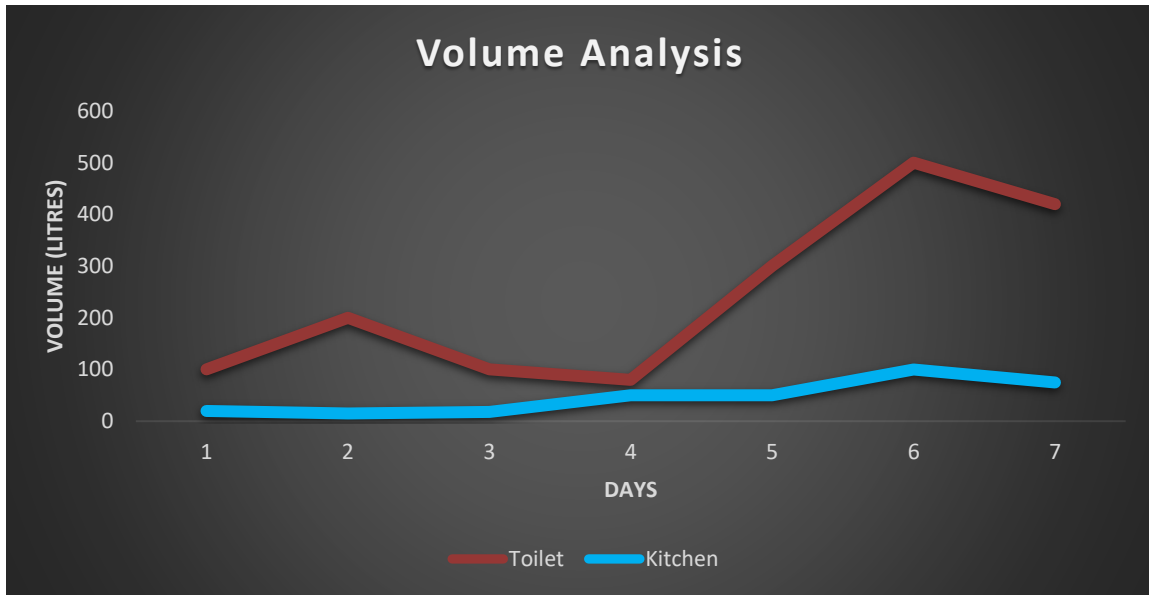


Figure 3.5 Weekly volume analysis

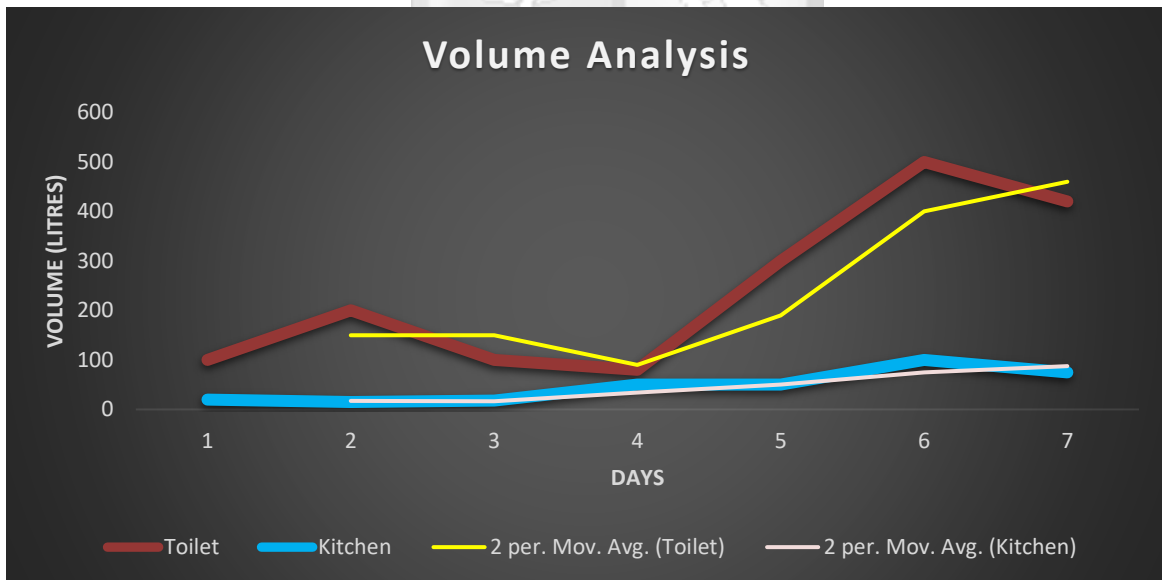
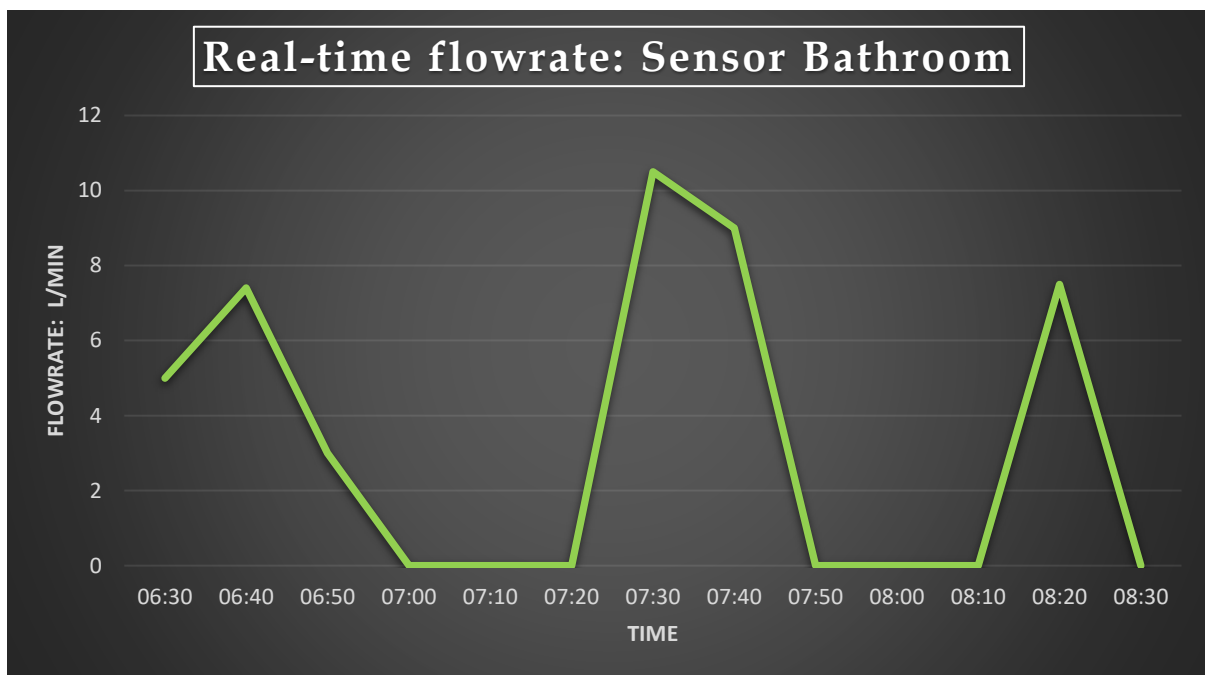


Figure 3.6 Comparing average volumes with actual volume

Figure 3.6 illustrates a moving average graph that's based on the number of days analysed. This graph helped establish a baseline for the average amount of water consumed. The system then calculated the standard deviation to set a threshold for water consumption. When this threshold was exceeded, the system sent alerts to the user to notify them of the deviation.

Figure 3.7 illustrates real-time flow rate data exported to CSV and data represented in a line chart between 6:30 am – 8:30 am in the morning. The water sensor captured is the bathroom:



**Figure 3.7 Real-time flow rate**

### 3.4 System Analysis

The system analysis involved the evaluation of real-time datasets, data analysis tools, water sensors, communication networks, decision-making algorithms, user applications, and real-time transmission to a cloud database. It also involved examining how they all interacted with each other.

### 3.4.1 Context Diagram

The water management system's high-level design was presented using a context diagram. The system was created using IoT technology, which involved utilizing sensors to collect and transmit various data such as flow rate, time, water volume, and source of the water faucet. Wi-Fi was used for communication. The software application platform was cloud-based, and all collected data was uploaded and stored there. Additionally, the cloud platform featured visualization tools and data analytics algorithms. Alerts and notifications were generated from the cloud-based application to inform users of potential wastage.

### 3.4.2 Data flow diagrams

Data flow diagrams were used to model how data flowed through the system. Data flow diagrams showed the data input and output, data stores, and all the different subprocesses that data moved through. Data input came through the water sensor module and was automatically recorded in the database. The data was then analysed and calculated by the application backend to come up with an anomaly rating. Reports on water usage consumption were generated to be viewed via a web interface. Depending on the anomaly rating, alerts were then generated and sent via SMS and email.

### 3.4.3 Use case diagrams

To clearly illustrate the system interaction with all the actors and their impact, use case diagrams were used. There were two levels of actors: actors providing input and actors receiving or querying output.

### **3.4.4 Sequence diagrams**

Sequence diagrams were used to illustrate the time and order of events. In this prototype, the main focus was on detecting water consumption and wastage. The sequence started from the water flow sensor input and ended when the alert was sent to the user.

### **3.5 System Implementation**

The system consisted of a water flow sensor connected to a microcontroller, management module, mobile application, cloud database and storage and alert system for mobile notifications and email. Reporting tools were used for consumption reports and water usage analytics.

### **3.6 Testing and Validation**

Both unit and system testing were conducted on the system. Using the iterative approach, continuous improvement and validation was done throughout the system implementation, from data collection to report generation.

### **3.7 Dissemination and Utilization of Results**

To effectively communicate, utilize, and implement the findings of the study to improve water management and reduce water wastage in households, three steps will be involved in disseminating and utilizing the results. Firstly, the results will be published in the Strathmore University Library Repository to enable other researchers to access and utilize them. Secondly, policymakers and utility companies could be engaged to leverage the results and advocate for their inclusion in policies aimed at improving water management practices in the country. Finally, the study's recommendations can be used to encourage various stakeholders to take action to address water wastage in households using IoT solutions.

### 3.8 Ethical Issues

Previous work done by various researchers is acknowledged and cited accordingly. Any figures and tables from various public sources online have been cited with permission to use during this educational research. The Strathmore University Institutional Ethics Review Committee reviewed and approved the study proposal. On 12th April 2023, the approval certificate for the study was received, and it is attached in Appendix B.



## Chapter 4 : System Analysis, Design & Architecture

### 4.1 Introduction

This chapter describes the general architecture and design of the prototype with a comprehensive analysis of the solution. Mobile application functionality, networks, SMS, email alerts and web application development were incorporated, with a user-centric approach to generate a smart water management system giving real-time water usage.

### 4.2 Requirements Analysis

The requirements analysis examined what was needed by the researcher to meet the study objectives earlier depicted. The specific requirement being the development of a smart water management system that manages and controls household water usage.

#### 4.2.1 Functional Requirements

Focusing on the challenges experienced by both the water service providers and household users in a country where water usage consumption is not provided in real-time, the following were deemed to be the appropriate functional requirements for the smart water management system:

- i) User needs to login to the system. Mandatory fields are the Name, email address and mobile number.
- ii) The water management system will receive real-time water usage data, by locally provisioned smart sensors and securely stored in a cloud storage provider.
- iii) The system will validate the water usage data stored by comparing the current usage data with the thresholds set and computing any abnormalities for decision making.
- iv) The system will be able to send timely alerts via mobile notifications and Email; whichever the user prefers as the alert system.

- i) The system will avail relevant reports on request, pertaining to the user's water usage. These include, daily, weekly or monthly usage, high and low consumption days within a period, water fittings with the highest consumption.
- ii) The system will give analysed data to the user, in the form of graphs and tables to be used for planning purposes.

#### **4.2.2 Usability Requirements**

The target users of the solution were household water users – owners or tenants. The communication between the users and the system is simple and interactive whether through the mobile application or web portal for the administrators. Dashboards, usage alerts and reports are customizable based on what the user wants to view, this was a key element in ensuring that the system navigation was focused on the user experience.

#### **4.2.3 Supportability Requirements**

Both hardware and software are built from open-source communities. Regular system updates are provided to the users, which include security patching and enhanced functionalities. This ensures that users are kept up to date on all updates pertaining to vulnerabilities identified and ease of use/enhancements made.

#### **4.2.4 Non-functional Requirements**

The non-functional requirements of the system will deal with its quality aspect. The requirements are: -

- i. **Performance:** The application is delivered as a Platform as a Service (PaaS) and hosted in the cloud. PaaS is a cloud computing model where a third-party provider, in this case BlynkCloud, offers a platform for developers to build, run, and manage applications without the need to worry about underlying infrastructure, operating systems, or middleware. BlynkCloud has provided a cloud-based platform for building and

deploying Internet of Things (IoT) applications that provides efficient resources, ensuring the performance, availability, and reliability of the application.

- ii. **Scalability:** The system is scalable in that it has the provision to accommodate more sensors on the water fittings, more devices, expand storage capacity and can integrate with both old and new water infrastructure. The households do not need to change their faucets to incorporate the smart water management system.
- iii. **Manageability:** The system has an easy-to-use management interface for administrators which enables them to manage users, manage devices and manage alerts/events in the system. The system updates are also easy to install as the documentation is provided once the update is made available.
- iv. **Reliability:** The system can receive real-time water usage data, transmit it, and display it on the dashboard. It can also generate real-time alerts to the user when an event occurs. Moreover, the system's cloud hosting enables easy access to the app and guarantees 24/7 system uptime.
- v. **Security:** Access to the system is limited to authorized users and regular patching of the firmware and software is available and updated once released. The data transmission to the cloud is encrypted and uses a secure channel to upload to the cloud.

### **4.3 Application Architecture**

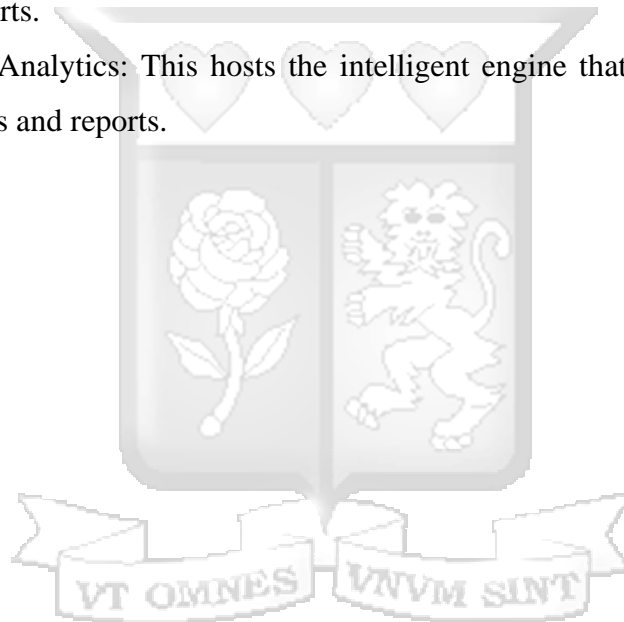
The system architecture gives an overview of how the various modules interact. As depicted in Figure 4.1, the different modules are described as follows:

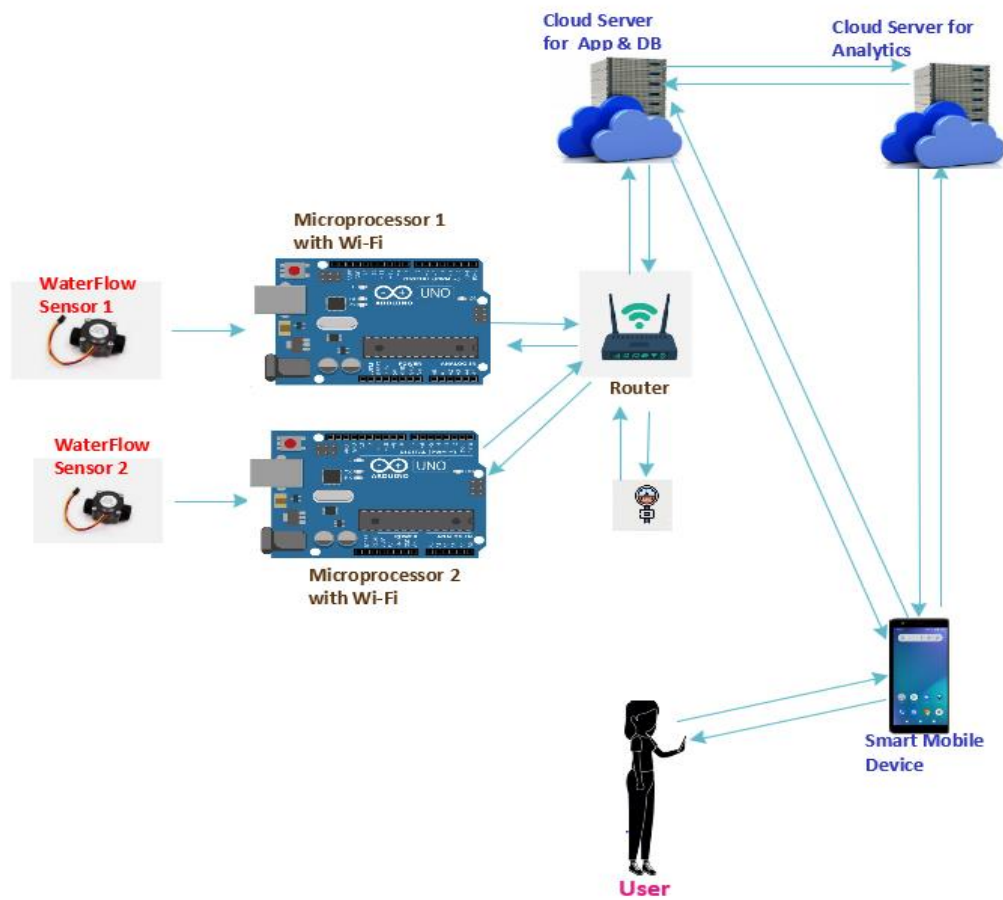
- i. **Waterflow sensor** is fixed on the direct line of the water faucet to detect any water flow. It uses a water rotor and a hall-effect sensor. When water flows through the rotor, the rotor spins, and the speed changes with the different flow rates. The hall-effect sensor outputs the corresponding pulse signal, and this is calculated to get the flow rate of water going through the sensor in litres/minute.
- ii. **Node MCU with Wi-Fi**, which is a programmable board receives the data, performs a calculation of the pulse signals using a calibration factor of 6.6 as per the model of the

water flow sensor, and forwards it to the gateway using the Wi-Fi module. The equation used to calculate the flow rate is as shown:

$$\text{Flow rate (L/min)} = (\text{Output pulse rate} / 6.6)^{(1/2)}$$

- iii. Router: This provides the link to the internet. It transmits the sensor data to the cloud servers containing the water management application and data analytics.
- iv. Cloud server: the cloud server hosts the application and database. It processes the data received and acts per the predefined conditions.
- v. Mobile Application Programming Interface (API): The Mobile (API) offers the user interface in the form of a dashboard for data visualization, receiving alerts, and retrieving reports.
- vi. Cloud Server Analytics: This hosts the intelligent engine that will be used for data analysis, trends and reports.





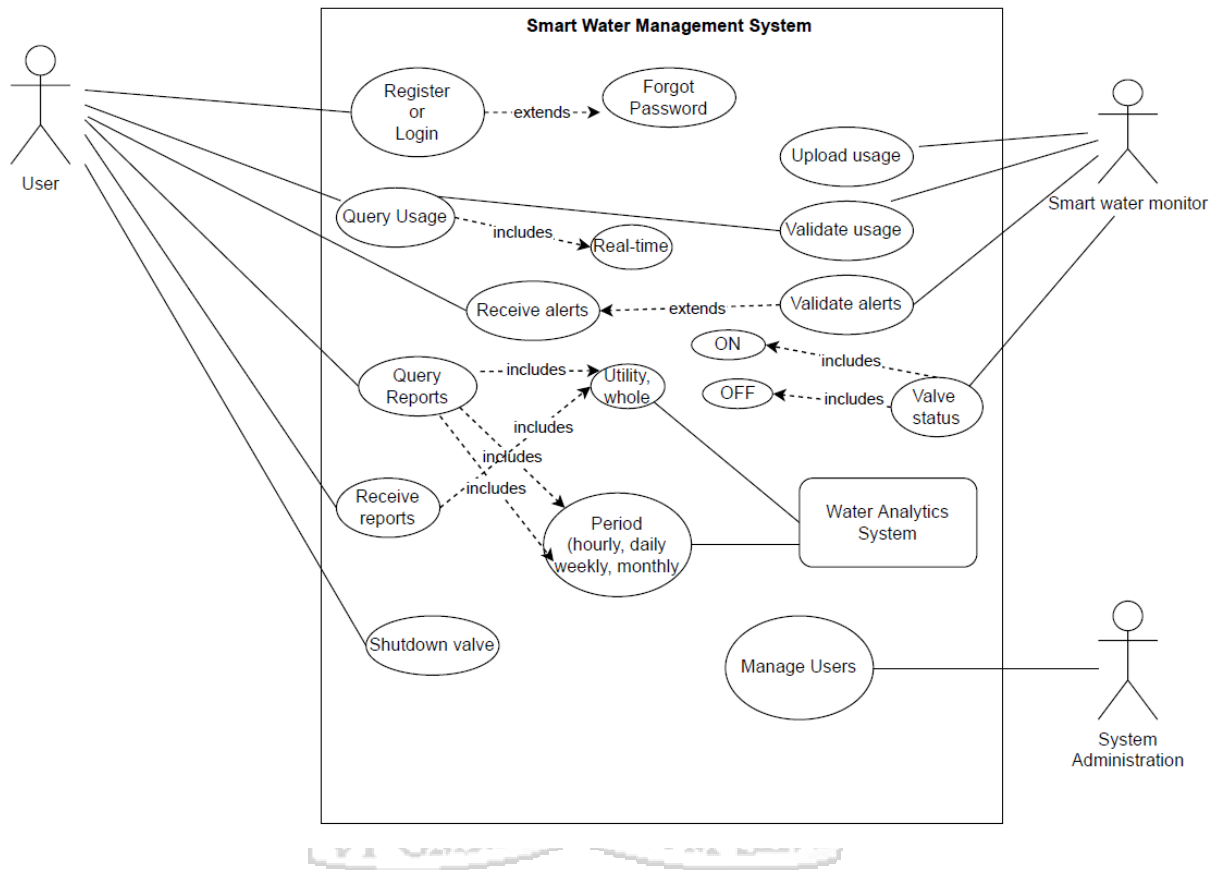
**Figure 4.1 Application Architecture**

## 4.4 System Design

### 4.4.1 Use Case Diagram

A Use case is a description and record of how the user interacts with the system to accomplish a specific task that the user has requested. It outlines the system's functionalities and can be utilized to generate additional functional requirements.

For example, once a user registers on the system, they can then log in and gain access into the system. This gives them a view of the real-time water usage data on the dashboard. Meanwhile, the administrator can manage the users. Figure 4.2 illustrates the Use Case Diagram used for the smart water management system for detecting household water wastage.



**Figure 4.2 Use Case Diagram**

### Use Case Descriptions

This section offers comprehensive explanations of the use cases mentioned in the diagram using the fully dressed format with two columns as shown in Table 4.1.

**Table 4.1 Use Case Descriptions**

Use case	Login
Primary Actor	System user
Post-conditions	The user is successfully authenticated
Main success scenario	
Actor Intention	System Responsibility
1. User enters his email address and password	
	2. System authenticates the user
Extensions	
<ul style="list-style-type: none"> <li>• When a user does not exist, the user will be prompted to register into the system.</li> <li>• When a user forgets their password they will go through a password recovery process by providing either their email address or phone number</li> </ul>	
Use Case	Retrieve Real-time Usage
Primary Actor	System user
Post-conditions	The user retrieves real-time usage
Use Case	Validate and send Alerts
Primary Actor	Smart water system
Post-conditions	System sends an abnormal usage alert
Use Case	Receive Alerts
Primary Actor	System user
Post-conditions	User receives abnormal usage alert

### 4.4.2 Sequence Diagram

The sequence diagram in Figure 4.3 shows the order of operations from start to finish. When a user signs up to use the system, they are asked to provide their email address and create a strong password on a registration form. If the sign-up process is successful, the user can log in and choose to view their real-time water usage data or periodic usage. At the same time, the events processor function constantly operates to determine the volume and flow of usage. If usage is found to be high or above the known average, the system will automatically create alerts and send them as notifications to the user's mobile device and email address.

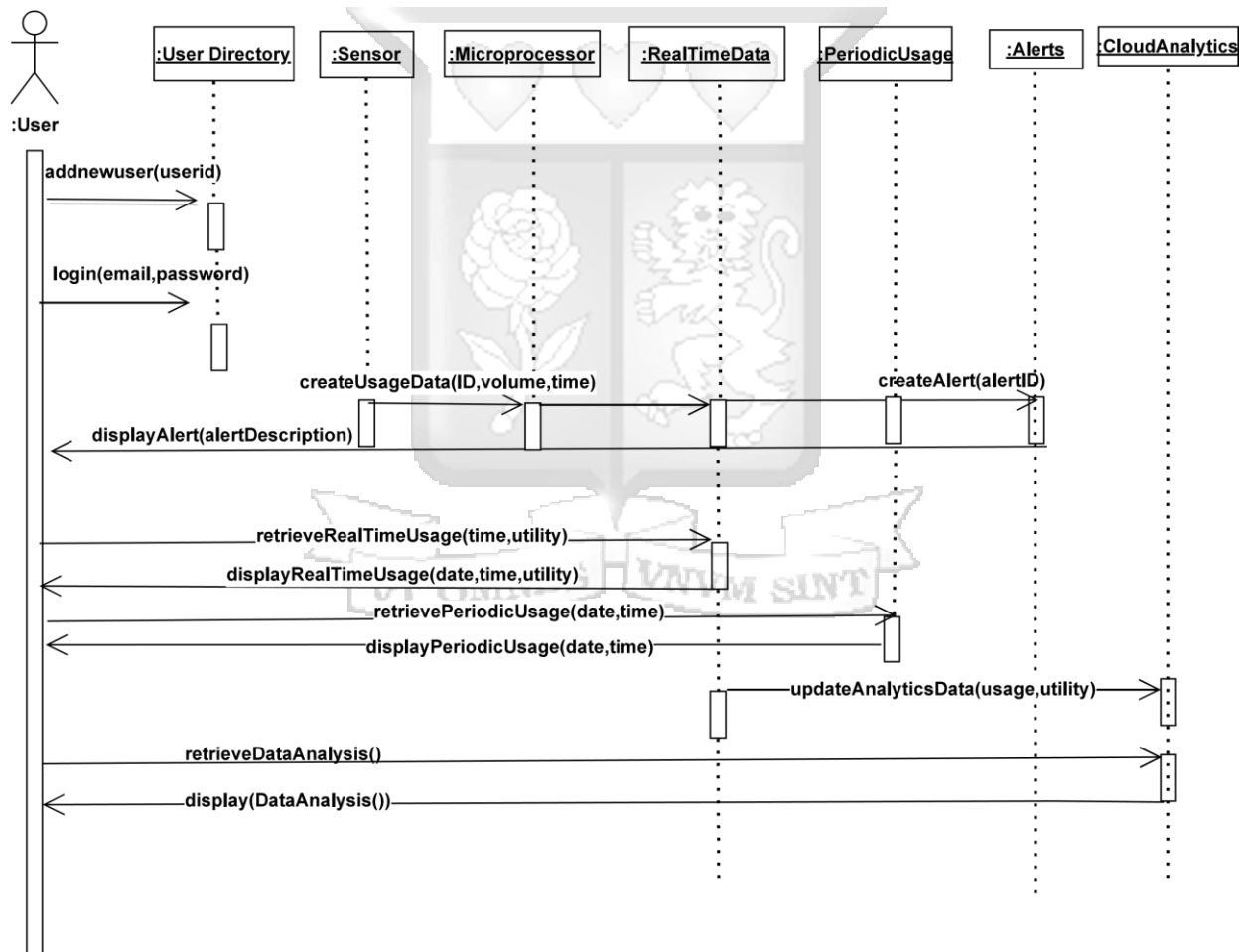


Figure 4.3 Sequence Diagram

### 4.4.3 Data flow diagram

The data flow diagram presented displays the movement of data through various subprocesses, as well as the data input, data output and data storage components. Figure 4.4 depicts the data input, output, and storage elements of the water management system that was created.

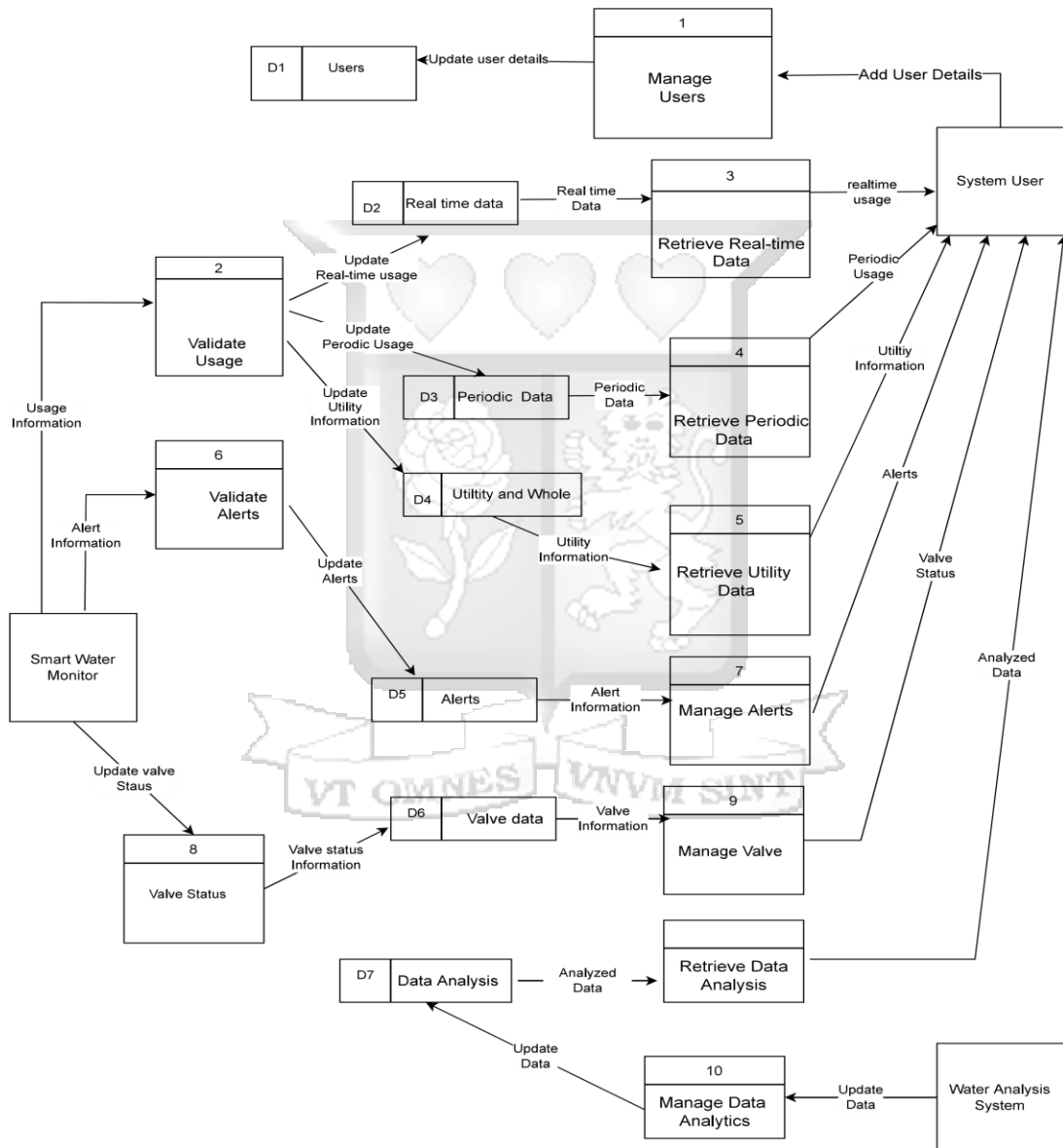
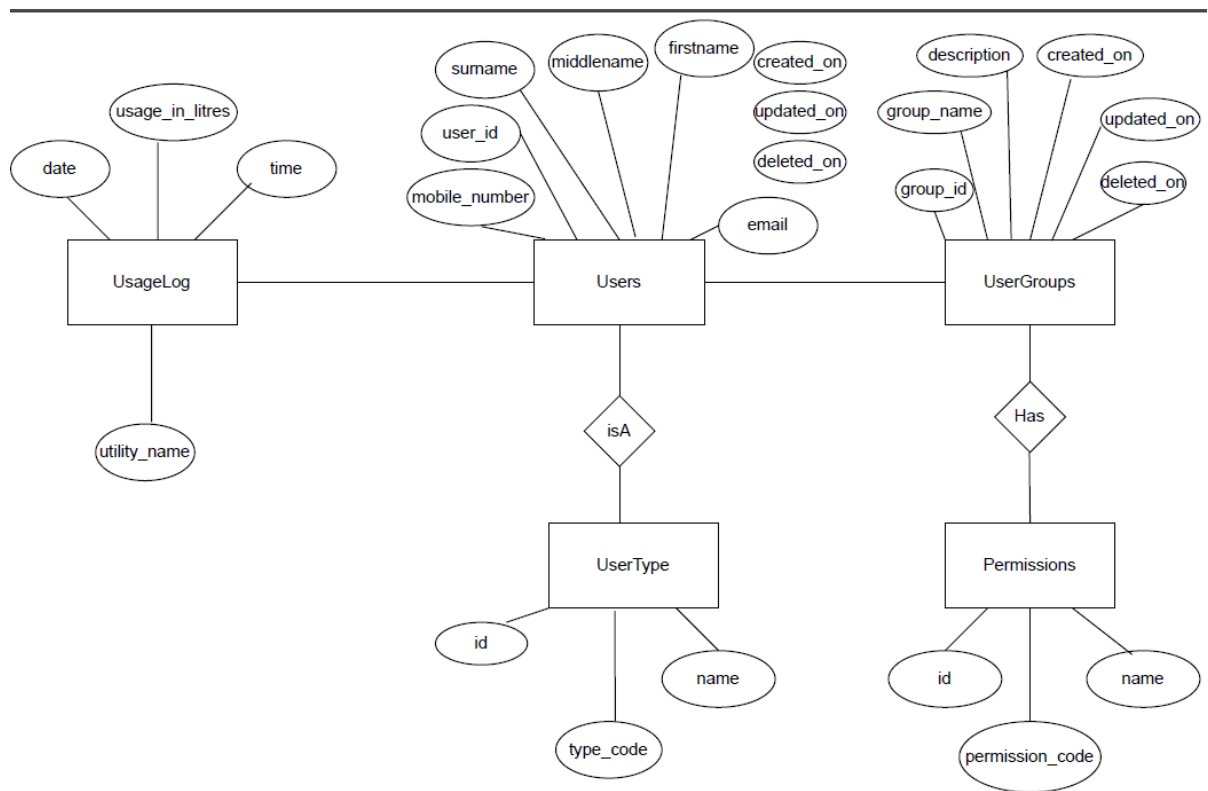


Figure 4.4 Level 1 Data flow diagram

#### 4.4.4 Entity Relationship Diagram

The Entity Relationship Diagram utilizes a diagrammatic representation to illustrate the configuration of the database, depicting the relationships among various entities. An example of this would be the connections between different system users and their respective user groups, as depicted in Figure 4.5.



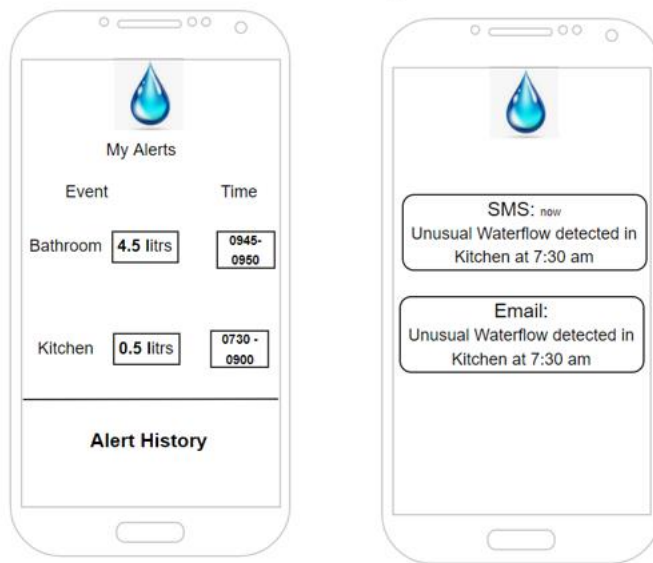
**Figure 4.5 Entity Relationship Diagram**

#### 4.4.5 Wireframes

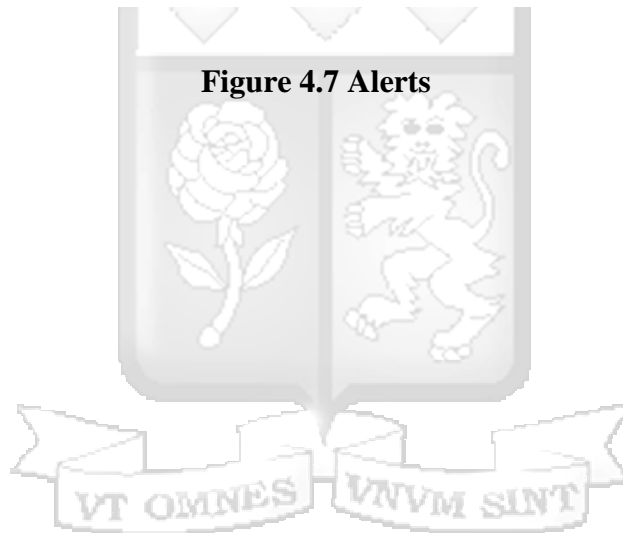
Figures 4.6 and 4.7 presented visual representations of the system in the form of wireframes for the mobile application. These wireframes illustrated the login pages, dashboards, and alerts that constituted the blueprint for the water management system.



**Figure 4.6 Login, Dashboard**



**Figure 4.7 Alerts**



## Chapter 5 : System Implementation and Testing



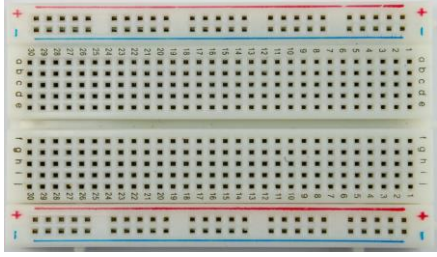
### 5.1. Introduction

The main focus of this chapter is on the approach that was used to implement and assess the development of the Smart Water Management system. The implementation covers a variety of functions within the prototype and provides an explanation of the software and hardware environments used during the testing phase and rolling out to production.

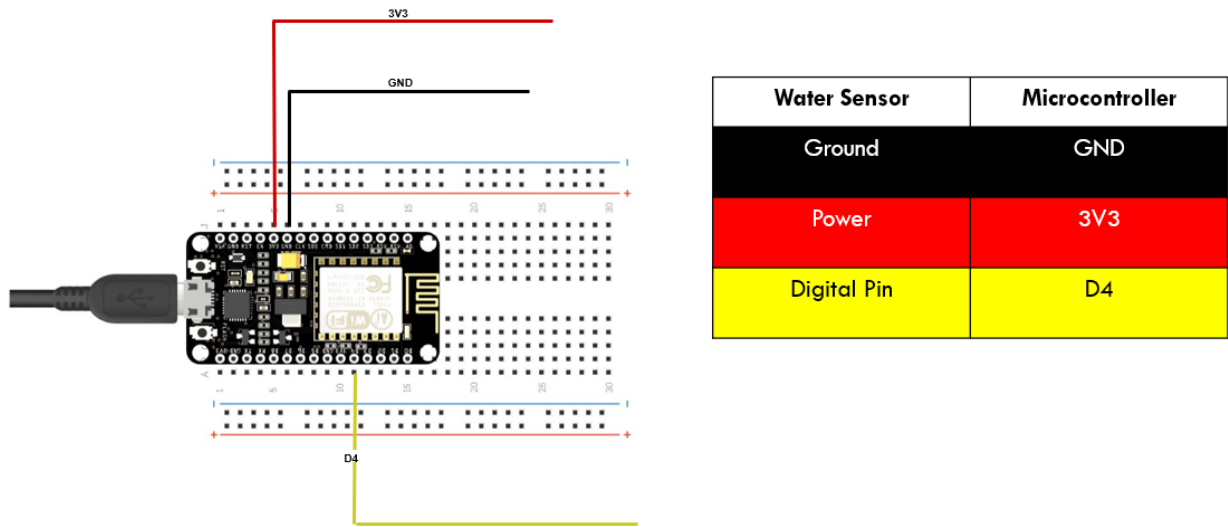
### 5.2. Hardware Environment

The data acquisition unit is managed by the **NodeMCU**, an open-source platform for Internet of Things (IoT) which runs on the **ESP8266 Wi-Fi** system module. To monitor water flow, the NodeMCU interfaces with a **DN20 Copper flow water sensor** which is installed in line with the water faucet. This sensor uses a **pinwheel** to measure the amount of water flowing through it. The pinwheel has an integrated magnetic **hall-effect sensor** that produces an electrical pulse with every revolution. The NodeMCU is the preferred option for designing the data acquisition unit because it only acquires data periodically based on its configuration and sends it in real-time to the **Cloud server** that hosts the application, without requiring data processing. To create the electronic circuit for the prototype, a breadboard was used. The hardware components were connected and configured on a laptop running Windows 11, 16GB RAM and i7 intel Core processor, before being implemented on the faucet.

**Table 5.1 The core hardware components**

	<p><b>The NodeMCU ESP8266</b> is a versatile and powerful microcontroller.</p> <ul style="list-style-type: none"> <li>i. Low-cost Wi-Fi module</li> <li>ii. Supports 2.4GHz Wi-Fi networks.</li> <li>iii. Can operate up to a range of 100metres</li> </ul>
	<p><b>The Copper Water Flow Sensor</b> is a durable and corrosion-resistant device designed to measure the flow rate of water in a pipe.</p> <ul style="list-style-type: none"> <li>i. Can withstand high pressure.</li> <li>ii. Uses a hall effect sensor to detect the rotation of a turbine and generates a series of pulses.</li> <li>iii. Flowrate measured as a factor of pulses.</li> <li>iv. Has a high level of accuracy, error rate <math>\leq 3\%</math> at low flow rates and <math>\leq 1\%</math> at high flow rates.</li> </ul>
	<p>A <b>breadboard</b> was used for building the electronic circuit for the prototype</p>

A demonstration of the NodeMCU attached to the breadboard with corresponding jumper wires for power and digital inputs is as illustrated in Figure 5.1.



**Figure 5.1 NodeMCU attached to breadboard.**

### 5.3 Software Environment

The water management system is hosted in Blynk IoT Cloud. This is an open-source platform that provides solutions for building IoT projects. The water sensor and Wi-Fi module were first connected and configured on a laptop running Windows 11 using Arduino Integrated Environment. The Arduino firmware was coded in C++ and the code uploaded to Blynk IOT cloud. The mobile app is as well hosted on the Blynk IOT cloud with the API written in JavaScript and data is stored in file systems.

### 5.4 Roles and Permissions

The different user roles and permissions have been implemented into the system by ensuring that every system user has been assigned specific roles and permissions. Different users have different views and privileges depending on the roles assigned to them. The two main users are Super administrator who has full access to the online platform and can manage IoT devices, manage users, add, edit or delete configurations and code, upload configuration changes and

manage visualization and analysis. The other user is a *guest user* who will only view their dashboard, visualization and reports. Figure 5.2 shows the interface for managing users and devices.

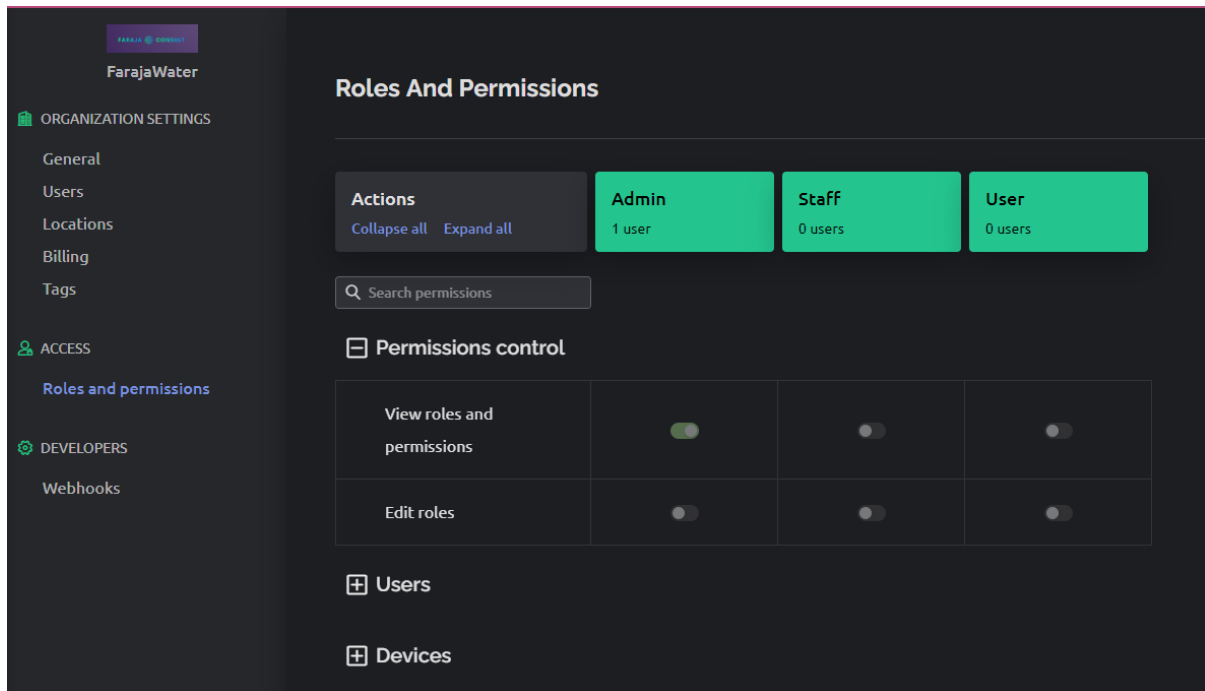
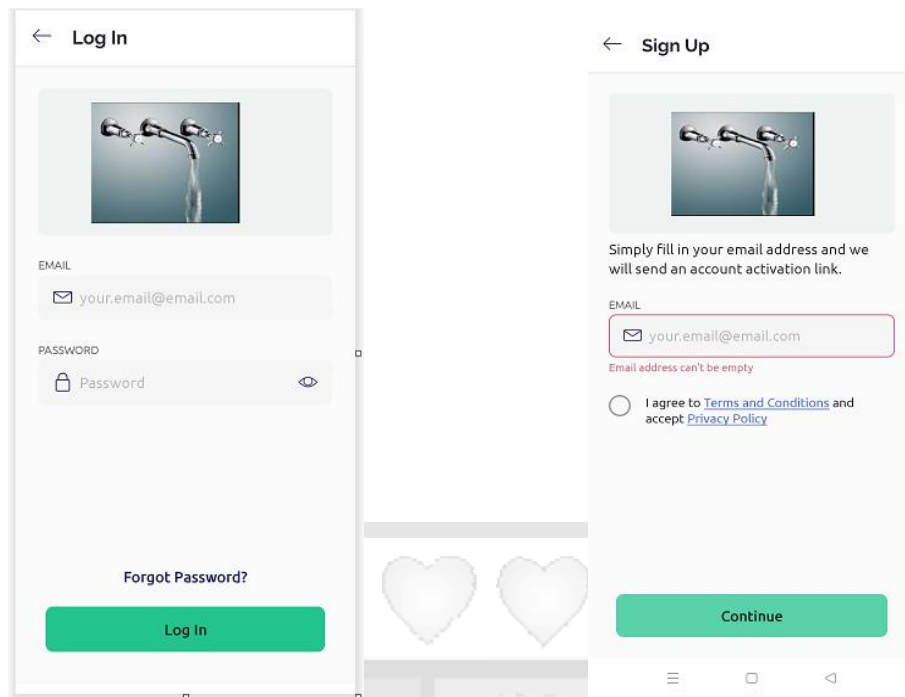


Figure 5.2 Module for managing users and devices

## 5.5 System Modules

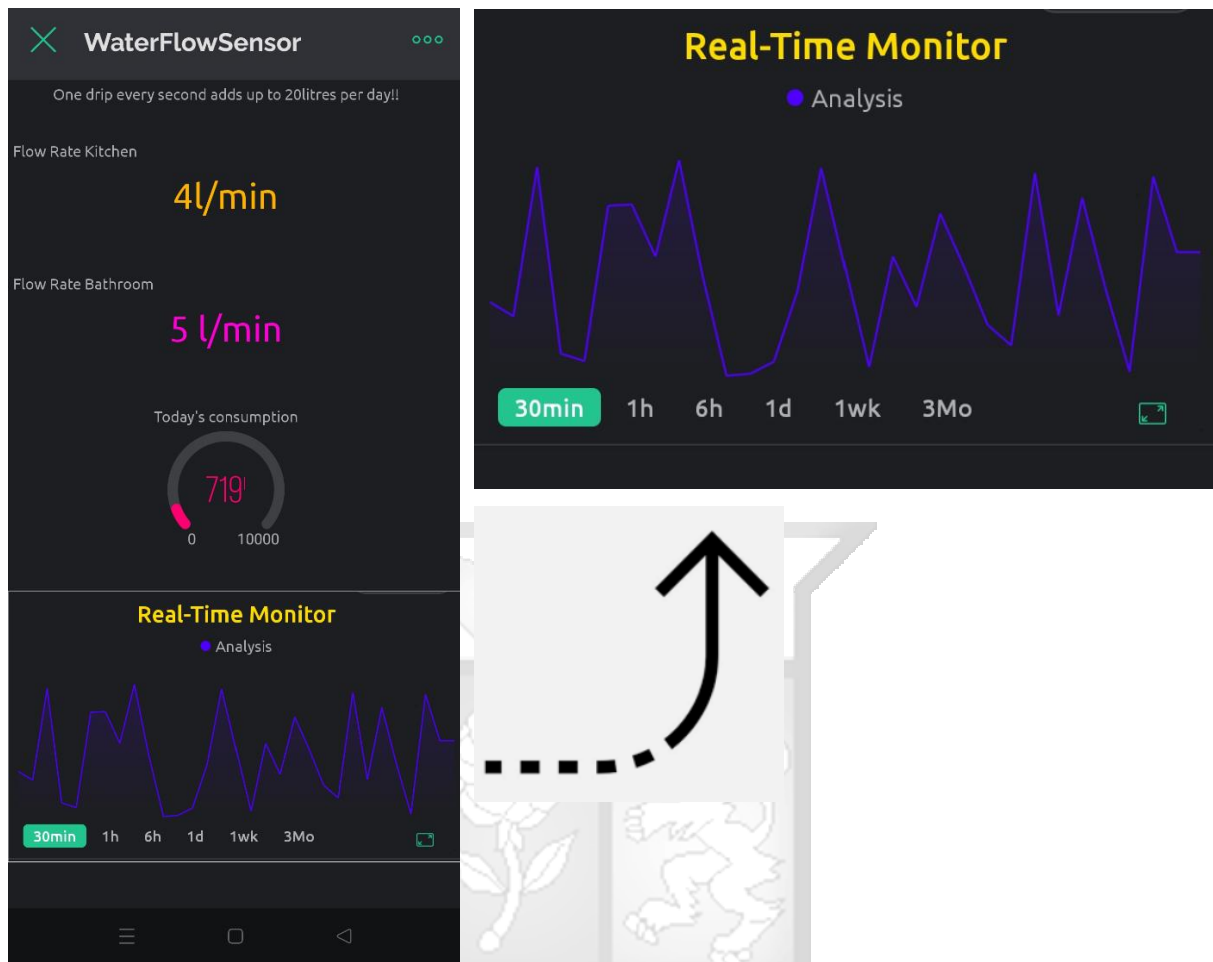
The mobile application login and sign-up page are shown in Figure 5.3. To use the mobile app the user needs to sign up and login to manage their respective devices.



**Figure 5.3 Login and Registration module.**

Once a user login they are then directed to the devices page depending on their permission settings. An administrator will get to have a view of all the devices that have been setup.

After the user chooses the device they wish to access, they will be directed to their dashboard. The standard dashboard for an average user is shown in Figure 5.4. It displays the water flow rates for the areas of interest, namely the bathroom and kitchen, as well as the volume of water used in litres and a real-time view of the water flow. Moreover, the dashboard includes a useful water-saving tip that changes every day, informing the user of effective conservation measures that have been tested and proven.



**Figure 5.4 User Dashboard**

The events menu shown in Figure 5.5, enables the user to generate alerts for water usage. This is a crucial feature of the system because it promptly notifies the user of any water wastage.

**WaterFlowSensor**

Info Metadata Datastreams **Events** Automations Web Dashboard Mobile Dashboard

Search event

Id	Name	Code	Color	Type	Description
1	Online	online	Green	Online	
2	Offline	offline	Red	Offline	
3	WaterRunning	waterrunning	Orange	Warning	FlowRate for more than 3 minutes

**Figure 5.5 Events and alerts generator module**

## 5.6 Hardware Configuration and Uploads

The system involved the configuration of water flow sensors and NodeMCU microcontroller boards. Figure 5.6 shows the upload of code to the NodeMCU microcontroller. Once this code is uploaded the microprocessor is able to calculate the flow rate and water volume from the water flow sensor.



```
WorkingSensor.ino
52     if (currentMillis - previousMillis > interval) {
53         pulse1Sec = pulseCount;
54         pulseCount = 0;
55         flowRate = ((1000.0 / (millis() - previousMillis)) * pulse1Sec) / calibrationFactor;
56         previousMillis = millis();
57         flowMillilitres = (flowRate / 60) * 1000;
58         totalMillilitres += flowMillilitres;
59         Serial.print("Flow rate: ");
60         Serial.print(int(flowRate));
61         Serial.print("L/min");

```

Output

```
Auto-detected Flash size: 4MB
Compressed 291104 bytes to 212725...
Writing at 0x00000000... (7 %)
Writing at 0x00004000... (15 %)
Writing at 0x00008000... (23 %)
Writing at 0x0000c000... (30 %)
Writing at 0x00010000... (38 %)
Writing at 0x00014000... (46 %)
Writing at 0x00018000... (53 %)
Writing at 0x0001c000... (61 %)
Writing at 0x00020000... (69 %)
Writing at 0x00024000... (76 %)
Writing at 0x00028000... (84 %)
Writing at 0x0002c000... (92 %)
Writing at 0x00030000... (100 %)
Wrote 291104 bytes (212725 compressed) at 0x00000000 in 18.8 seconds (effective 123.6 kbit/s)...
```

**Figure 5.6 Compiling and uploading of code to the Node MCU**

Once the code has been uploaded to the Node MCU, the device is noted to be online in the Blynk App and any water flow data is then uploaded to the cloud, to be viewed in the dashboard by the user. Figure 5.7 illustrates real-time data of water flowing from the Arduino IDE serial monitor interface. This is the same data that will be shown in real-time on the user's dashboard.

```
23:33:55.105 -> Flow rate: 0L/min      Output Liquid Quantity: 7L
23:33:56.102 -> Flow rate: 1L/min      Output Liquid Quantity: 25L
23:33:57.088 -> Flow rate: 1L/min      Output Liquid Quantity: 50L
23:33:58.091 -> Flow rate: 1L/min      Output Liquid Quantity: 79L
23:33:59.080 -> Flow rate: 1L/min      Output Liquid Quantity: 104L
23:34:00.097 -> Flow rate: 3L/min      Output Liquid Quantity: 163L
23:34:01.116 -> Flow rate: 3L/min      Output Liquid Quantity: 229L
23:34:02.120 -> Flow rate: 3L/min      Output Liquid Quantity: 291L
23:34:03.122 -> Flow rate: 1L/min      Output Liquid Quantity: 324L
23:34:04.111 -> Flow rate: 0L/min      Output Liquid Quantity: 324L
23:34:05.121 -> Flow rate: 0L/min      Output Liquid Quantity: 324L
23:34:06.108 -> Flow rate: 0L/min      Output Liquid Quantity: 324L
23:34:07.128 -> Flow rate: 0L/min      Output Liquid Quantity: 324L
```

**Figure 5.7 Sample of real-time data from the Arduino IDE serial interface**

## **5.7 System testing and application**

### **5.7.1 Unit and Functional Testing**

Unit testing was done on the water flow sensor attached to the bathroom water closet, to the NodeMCU board and connected to a power source. Figure 5.8 shows an image of the water flow sensor connected to the NodeMCU board and the LED lights on in the bathroom, indicating that power was reaching the board.



**Figure 5.8 Prototype connected to the bathroom to monitor consumption.**

Table 5.2 shows the testing done on the core functionalities which included a test case, observed behaviour and a conclusion to indicate whether the function worked or not.

**Table 5.2 Functional Testing**

<b>Function</b>	<b>Test case Description</b>	<b>Desired Behaviour</b>	<b>Observed Behaviour</b>	<b>Error</b>	<b>Conclusion</b>
User Registration	Checking if the system allows the home user to log in.	The user should successfully login into the system.	Users can login into the system successfully when correct credentials are entered	None	Function OK
Flow Data acquisition	Checking to see if water flow data is being detected and acquired	Water flow data should be detected and recorded	Water flow was detected, recorded and represented in l/minute	None	Function OK
Water flow data upload	Checking to see if water flow data is being uploaded into the cloud	Water flow data should be uploaded	Water flow data was uploaded into the cloud as flow rate and volume	None	Function OK
Alert Generation	Checking to see if alerts are triggered after defined system events	Alerts should be generated bases on defined events	Alerts were triggered and sent to respective users based on defined events	None	Function OK
Analytics Usage Graph	Checking to see whether the system can receive and analyse the data	The system should receive data, store and analyse	The system was able to generate graphs which represented usage and was able to analyse the results	None	Function OK
Reports	Checking to see whether the system can generate usage reports	The system should be able to generate reports on usage	The system generated reports based on specified periods	None	Function OK

### 5.7.2 Compatibility Testing

Both hardware and software were tested on whether they were compatible with different operating systems. The hardware components were tested on a Linux and Windows machine to confirm whether the operating system would detect them. The cloud application is an open-source platform and could be used on both Android and IOS. Table 5.3 describes the compatibility testing done.

**Table 5.3 Compatibility Testing Results**

<b>Operating System</b>	<b>Compatibility</b>
Windows OS	Yes
Linux - CentOS /Ubuntu	Yes
Android	Yes
IOS	Yes

### 5.7.3 Usability Testing

The purpose of this test was to demonstrate the consistency and user-friendliness of the application flow. The layout of the dashboard and widgets in the mobile application has remained consistent in design and colour scheme from the beginning, making it easy for users to predict and use. Short and understandable messages were created to alert users of any system events that required attention. The water management system has successfully passed the usability test as it is easy to use on various portable devices.

### 5.7.4 Integration Testing

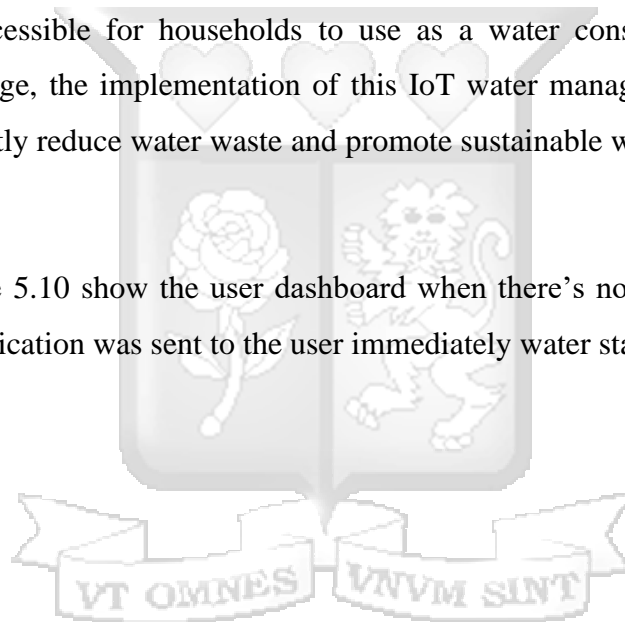
Integration testing of the water management system, which employed the water flow sensor, Node MCU and Blynk cloud application for detecting household water wastage, has been completed successfully. The testing verified the seamless integration of the hardware and

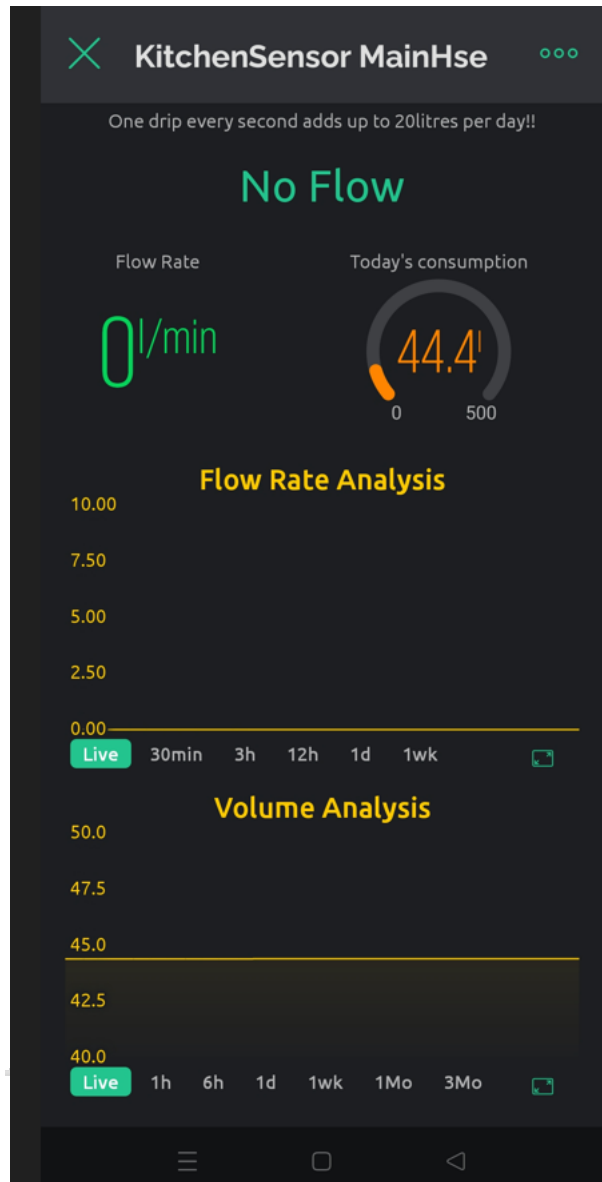
software components, allowing for real-time communication between the devices and cloud application. The system correctly identified instances of water wastage and delivered timely alerts to users. Overall, the integration testing has established the efficient functioning of the IoT water management system in detecting water wastage in households, thereby offering an effective solution for water conservation.

### 5.7.5 Validation

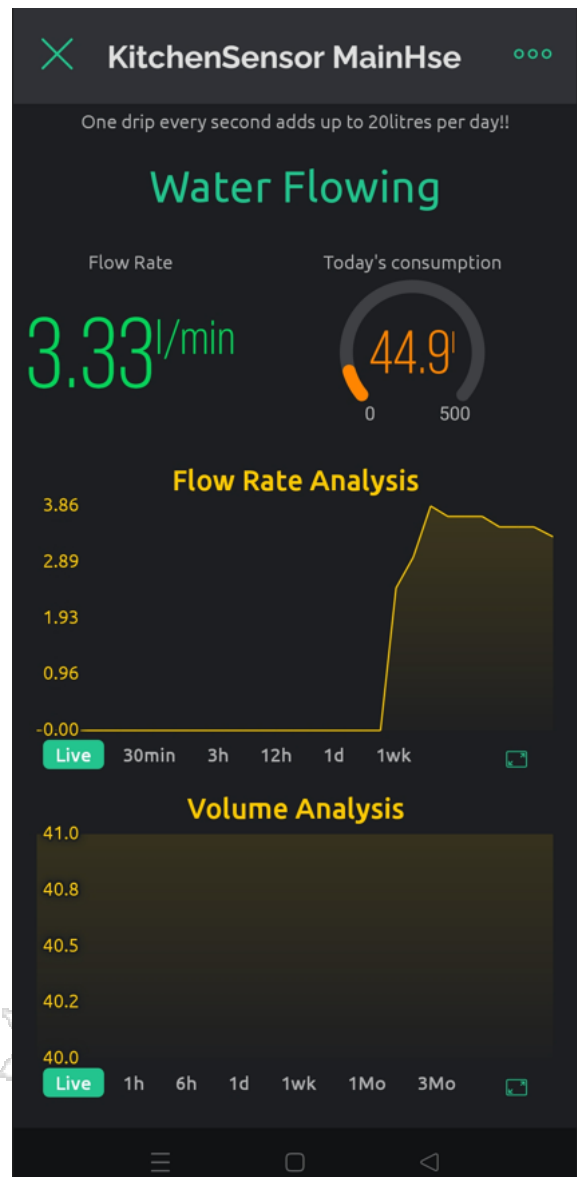
Validation testing authenticated the system's precision in detecting water wastage and sending immediate notifications to users. The system is designed to be user-friendly and simple to install, making it accessible for households to use as a water conservation solution. By detecting water wastage, the implementation of this IoT water management system has the potential to significantly reduce water waste and promote sustainable water usage practices in households.

Figure 5.9 and Figure 5.10 show the user dashboard when there's no flow and when water starts flowing. A notification was sent to the user immediately water starts flowing.



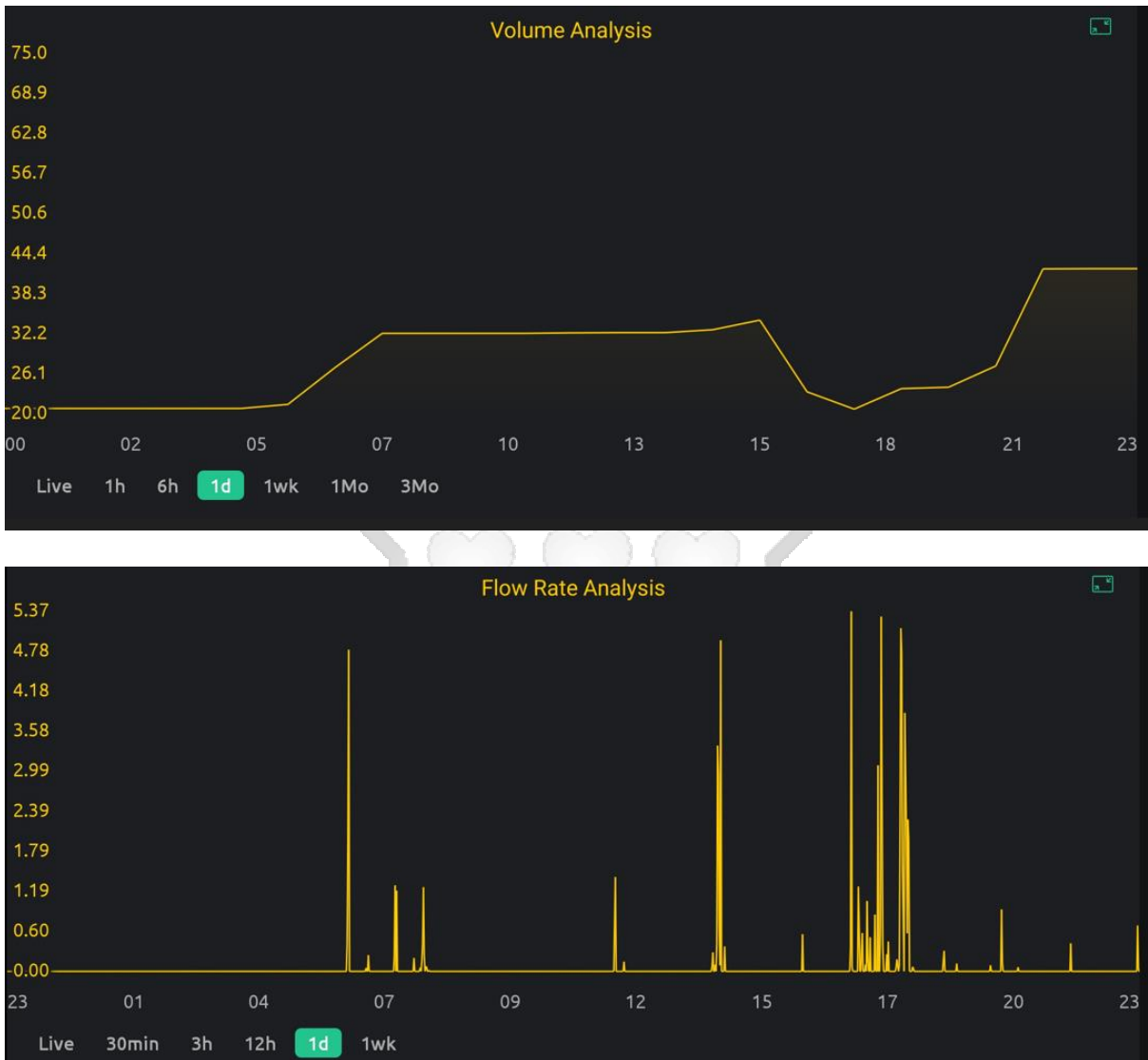


**Figure 5.9 Dashboard when no water is flowing**



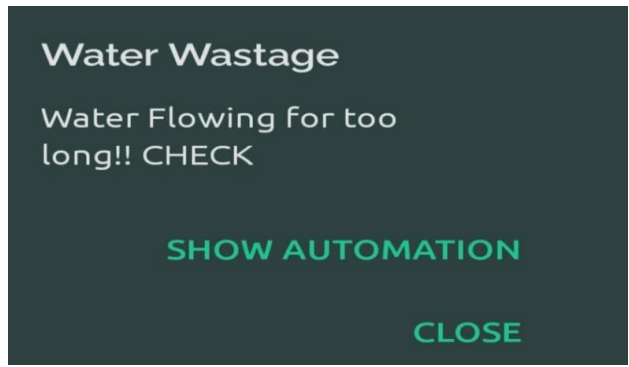
**Figure 5.10 Dashboard as Water is Flowing**

The graphs in Figure 5.11 were maximized from the dashboard and are used to view the analysis of the consumption throughout different time intervals. A user can select to view their hourly usage, daily, weekly, monthly or yearly water consumption all in one view. This presents the user with various usage trends which can prompt them to quickly adjust behaviour or identify any plumbing issues due to spiked usage.



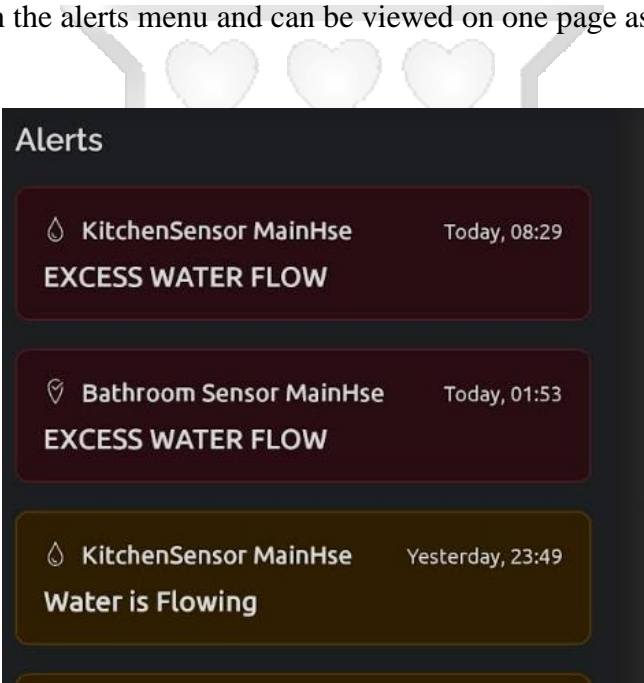
**Figure 5.11 Dashboard graphs**

A view of a sample alert sent to the user immediately after a threshold is reached and surpassed is illustrated in Figure 5.12.



**Figure 5.12 Blynk mobile alert**

All alerts are stored in the alerts menu and can be viewed on one page as shown in Figure 5.13



**Figure 5.13 Different alerts and Notifications**

## **Chapter 6 : Discussion**

### **6.1 Introduction**

The focus of this chapter is to discuss the study's results based on the objectives outlined in Chapter One. The objectives of the study were to analyse the different water management systems in use, identify the challenges that hinder water usage and wastage monitoring, develop a smart water management system that would control water wastage in homes, and test the prototype.

### **6.2 A Comparative Analysis of Water Management Systems**

The study examined the various water management systems that are currently in use. This was a crucial step in gaining insights into the methods adopted worldwide for preserving and managing this scarce resource. As Kenya frequently experiences extended dry spells, it is significantly affected by water shortages. As a result, there was a need to investigate how this resource could be utilized more efficiently. The analysis encompassed a wide range of global water management strategies and systems, including media campaigns to increase awareness, public participation efforts, water pricing strategies to encourage behavioural changes and technological innovations in water metering and monitoring systems. The findings revealed several challenges associated with water resource management.

### **6.3 Challenges Hindering Management of Water Usage and Wastage**

The investigation conducted in the study focused on the obstacles that hinder the monitoring of water usage and wastage. The primary hurdles that surfaced related to the behaviour patterns of individuals regarding their water usage. Some of the factors that influenced behaviour included their upbringing, lack of awareness that water is a scarce resource, and the belief that water is free-hence widely and readily available. The change in behaviour needed to begin with households and eventually spread to organizations and nations. To ensure sustainable water

practices, governments and policymakers must support the cause by enforcing regulations or promoting and financing awareness programs.

Regarding technological advancements, the difficulties faced were integrating them with current systems, insufficient financial support to scale the innovations, and lack of conclusive outcomes after implementing the water management solutions. There was also a gap noted when it came to real-time monitoring of water usage at faucet level, as most innovations focused on water billing and metering systems, which could not give real-time monitoring of water flow at the appliance level and alert users of potential leakages. These were the fundamental issues the researcher aimed to tackle.

#### **6.4 Detecting Water Wastage Using a Smart Water Management System**

To develop a smart water management system for detecting household water wastage, a user-friendly mobile app that integrated with a water flow sensor to provide real-time information on household water usage was implemented. The design of the system involved various tools such as Use Case Diagrams, Sequence Diagrams, Data Flow Diagrams, Entity Relationship diagrams, and Wireframes. The core functionalities of the system which were real-time monitoring, generation of wastage alerts and data analysis were successfully implemented. Due to time limitations, more accurate data analytics involving anomaly detection techniques, that require a much longer data collection period could not be attained. As a result, the researcher created a prototype of the same, ensuring the core functionalities were implemented and forming the baseline for analytics which can be done after a longer period has elapsed for precise anomaly predictions.

The developed system places the customer at the forefront of all operations. In Kenya, water utilities obtain information on household water usage by manually reading the water meters installed in the homes. By providing users with access to their own water usage data, they then have a sense of control in managing their water usage. This then allows them to use water more efficiently and prevent prolonged water leakages with the goal of conserving this rapidly

declining resource. The real-time alerts aim at promoting behavioural change by making household users aware of water wastage to nudge for prompt action.

The data shown in the graphs before and after the prototype was implemented indicate that the alerts had begun to have an impact on the household water usage, as can be seen on the moving average graphs which show a downward usage trend in both the kitchen and bathroom data after a span of a few weeks (Figure 6.1 and Figure 6.2).

The benefit analysis of the alerts, however, will require continuous collection of real-time data over a longer period to solidly confirm that the wastage alerts resulted in reduced water wastage.

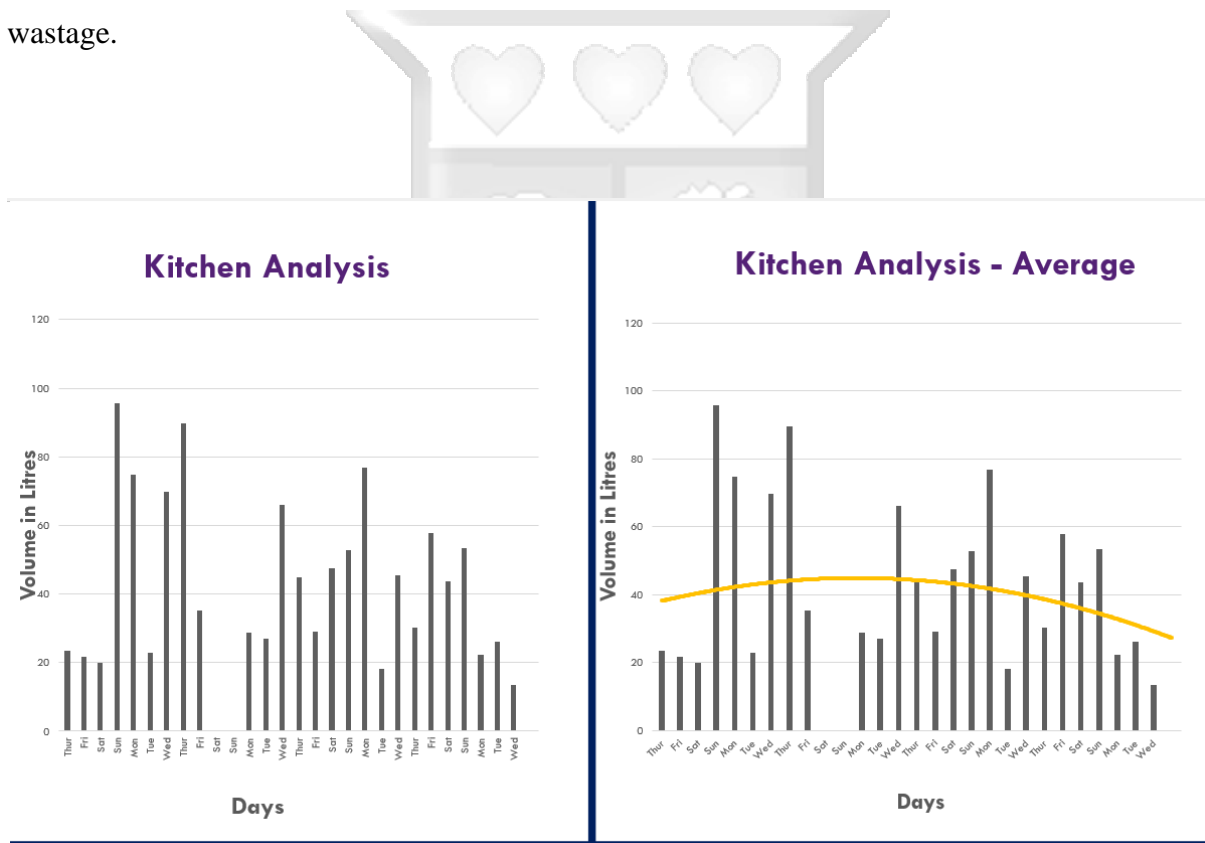
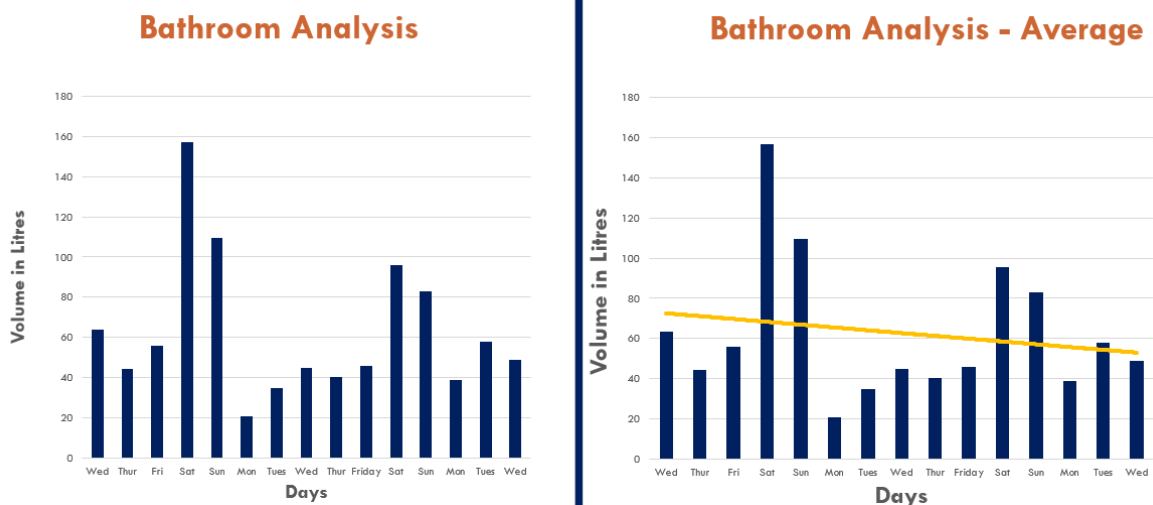


Figure 6.1 Kitchen Data analysis graph



**Figure 6.2 Bathroom Analysis**

### 6.5 Testing the Performance of the System

The final goal was to carry out a trial of the prototype to manage household water wastage. The study's Implementation and Testing Chapter, presented in Chapter 5, discusses the implementation, testing, and validation of the system. The research study documented the devices used, their performance, and the results obtained during testing. To ensure that the functionalities of the equipment were achieved, a test kit was developed and used. Subsequently, the test equipment was consolidated into one unit and implemented in the defined areas, namely, the kitchen and toilet, to obtain accurate usage data for analysis and generate usage and wastage alerts to users.

## **6.6 Practical Implications**

The findings of this study have several practical implications for water management in households. Firstly, the implementation of a smart water management system can significantly reduce water wastage in households. The system is able to detect leaks, monitor water usage, and provide timely alerts to homeowners when water is being wasted. This can help homeowners to identify and fix leaks quickly and to be more aware of their water usage patterns.

Secondly, the study highlights the importance of education and awareness-raising campaigns on water conservation. By providing households with information on the importance of water conservation and simple steps that can be taken to reduce water usage, through the “daily tips” section in the system, households can be empowered to take action to conserve water.

Thirdly, the study highlights the need for collaboration between water utilities, local authorities, and households to promote sustainable water management practices. Water utilities and local authorities can play a key role in promoting the adoption of smart water management systems and in providing incentives for households to conserve water.

Overall, the findings of this study suggest that the implementation of a smart water management system, coupled with raising awareness and collaboration between stakeholders, can lead to more sustainable water management practices in households. These findings have important implications for households, policymakers and water utilities and can be applied in real-world settings to promote sustainable water management practices.

## **6.7 Limitations of the System**

Due to the limited installation time available, the water management system designed was implemented in a small number of households. During the implementation of the water flow sensors, the selected households required plumbing services which required allocated time to

effectively implement the prototype, hence fewer households were installed. As a result, the insights that could be drawn from the study in terms of comparing usage from different households were limited. Nonetheless, the researcher was able to collect enough data points on individual household water usage for data analysis to depict the impact of wastage alerts on improved water conservation behaviour.



## **Chapter 7 : Conclusion and Recommendations**

### **7.1 Conclusion**

Water is a precious resource that is currently facing a global threat due to climate change. With the increase in droughts and the depletion of water sources, many countries, including Kenya, are experiencing severe water shortages. Although various mitigation and adaptation practices have been put in place, they often lack the necessary support and maintenance. This study was conducted to create a water management system that could detect and monitor water wastage in households. The system is designed to raise awareness about water consumption, alert users of potential leaks and wastage, and encourage prompt action. The study's results showed that when users were alerted to water wastage in their homes, they were more likely to take action to address the issue. The findings of this study are significant in promoting water conservation practices and can contribute to efforts aimed at ensuring the sustainable use of water resources.

### **7.2 Recommendations**

The study has demonstrated the potential of using IoT to promote water efficiency and integrate with existing infrastructure systems. The researcher has shown that an approach which allows for hardware innovations to integrate or extend to already existing infrastructure is vital for achieving changes from both an economic and social standpoint. Users are more likely to accept changes that are non-invasive and require minimal physical alterations. Recommendations for this study include:

- i. Expanding the research to other areas of the home, larger buildings and eventually counties beyond Nairobi using different communication protocols.
- ii. Encouraging water utility companies to support and collaborate with innovators of smart water management solutions to develop policies and standards for efficient water management.

- iii. Using pilot project approaches to scale up the system gradually and learn from each phase to understand the system's operation and benefits.
- iv. Conducting further usage studies to confirm the impact of feedback reports in Nairobi and create more opportunities for collaboration among researchers, utility companies, and public institutions.

### **7.3 Suggestions for Future Works**

There are several potential areas for future improvement that can be carried out after implementing a Smart Water Management System for detecting household water wastage.

Some of these include:

- i. Integration with other smart home technologies: The Smart Water Management System can be integrated with other smart home technologies, such as smart thermostats, smart lighting, and smart appliances, to create a more comprehensive home automation system.
- ii. Expansion to larger areas: The system can be expanded to cover larger areas, such as apartment buildings, commercial buildings, and entire neighbourhoods, to promote more efficient water use and conservation. This can then expand into using other wireless protocols such as LoRaWAN.
- iii. Integration with water utility companies: The system can be integrated with water utility companies to provide more accurate and timely data on water usage and wastage, enabling more effective management of water resources.
- iv. Mobile application enhancement: The mobile application can be enhanced to provide more features, such as personalized water usage targets, and community water conservation challenges, to promote more sustainable water use practices.

## REFERENCES

- Alshamrani, A., & Bahattab, A. (2015). A Comparison Between Three SDLC Models Waterfall Model, Spiral Model, and Incremental/Iterative Model. *International Journal of Computer Science Issues*, 12(1), 7.
- AQUASTAT. (2019). *Water Use in Kenya* [Website].  
<https://www.worldometers.info/water/kenya-water/>
- Cominola, A., Giuliani, M., Piga, D., Castelletti, A., & Rizzoli, A. E. (2015). Benefits and challenges of using smart meters for advancing residential water demand modeling and management: A review. *Environmental Modelling & Software*, 72, 198–214.  
<https://doi.org/10.1016/j.envsoft.2015.07.012>
- Dawson, I. K., Carsan, S., Franzel, S., Kindt, R., van Breugel, P., Graudal, L., Lillesø, J.-P. B., Orwa, C., & Jamnadass, R. (2014). *Agroforestry, livestock, fodder production and climate change adaptation and mitigation in East Africa: Issues and options*. World Agroforestry Centre (ICRAF). <https://doi.org/10.5716/WP14050.PDF>
- de Miranda Coelho, J. A. P., Gouveia, V. V., de Souza, G. H. S., Milfont, T. L., & Barros, B. N. R. (2016). Emotions toward water consumption: Conservation and wastage. *Revista Latinoamericana de Psicología*, 48(2), 117–126.  
<https://doi.org/10.1016/j.rlp.2015.09.006>
- Doemeland, D., & Trevino, J. (2014). *Which World Bank Reports are Widely Read?* The World Bank. <https://doi.org/10.1596/1813-9450-6851>
- Durand, T. G., Visagie, L., & Booysen, M. J. (2019). Evaluation of next-generation low-power communication technology to replace GSM in IoT-applications. *IET Communications*, 13(16), 2533-2540.

*Explore the Digi XBee Ecosystem.* (n.d.). Retrieved October 25, 2022, from <https://www.digi.com/xbee>

Fielding, K. S., Russell, S., Spinks, A., & Mankad, A. (2012). Determinants of household water conservation: The role of demographic, infrastructure, behavior, and psychosocial variables. *Water Resources Research*, 48(10), 2012WR012398. <https://doi.org/10.1029/2012WR012398>

Gazis, A. (2021). What is IoT? The Internet of Things explained. *Academia Letters*. <https://doi.org/10.20935/AL1003>

Hasan, H. H., Razali, S. F. M., & Razali, N. H. M. (2021). Does the Household Save Water? Evidence from Behavioral Analysis. *Sustainability*, 13(2), 641. <https://doi.org/10.3390/su13020641>

Ismail, H., Elabyad, R., & Dyab, A. (2022). Smart Residential Water Leak and Overuse Detection System Using Machine Learning. *2022 IEEE/ACS 19th International Conference on Computer Systems and Applications (AICCSA)*, 1–6. <https://doi.org/10.1109/AICCSA56895.2022.10017508>

Jin, G., Bai, K., Zhang, Y., & He, H. (2019). A Smart Water Metering System Based on Image Recognition and Narrowband Internet of Things. *Revue d'Intelligence Artificielle*, 33(4), 293–298. <https://doi.org/10.18280/ria.330405>

Kamaruidzaman, N. S., & Nazahiyah Rahmat, S. (2020). Water Monitoring System Embedded with Internet of Things (IoT) Device: A Review. *IOP Conference Series: Earth and Environmental Science*, 498(1), 012068. <https://doi.org/10.1088/1755-1315/498/1/012068>

*Kenya Renewable water resources, 1958-2021—Knoema.com.* (n.d.). Retrieved October 25, 2022, from <https://knoema.com/atlas/Kenya/topics/Water/Total-Renewable-Water-Resources/Renewable-water-resources>

Kuganesan Kumar, Moamin A.Mahmoud “*Monitoring and Controlling Tap Water Flow at Homes Using Android Mobile Application*”. *American Journal of Software Engineering and Applications*. Vol.6, No.6, 2017

Lu, P., Cao, X., Li, G., Huang, W., Leppäranta, M., Arvola, L., Huotari, J., & Li, Z. (2020). Mass and Heat Balance of a Lake Ice Cover in the Central Asian Arid Climate Zone. *Water*, 12(10), 2888. <https://doi.org/10.3390/w12102888>

Marathe, R., Tapale, M., Jadhav, V., Hulbatte, V., & Pawar, A. (2021). IoT based Water Leakage Detection using Smart Objects for Smart City. *2021 Third International Conference on Intelligent Communication Technologies and Virtual Mobile Networks (ICICV)*, 415–419. <https://doi.org/10.1109/ICICV50876.2021.9388562>

Mohammed Shahanas, K., & Bagavathi Sivakumar, P. (2016). Framework for a Smart Water Management System in the Context of Smart City Initiatives in India. *Procedia Computer Science*, 92, 142–147. <https://doi.org/10.1016/j.procs.2016.07.337>

Mudumbe, M. J., & Abu-Mahfouz, A. M. (2015). Smart water meter system for user-centric consumption measurement. *2015 IEEE 13th International Conference on Industrial Informatics (INDIN)*, 993–998. <https://doi.org/10.1109/INDIN.2015.7281870>

Patten, M. L. (2016). *Proposing Empirical Research* (0 ed.). Routledge.  
<https://doi.org/10.4324/9781315265865>

Quesnel, K. J., & Ajami, N. K. (2017). Changes in water consumption linked to heavy news media coverage of extreme climatic events. *Science Advances*, 3(10), e1700784. <https://doi.org/10.1126/sciadv.1700784>

- Ramos, H., McNabola, A., López-Jiménez, P., & Pérez-Sánchez, M. (2019). Smart Water Management towards Future Water Sustainable Networks. *Water*, 12(1), 58. <https://doi.org/10.3390/w12010058>
- Ramsey, E., Berglund, E., & Goyal, R. (2017). The Impact of Demographic Factors, Beliefs, and Social Influences on Residential Water Consumption and Implications for Non-Price Policies in Urban India. *Water*, 9(11), 844. <https://doi.org/10.3390/w9110844>
- Rutherford, I., & Finlayson, B. (2011). Whither Australia: Will Availability of Water Constrain the Growth of Australia's Population? *Geographical Research*, 49(3), 301–316. <https://doi.org/10.1111/j.1745-5871.2011.00707.x>
- Sanchis, R.; Díaz-Madroñero, M.; López-Jiménez, P.A.; Pérez-Sánchez, M (2018) Smart Water Flow Control and Monitoring System.. *International Journal of Engineering Research*, 6(13), 2.
- Sethi, P., & Sarangi, S. R. (2017). Internet of Things: Architectures, Protocols, and Applications. *Journal of Electrical and Computer Engineering*, 2017, 1–25. <https://doi.org/10.1155/2017/9324035>
- Shuang, Q., & Zhao, R. T. (2021). Water Demand Prediction Using Machine Learning Methods: A Case Study of the Beijing–Tianjin–Hebei Region in China. *Water*, 13(3), 310. <https://doi.org/10.3390/w13030310>
- Srivastava, A., Bhardwaj, S., & Saraswat, S. (2017). SCRUM model for agile methodology. *2017 International Conference on Computing, Communication and Automation (ICCCA)*, 864–869. <https://doi.org/10.1109/CCAA.2017.8229928>
- Sydney Water 2017. Water conservation report 2016-2017, NSW, Australia, Sydney Water.
- Sydney Water 2018. Water Conservation Report: 2017-2018. Sydney, NSW: Sydney Water.

Tapsuwan, S., Mankad, A., Greenhill, M., & Tucker, D. (2017). *The influence of coping appraisals on the adoption of decentralised water systems in Australia*. *Urban Water Journal*, 14(1), 45-52. (n.d.).

Thomas, C., & Sharp, V. (2013). Understanding the normalisation of recycling behaviour and its implications for other pro-environmental behaviours: A review of social norms and recycling. *Resources, Conservation and Recycling*, 79, 11–20. <https://doi.org/10.1016/j.resconrec.2013.04.010>

Water Services Regulatory Board. (2021). *Assessing the Impact of Water Services in Kenya (Report No. 14)*

World Bank. (2015). *Mind, Society and Behaviour: A World Bank Flagship Report* (Report No. 92863).

World Bank (2021). *PPPLRC Report*

Yang, L., Yang, S.-H., Magiera, E., Froelich, W., Jach, T., & Lapidou, C. (2017). Domestic water consumption monitoring and behaviour intervention by employing the internet of things technologies. *Procedia Computer Science*, 111, 367–375. <https://doi.org/10.1016/j.procs.2017.06.036>

Zhang, P., Zhang, Q., Liu, F., Cao, N., Song, C., Li, J., Liu, Y., Yang, C., Higgs, R., O', G. M. P., Hare, N. A., & Xu, L. (2017). The construction of winter wheat smart water saving irrigation system based on big data and internet of things. *International Journal of High Performance Systems Architecture*, 7(3), 151. <https://doi.org/10.1504/IJHPSA.2017.091501>

Zhou, B., Lau, V., & Wang, X. (2020). Machine-Learning-Based Leakage-Event Identification for Smart Water Supply Systems. *IEEE Internet of Things Journal*, 7(3), 2277–2292. <https://doi.org/10.1109/JIOT.2019.2958920>

# APPENDICES

## Appendix A: Similarity Report

### Turnitin Originality Report

[Document Viewer](#)

Processed on: 17-Apr-2023 6:11 PM EAT  
ID: 2067285675  
Word Count: 15978  
Submitted: 1

JaniceMuringoGichuhiFinal.pdf By Janice Muringo Gichuhi

Similarity Index	Similarity by Source
24%	Internet Sources: 21%
	Publications: 12%
	Student Papers: 10%



## Appendix B: Strathmore University Institutional Ethics Review Committee Approval

Mrs Gichuhi Janice,  
janice.gichuhi@strathmore.edu

Dear Mrs Gichuhi,

### **RE: A Smart Water Management System for Detecting Household Water Wastage**


This is to inform you that SU-ISERC has reviewed and approved your above SU- master's research proposal. Your application reference number is SU-ISERC1678/23. The approval period is from 13<sup>th</sup> April 2023 to 12<sup>th</sup> April 2024.

This approval is subject to compliance with the following requirements:

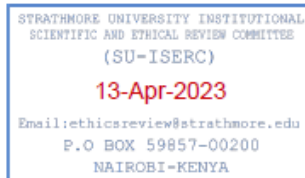
- i. Only approved documents including (informed consents, study instruments, and MTA) will be used
- ii. All changes including (amendments, deviations, and violations) are submitted for review and approval by SU-ISERC.
- iii. Death and life-threatening problems and serious adverse events or unexpected adverse events whether related or unrelated to the study must be reported to SU-ISERC within 48 hours of notification
- iv. Any changes, anticipated or otherwise, that may increase the risks or affect the safety or welfare of study participants and others or affect the integrity of the research must be reported to SU-ISERC within 48 hours
- v. Clearance for the export of biological specimens must be obtained from relevant institutions.
- vi. Submission of a request for renewal of approval at least 60 days prior to the expiry of the approval period. Attach a comprehensive progress report to support the renewal.
- vii. Submission of an executive summary report within 90 days of completion of the study to SU-ISERC.

Before commencing your study, you will be expected to obtain a research license from National Commission for Science, Technology, and Innovation (NACOSTI) <https://research-portal.nacosti.go.ke/> and obtain other clearances needed.

Yours sincerely,

  
for: **Dr Ben Ngoye,**  
**Secretary; SU-ISERC**

**Cc: Mr Ambrose Rachier,**  
**Chairperson; SU-ISERC**



## Appendix C: Application Libraries Used:

```
#include <ESP8266WiFi.h>
#include <BlynkSimpleEsp8266.h>
#include <ESP8266mDNS.h>
#include <WiFiUdp.h>
#include <ArduinoOTA.h>
```

