

# Charging in IP Multimedia Networks

Vitalis G. Oziyani<sup>§</sup>, Neco Ventura  
University of Cape Town,  
Department of Electrical Engineering  
{vitozy<sup>§</sup>, neco}@crg.ee.uct.ac.za

**Abstract**—IMS charging can be performed at various planes of the IMS architecture. Different charging schemes may be utilized. The optimal charging scheme would be service dependent, but may also be influenced by user expectations. The 3GPP has standardized charging mechanisms, protocols and interfaces for IMS charging control; online and offline charging have been standardized. However, the design and development of charging systems is operator dependent. This paper presents an IMS charging prototype developed and implemented in C, in line with Open IMS research. The testbed supports flow level, subsystem level and content level charging for IPTV and VoIP. The testbed supports online and offline charging; it has been tested with the UCT IMS client and the Fokus Open IMS system. Testbed proof of concept and performance results are presented.

**Index Terms**—Charging, IMS, IPTV, QoS, VoIP.

## I. INTRODUCTION

Development work on the IP Multimedia Subsystem (IMS) has been on going for a couple of years. Initial deployments by mobile and fixed line operators have been rolled out as well. IMS has experienced slower acceptance by operators, who cite lack of business models that are needed to sustain and improve income margins and Average Revenue Per User (ARPU). Charging is a function in the operator's network that facilitates the collection of revenue for resource usage. Thus processes involving charging, billing and accounting are the most critical operation and support processes for the telecommunications network.

A typical IMS session, e.g., VoIP session involves sending of an invite message by the caller's user agent (UA). The message traverses IMS core entities, i.e., the P-CSCF, I-CSCF, S-CSCF in the caller's domain and also the callee's domain. An exchange of SIP messages between the caller and callee UAs may occur to fulfil pre-conditions for session establishment. A normal termination of a VoIP session will involve sending of a *bye* message by one of the UAs. Interception of session establishment and termination messages by IMS entities may be done for the purpose of charging and billing. When IMS Application Servers (AS) are deployed in the network, redirection of SIP messages to the AS is done by the S-CSCF according to filter criterion defined at the HSS and downloaded to the S-CSCF upon user registration. IMS charging may be achieved by deploying a charging AS, which receives session messages re-directed by the S-CSCF.

As standardized by 3GPP, IMS charging involves the following main entities: a Charging Trigger Function (CTF), a Charging Data Function (CDF), and Online Charging Function (OCF). The CTF will be deployed as an intergral part of every AS or entity where charging information should be collected.

The CDF is used for offline charging processes, and involves exchange of Diameter accounting messages with the CTF across an Rf reference point. The OCF is required for online charging; the exchange of Diameter credit control messages with the CTF occurs across an Ro interface.

In IMS communications QoS provisioning and charging control are achieved according to the 3GPP TS 23.203 [1]. Charging control may be implemented at the service level, or the IP flow level or at both levels. The choice of the implementation scenario can depend on the traffic characteristics of different applications, and the enforced level of network performance guarantee. It may also depend on the media path used by the traffic. To achieve end-to-end communications between source and destination nodes, media traffic may traverse several intermediate networks. Accounting of resource usage in each network is necessary for charging and planning purposes. The accounting process consumes system resources, and network bandwidth is required to transport the accounting data to billing and processing systems.

Simpler charging schemes will consume less system resources, and are easy to understand. Moreover, they are more attractive to users. Volume and QoS based charging is more effective for multimedia communication networks. IMS communications involve the establishment of sessions using *invite* messages. The session description protocol (sdp) body of Session Initiation Protocol (SIP) *invite* messages can be used to carry QoS information, e.g., media codecs. The QoS information may influence charging decisions in the billing domain.

The provision of services like VoIP and IPTV utilizes media codecs that state bandwidth requirements; thus the media quality. Operators may enforce higher charging rates for higher quality media. Duration based charging may be used for VoIP and IPTV services. Strict identification of the start and end of charging sessions is required. Capturing of IMS charging trigger events, e.g., *invite*, *re-invite* and *bye* messages is key to the operation of the charging system. If volume of data accounting is required to give a measure of bandwidth usage by different sessions the PCEF in the media path would be involved in the charging process.

This paper presents a functional IMS charging prototype. The work presented includes the development of an Rf and Ro reference point for offline and online charging. The charging system utilizes a generic charging AS, a service specific AS with an intergral CTF; it also supports flow level charging at the PCEF. IPTV and VoIP are used as example services to illustrate charging features of the prototype. The rest of

the paper is structured as follows: section II reviews charging in the IMS as standardized by 3GPP; section III presents the design and operation of the IMS charging prototype; section IV presents the implementation architecture; section V presents testing and results of the prototype in a research lab; section VI concludes the paper.

## II. CHARGING STANDARDIZATION

IMS charging standards have been released by the 3GPP and IETF. When necessary 3GPP creates extensions to Internet protocols created by IETF to meet IMS requirements. 3GPP has defined a common charging framework for all IMS services and applications [2]. To cover all aspects of charging at different planes of IMS, there are additional specifications for flow level, sub-system level and service level charging. IMS supports online and offline charging. In online charging there is a real-time interaction between charging control mechanisms and resource consumption. On the other hand in offline charging there is no real-time interaction between charging control and resource consumption.

### A. Offline Charging

The entities involved in offline charging include: a CTF, CDF, charging gateway function (CGF) and a billing domain [2]. The CDF and CGF may often be integrated into one entity in the billing domain. The Rf reference point inter-connects the CTF and CDF. The CTF generates and sends Diameter Accounting Requests (ACR) to the CDF upon detection of chargeable events. A CTF may be integrated in the following IMS entities: I-CSCF, S-CSCF, P-CSCF, SIP AS etc. The ACR is sent in Diameter Attribute Value Pairs (AVP) of Diameter messages [3]. When the start of a charging session is detected, the CTF starts collecting charging events and transfers the collected information in *interim* ACR messages. At the termination of a charging session a final ACR will be sent to the CDF. Accounting Answer (ACA) messages would be sent by the CDF to the CTF in response to received ACR messages.

### B. Online Charging

The Diameter Credit Control protocol is used in online charging [4]. Credit control is required to pre-authorise sessions prior to commencement of resource consumption. Similar to offline charging, online charging requires a CTF. In addition an OCF is required; the OCF is part of the Online Charging System (OCS). For online charging the CTF may be integrated in the following IMS entities: MRCF, SIP AS and S-CSCF; an IMS gateway function is required to support credit control at the S-CSCF. Communication between the CTF and the OCF occurs across an Ro interface. The Ro interface supports Diameter credit control. When a chargeable event is detected a Credit Control Request (CCR) message is sent to the OCS. The tariffing function in the OCS will determine the value of the requested resources to enable allocation of credits for a specific amount of resources, e.g., duration of usage etc. The allocated credits will be sent to the CTF in a Diameter Credit Control Answer (CCA). In the case of resource consumption the account balance management

function performs supervision of credit usage in order to signal termination of service delivery if credits get exhausted [5].

### C. Session Based Charging

Session based charging is used when the expected resource usage cannot be determined upfront. It involves the generation of multiple charging events that are sent to the CDF or OCS. The start of a user session is detected at the CTF as a chargeable event that is mapped to a charging event. Unit reservation of credits is always performed for online session based charging. The reserved credits would correspond to the authorized number of minutes or bytes. Credit supervision is then performed during the lifetime of the session. Interim charging events will be issued to request more credits from the OCS, and a final charging event issued at session termination. Any unused quota will be credited to the user's account. For offline charging, charging events will be forwarded to the CDF at the start of the session; interim and final charging event will be sent during the course and at the end of the session respectively.

*Duration Charging:* Duration based charging has been used for circuit switched voice telephony for many years. Users have gotten accustomed to this scheme; the network basically charges for the use of a circuit of fixed capacity. The distance component that is considered in voice telephony does not exist in IP communications. Unlike flat-rate charging, the need for usage based pricing schemes relates to the popularity of real-time applications that require stricter QoS guarantees from the underlying network [6].

*Flow level Charging:* Flow level charging caters for volume based charging [1]. It may be used in conjunctions with congestion control mechanisms.

### D. Event Based Charging

Event based charging is used for single end-user-to-network transactions e.g., MMS or VoD request. For each transaction a chargeable event is detected at the CTF and a charging event is transferred to the relevant entity in the billing domain. In online charging, charging events are sent to the Event Based Charging Function in the OCS. Event based charging may be accomplished with unit reservation or immediate charging.

*Content Charging:* Content based charging is required by service and application providers. In IMS services and applications can be provided by deploying an application server. Application and content providers often outsource the process of charging these services to the network operator. The operators may thus provide a unified and converged billing platform to meet user needs. In addition to a single bill for communication services, users also require advice of charge and the ability to set service usage preferences.

### E. IMS Session Description

The session description protocol (SDP) is used to convey important information in SIP messages used for session establishment and control. SDP is an information representation format for describing multimedia sessions. Among the important lines in an SDP body are 'm=', 'b=' and 'a=' lines. The 'm=' lines carry information about the media type, e.g., audio or video and the codecs used; the 'b=' lines convey the

bandwidth information; the 'a=' lines are optional lines that provide more information about the media stream.

### III. IMS CHARGING PROTOTYPE

This section presents the design and development of a charging prototype for IMS services. The design is based on the Fokus Open IMS framework. The charging framework supports flow level, subsystem level and service level charging. The charging functions are deployed as a generic charging server for VoIP charging, and a CTF integrated in an IPTV application server. Another CTF is integrated into the PCEF to achieve flow level charging. The charging system has been tested with the UCT IMS client and the UCT advanced IPTV application server, which have been enhanced with functionality to achieve various charging aspects. Fig. 1 illustrates the layout of the charging system.

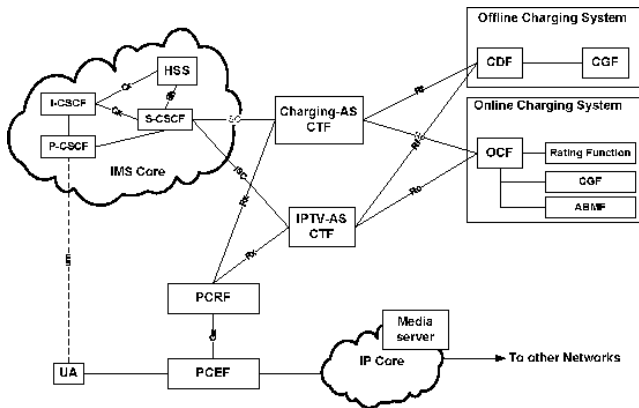

Fig. 1. The charging prototype

#### A. Charging Application Server

The charging application server uses a SIP proxy server to which all IMS sessions are re-directed. A CTF in the charging server captures all SIP *invite*, *re-invite* and *BYE* messages; these are the main chargeable events. Each of these messages is processed in order to extract details of the caller; e.g., SIP URI and realm. A charging ID is assigned to new sessions; the ID is used for all subsequent charging processes for the session. Each session is either subjected to offline or online charging.

Every new session is added to a list of active sessions to be processed sequentially once every pre-set time period elapses. Shorter processing intervals achieve finer charging granularity, but will result in a higher processing overhead. For offline charging an accounting request message is sent to the CDF across the Rf interface. The ACR contains information that is packaged in Diameter AVPs; the information includes the charging ID, subscriber identity, the nature of the chargeable event (initial, interim or final) and the identity of the charging application server. A Diameter credit control message is sent to the OCF in the case of online charging.

Interim chargeable events are invoked at the expiry of interim charging periods. The charging AS maps these events to interim charging events and sends them to the CDF or OCF. The duration of the interim period is a configuration parameter that can be set globally for all sessions. Shorter interim periods

will result in finer granularity but more Diameter messages will be exchanged between the charging AS and the billing domain.

In addition to the AVPs mentioned above, interim and final ACR and CCR messages contain credit values of resources consumed by a session in the elapsed period. Upon receiving initial and interim CCR messages the OCF performs credit control to allocate a limited amount of credits to authorise resource usage. The amount of authorised credits depends on the cost of service as determined by the rating function. The allocated credits are sent to the charging AS in Diameter CCA messages; CCA messages that are in response to interim requests will update unused credits at the AS. Credit supervision is invoked whenever interim requests are received; credits are allocated from the user's balance. Figure 2 illustrates account the balance management processes. If the user credit balance is exhausted the charging AS terminates the session by sending a BYE to all parties involved in the session.

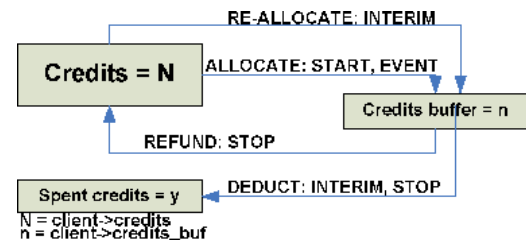

Fig. 2. Credit control functions

#### B. Flow Level Charging

The following entities are involved in flow level charging: an application server, the S-CSCF, the PCRF and the PCEF. The PCEF will perform traffic metering for charging purposes. It is located on the media plane; thus all media traffic will traverse it. Communication between the PCEF and PCRF occurs across the Gx interface. The PCRF creates policy and charging rules and installs them at the PCEF. Chargeable events e.g., the start of a VoIP session will be detected by the CTF in the application server. The application server communicates with the PCRF across the Rx interface. The information required to identify flows belonging to IMS sessions includes the media port numbers and IP addresses of the user agents; a charging ID assigned by the application server is also used. This information is contained in the SDP bodies of SIP invite messages.

The PCEF uses firewall rules to inspect packets and identify packets belonging to target flows. Mechanisms for achieving packet inspection are platform dependent. On the Linux platform packages like IP-tables may be used to achieve packet inspection and metering (IP accounting). The charging process at the PCEF involves counting bytes of data belonging to a flow and sending the charging information to the OCS across the Gy interface or the offline charging system (OFCS) across the Gz interface [7].

#### C. VoIP Charging

At the S-CSCF VoIP invite messages are re-directed to the charging application server. This is done according the initial

filter criteria (iFC) rules that are downloaded from the HSS whenever a user registers with the IMS domain. The iFC rules would be created at the HSS by an administrator. SIP messages defined to correspond to chargeable events are processed to retrieve information like VoIP codecs from SDP bodies.

Both online and offline charging are performed for VoIP. For online charging, the charging server acts as an IMS-GW connected to the S-CSCF via the ISC interface and implementing credit control towards the OCS. Duration based charging is performed at the charging server; timing would start at the reception of a 200ok for the *invite* message. Fig 3 illustrates the message flow for VoIP charging in the testbed.

To enforce volume charging for VoIP, session description information would be extracted at the charging AS and used to create a charging rule to be installed at the PCEF. The PCEF will forward flow level charging information to the OCS and the OFCS as discussed above.

#### D. IPTV Charging

The IPTV platform used in this work was developed by the Communications Research Group at the University of Cape Town. The IPTV AS is embedded with a CTF to detect chargeable events and send charging events to the CDF and OCS. Event based, duration based and flow level charging may be invoked for IPTV services. In this design event based charging is used for VoD services. Both offline and online charging are supported. Flow level charging can be used to account for the volume of IPTV traffic. Fig 4 illustrates the message flow for IPTV VoD charging. Duration charging is also supported by the IPTV AS.

#### E. Balance Enquiry and Advice of Charge

The UCT IMS client was enhanced to enable users to view their credit and debit balances; Advice of Charge (AoC) for services delivered to the user is also supported. Balance enquiry is handled as an event based chargeable event that causes the charging server to send an ACR or a CCR to the billing domain. The received ACA or CCA will contain the user's debit or credit balance.

AoC is accomplished through piggy backing credit usage information on SIP BYE or 200ok messages at the end of a session. During the parsing of received SIP messages, the client identifies message bodies that contain credit information and displays to the user.

### IV. IMPLEMENTATION AND TESTING

The charging prototype utilizes open source software released by the Fraunhofer Fokus institute in Germany as part of the Open Source IMS (OSIMS) project [8]. The testbed is implemented using the Linux (Ubuntu) operating system. Implementation of the Gx, Rx, Ro and Rf Diameter interfaces is based on the C Diameter Peer (cdp), also released by Fokus. Fig 5 illustrates the layout of the testbed.

The charging AS uses an oSIP library that implements a SIP server. When processing all IMS messages that are re-directed to it by the S-CSCF, the charging AS identifies SIP invites, re-invites and BYE messages. It derives a charging ID from the IMS call ID number and parses the message to extract the billing account type (pre-paid or post-paid) as selected by the

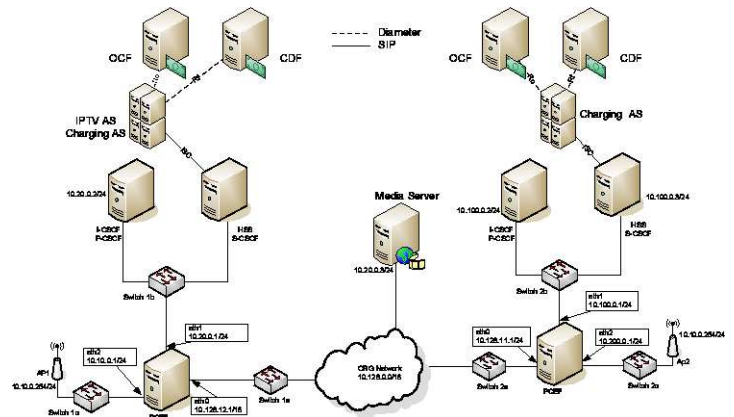

Fig. 5. IMS testbed layout with charging functions

user. Alternatively the user's billing account type would be retrieved from the user profile in the billing domain. Mysql C libraries are used to access the Mysql database.

The SIP server invokes charging with parameters that identify the subscriber, chargeable event, charging ID and the dialog ID. The Dialog ID would be used for charging related call control procedures, e.g., network initiated call termination due to credit exhaustion. To support multiple charging AS per billing domain, a CTF ID is assigned to each AS. The CTF ID is included in ACR and CCR messages sent to the CDF and OCS. For both offline and online charging the AS sends the first request to the billing domain before resource usage commences. This message reports a credit usage of zero for event based, duration based and flow level charging.

#### A. Flow Level Charging

Flow level charging is achieved through interactions between the charging AS and the PCEF. In this scenario the charging AS combines the roles of an AS and the PCRF. It invokes flow level charging by sending a Resource Authorization Request (RAR) to the PCEF containing attributes that identify the subscriber, charging ID, chargeable event, type of charging (online or offline), an interim period and media flow identification information. Once the attributes are packaged in Diameter AVPs the Diameter request is sent to the PCEF, where flow control and metering rules are installed.

In our initial implementation we use IPtables on Linux to create a filter for packets belonging to the flow for each session. Using Linux IP accounting, the byte counts for each filter are read in intervals specified by the interim period value received in the RAR from the PCRF (charging AS). The charging data is sent to the OCS or OFCS via the charging AS. For online charging the AS will perform credit control and quota supervision, and terminate flow level charging and service delivery if the user's credit balance is exhausted. When this happens or when a user terminates the session the charging AS sends a request to the PCEF to close the media flow gate and terminate charging.

#### B. Enhancements to the UCT IMS Client

To support user interaction with the charging system, the UCT IMS client was modified to convey and receive additional information. To enable selection of pre-paid or post-paid

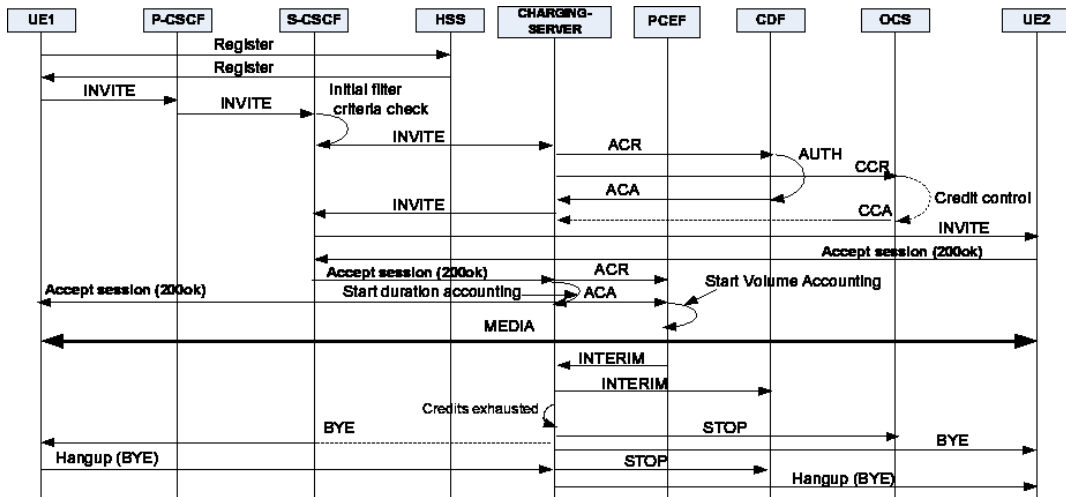

Fig. 3. Message flows for VoIP Charging

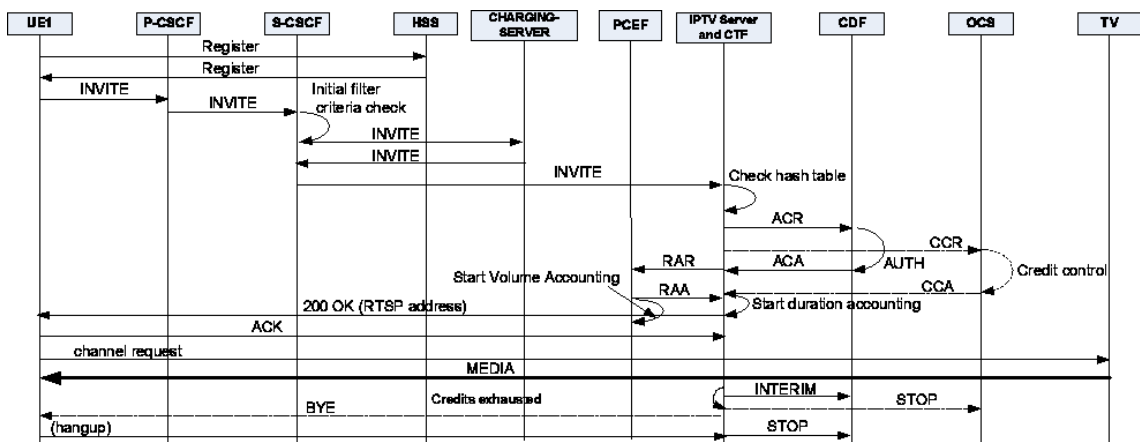

Fig. 4. Message flows for IPTV charging

billing, a charging profile page was added. Balance enquiries are also accessible via this page. Payment required error message (SIP code 402) has been added to support pre-paid billing operations.

C. Pre-paid and Post-paid Billing

A user’s account may be configured for pre-paid or post-paid billing. The account status is stored in the user profile in the billing domain. In the implementation we mapped pre-paid billing to online charging and post-paid billing to offline charging. Users may select usage of a pre-paid or post-paid billing account through an interface on the client. The selection is transported as optional information in the optional fields of SDP bodies of invite and BYE messages. The user’s billing account selection will be conveyed as ‘a=ct:0’ or ‘a=ct:1’, which corresponds to post-paid and pre-paid billing respectively. This information passes transparently through IMS entities that do not support or use it.

V. TESTS AND RESULTS

This section presents proof of concept tests conducted on the charging system. The tests illustrate the operation of the online charging system and flow level charging for VoIP. System

performance tests highlighting session setup delay incurred when charging functionality is added are also presented.

A. Proof of concept tests

The operation of online charging was observed and the credit control trend established. The interim report period was varied from 5 seconds to 30 seconds for duration charging. The number of Diameter CCR messages sent to the OCS was recorded and the credit allocation pattern by the OCS established. Fig. 6 depicts the credit control behavior with different interim periods.

Shorter interim periods result in more Diameter messages with smaller credit quotas. Flow level charging was performed for IPTV VoD services. Using an interim reporting period of 5 seconds the charging system depicted the pattern shown in Fig. 7. It is evident from the results that the charging system captures the data exchange between the VoD server. The video stream is a variable bit-rate data stream.

B. Performance Tests

To determine the effect of charging processes on session establishment delay several tests were performed for VoIP and

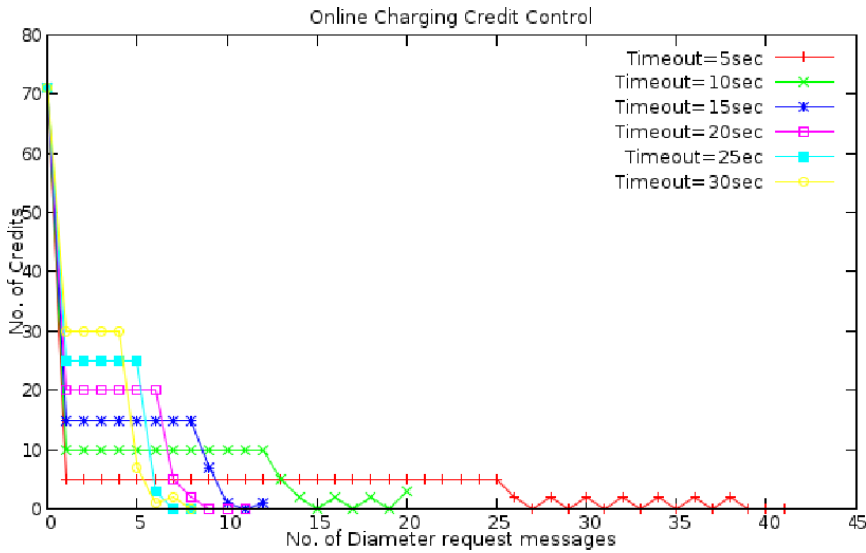

Fig. 6. Online charging credit control pattern

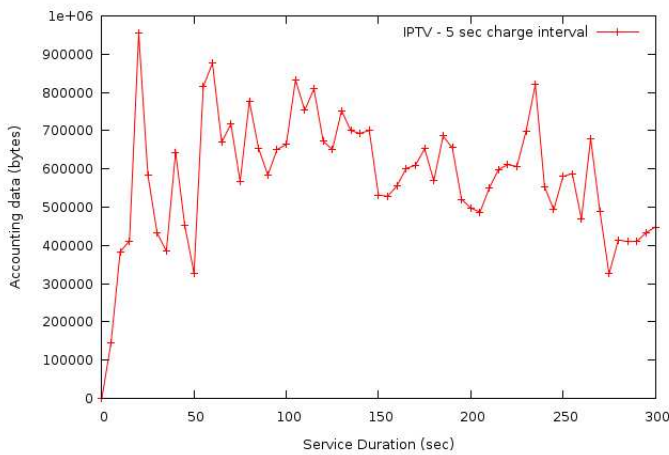

Fig. 7. Flow level charging for IPTV VoD services

IPTV. The results are depicted in Fig. 8, which shows that charging on average introduces little extra delay to session establishment. The additional delay is about 200ms; this value will not have a noticeable effect on user experience since it will not be perceived by the users.

## VI. CONCLUSIONS

In this paper we presented the design and implementation of a charging framework for IMS networks. The charging framework supports offline and online charging for VoIP and IPTV VoD services. The implementation created Diameter Rf and Ro reference points for communication between the charging AS and the billing domain entities. Duration based, event based and flow level charging are supported. Preliminary proof of concept and performance tests have been presented; however more tests would be performed as further development work involving the use of IP packet capture libraries are integrated into the PCEF. The charging system was developed in C and released as open source to allow for further development.

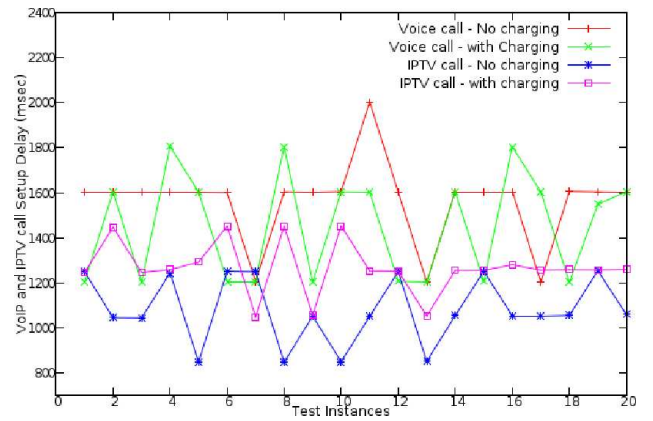

Fig. 8. Session setup delays for VoIP and IPTV with charging mechanisms

## REFERENCES

- [1] 3GPP, "Policy and Charging Control Architecture," *TS 23.203, 3rd Generation Partnership Project (3GPP)*, March 2009.
- [2] R. Kuhrie et. al, "Charging in the IP Multimedia Subsystem: A Tutorial," *IEEE Communications Magazine*, vol. 45, pp. 92–99, July 2007.
- [3] P. Calhoun et.al., "Diameter Base Protocol," *IETF RFC 3588*, Sept. 2003.
- [4] H. Hakala, "Diameter Credit Control Application," *IETF RFC 4006*, Aug. 2005.
- [5] 3GPP, "Charging Architecture and Principles," *TS 32.240, 3GPP*, Dec. 2008.
- [6] M. Koutsopoulou, A. Kaloxylos, A. Alonistioti, L. Merakos, and K. Kawamura, "Charging, accounting and billing management schemes in mobile telecommunication networks and the internet," *IEEE Commun. Surveys*, vol. 6, pp. 50–58, First Quarter 2004.
- [7] 3GPP, "Policy and Charging Control over the Gx reference point," *3GPP TS 29.212 rel. 8*, 2008.
- [8] P. Weik, D. Vingarzan, T. Magedanz, "The FOKUS Open IMS Core - A Global Reference Implementation," *The IMS Handbook: Concepts, Technologies and Services*, pp. 113–132, Nov. 2008.

## B iography

Vitalis Gavole Ozianyi (MSc) is a PhD candidate in the department of electrical engineering at the University of Cape Town. He attained a MSc in electrical engineering at the University of Cape Town in 2006. His research interests include charging and billing in communication networks.