



Strathmore
UNIVERSITY

Strathmore University
SU+ @ Strathmore
University Library

Electronic Theses and Dissertations

2017

A Smart-bin prototype for in-house waste management

Eric M. Mware
Faculty of Information Technology (FIT)
Strathmore University

Follow this and additional works at <https://su-plus.strathmore.edu/handle/11071/5659>

Recommended Citation

Mware, E. M. (2017). *A Smart-bin prototype for in-house waste management* (Thesis). Strathmore University. Retrieved from <http://su-plus.strathmore.edu/handle/11071/5659>

This Thesis - Open Access is brought to you for free and open access by DSpace @ Strathmore University. It has been accepted for inclusion in Electronic Theses and Dissertations by an authorized administrator of DSpace @ Strathmore University. For more information, please contact librarian@strathmore.edu

A Smart-Bin Prototype for In-House Waste Management

Mware M. Eric

Master of Science in Information Technology

2017

A Smart-Bin Prototype for In-House Waste Management

Mware M. Eric

A Research Thesis Submitted in Partial Fulfillment of the Requirements for the
Degree Of

Master of Science in Information Technology at Strathmore University

Faculty of Information Technology

Strathmore University,

Nairobi, Kenya

June, 2017

This thesis is available for Library use on the understanding that it is copyright material and that no quotation from the thesis may be published without proper acknowledgement.

Declaration

I declare that this work and has not been previously submitted and approved for the award of a degree by this or any other University. To the best of my knowledge and belief, the thesis contains no material previously published or written by another person except where due reference is made in the thesis itself.

© No part of this thesis may be reproduced without the permission of the author and Strathmore University

Eric M. Mware Name of Candidate

..... Signature

..... Date

Approval

The research thesis of Eric M. Mware was reviewed and approved by the following:

Dr. Vincent O. Omwenga,
Director Research and Postgraduate Programmes
Faculty of Information Technology,
Strathmore University

Dr. Joseph Orero,
Dean, Faculty of Information Technology,
Strathmore University

Professor Ruth Kiraka,
Dean, School of Graduate Studies,
Strathmore University

Acknowledgements

I would wish to first of all acknowledge the almighty God for the unmerited grace, favor, perfect health, strength and motivation during the entire process of preparing this piece of research.

Secondly, I would like to acknowledge my supervisor, Dr. Vincent Omwenga for his tireless mentorship, passion and motivation to see the accomplishment of this work. I would also like to thank Dr. Joseph Orero, our dean for the commitment and servitude.

I convey my sincere appreciation to my parents Mr. and Mrs. Joseph Mugo for believing in me, instilling courage from childhood and nurture the desire to pursue knowledge to this level. May God indeed bless you!

I would also like to thank the library staff in Strathmore University for their support. I wish to extend my gratitude to my colleagues Ambrose Ebale, Steve Obado, Judy Nyakairu, Anthony Mwangi, Lucas Ngoge, Mariam Heroe and Anthony Nganga for the collaboration and their positive influence during the research and pray that God will bless them in all of their endeavors.

Abstract

A healthy environment is imperative to a healthy and happy community. Clean and well monitored environments are a key need in human habitable environments. In-House management and monitoring of waste is a key aspect in achieving this. The existing system of using waste monitoring personnel to regularly check and empty filled dustbins, the process has been prone to delays or neglect. Additionally, due to different frequency of usage of dustbins in different areas, routine checks which are based on time crevices is inefficient because a dustbin might get filled early and may need immediate attention or there might not be any need of a routine check for a long period of time. This makes present system resource expensive and ineffectual, as overflowing, stinking dustbins become more of a problem than a solution. This study presents a solution about the Smart-Bin Prototype for In-House Waste Management which integrates the idea of IoT with Wireless Sensor Networks. Arduino ATmega328P Microcontroller is used to interface the sensor system and the IoT hub. Dustbins in an area are embedded with low power and low cost smart ultrasonic and gas sensors that are connected to an IoT device, which acts as a central hub for all bins. The bins transmit their gas content and its fill-level status to the central hub which relays this data to a cloud platform. The cloud platform further pushes the data to the client app a GUI (Web or mobile) in which the current gas content and their state (filled or not) is displayed. The client app GUI can be used by the waste management personnel and data can be used to plan their routine check. This timely garbage monitoring would optimize resources, reduce cases of neglect and is easy to adopt.

Table of Contents

A Smart-Bin Prototype for In-House Waste Management	i
A Smart-Bin Prototype for In-House Waste Management	ii
Declaration	iii
Approval	iii
Acknowledgements	iv
Abstract.....	v
List of Figures	x
List of Tables	xi
Abbreviations/ Acronyms.....	xii
Chapter 1: Introduction.....	1
1.1. Background of the study	1
1.2. Waste Management in Nairobi	3
1.3. Domestic and Corporate industrial waste collection.....	3
1.4. Problem Statement.....	4
1.5. Research Objectives	4
1.6. Research Questions.....	5
1.7. Justification	5
1.8. Scope	5
Chapter 2: Literature Review	7
2.1. Introduction	7
2.2. Elements of Waste Monitoring System.....	7
2.3. Waste Composition.....	7
2.4. Existing aspects for monitoring and evaluation.....	8
2.4.1. Weighing of waste.....	8
2.4.2. Waste composition analyses of dry recyclables, food and residual waste	9
2.4.3. Waste composition analyses of bulky waste, hazardous waste and WEEE	9
2.4.4. Indicators for evaluation	10
2.5. Integrated Technologies and Approaches.....	10
2.5.1. Wireless Sensor Network (WSN).....	10
2.5.2. ZigBee	11
2.5.3. GSM/GPRS.....	11
2.5.4. Radio Frequency Identification (RFID).....	12

2.5.5.	Geographic Information System (GIS).....	12
2.5.6.	Web Camera.....	13
2.6.	Existing Models/Solutions.....	13
2.6.1.	Automated Solid Waste Bin Monitoring System.....	13
2.6.2.	Smart Dustbin-An Efficient Garbage Monitoring System.....	14
2.6.3.	Smart and Wireless Waste Management.....	15
2.7.	Solid waste management challenges.....	16
2.8.	Conceptual Model.....	19
Chapter 3: Research Methodology		20
3.1.	Overview.....	20
3.2.	Research Design.....	20
3.2.1.	System Analysis and System Requirements	21
3.2.1.1.	Questionnaires.....	22
3.2.1.2.	Prototyping.....	22
3.2.1.	System Design	22
3.2.2.	System Implementation	23
3.3.	Target Population and sampling Frame.....	23
3.4.	Data Collection Methods.....	24
3.5.	Data Analysis.....	25
3.6.	Research Validity and Reliability.....	25
3.7.	Ethical Considerations.....	26
Chapter 4: System Analysis and Design.....		27
4.1.	Introduction.....	27
4.2.	Data Analysis and Findings.....	27
4.2.1.	Trash Bins monitoring ability.....	27
4.2.2.	Efficiency of Current bin Monitoring.....	28
4.2.3.	System Alerts Capability.....	28
4.2.4.	Reporting and dashboard capability.....	29
4.3.	System Requirements	30
4.3.1.	User Requirements.....	30
4.3.2.	Functional Requirements.....	30
4.3.3.	Non-Functional Requirements.....	31
4.4.	System Architecture.....	32
4.4.1.	Architecture Design.....	32

4.5.	Process workflow	33
4.6.	Use Case Modeling	33
4.7.	Sequence Diagrams.....	35
4.8.	Data and Process Modeling	36
4.9.	Class Diagrams.....	36
Chapter 5: Implementation and Testing		38
5.1.	Introduction	38
5.2.1.	Hardware Requirements.....	38
5.2.1.	Software Requirements	39
5.3.	Server Configurations.....	40
5.3.1.	Creating new Channel.....	40
5.3.2.	Dash boarding	41
5.4.	Sample Application Configuration Forms	42
5.4.1.	Adding the Sensors Channel	42
5.4.2.	Adding Components	42
5.4.3.	The Application Dashboard	43
5.5.	The Pseudo code.....	44
5.5.1.	Configuration Setup	44
5.5.2.	The main Execution	44
5.5.3.	PUSH to web API server	45
5.6.	Prototype Testing.....	46
Chapter 6: Discussions		48
6.1.	Introduction	48
6.2.	Findings.....	48
6.2.1.	User Interface.....	48
6.2.2.	Performance	49
6.2.3.	Convenience.....	50
6.2.4.	Reliability	50
6.3.	Limitations of the Prototype.....	51
Chapter 7: Conclusion and Recommendations.....		52
7.1.	Conclusions.....	52
7.2.	Recommendations for Future Work.....	52
Appendix A: Turnitin Similarity index.....		53
Appendix B: User Requirements Questionnaire		54

Appendix C: System Usability Questionnaire	57
Bibliography	59

List of Figures

Figure 2-1: Automated Solid Waste Bin Monitoring System Framework.....	14
Figure 2.2: Block Diagram for Smart Dustbin-An Efficient Garbage Monitoring System	15
Figure 2.3: Block diagram for Smart Garbage Bin.....	16
Figure 2.4: Conceptual model Diagram.....	19
Table 5.1: Hardware Requirements	38
Figure 6: Channels Menu	40
Figure 7: Channel Settings	41
Figure 8: System Dashboards	41
Figure 9: Mobile Application Configuration.....	42
Figure 10: Adding Components.....	43
Figure 11: Application Dashboard	43
Figure 12: Setup Pseudo code	44
Figure 13: Main program Pseudo Code.....	45

List of Tables

Table 1.1: Summary of wastes generation, collection and recovery status in major towns	2
Wealth status and consumer patterns significantly influence waste composition. A higher content of biodegradable and inert matter, results in high waste density (weight to volume ratio) and high moisture and gas content. <i>Table 2-1</i> shows an extract of household composition	7
Table 3: System Usability survey findings	48

Abbreviations/Acronyms

GIS	Geographic Information System
GPRS	General Packet Radio Service
GPS	Global Positioning System
GSM	Global System for Mobile communications
IEEE	Institute of Electrical and Electronics Engineers
IoT	Internet of Things
MSWM	Municipal Solid Waste Management
NEMA	National Environment Management Authority
RFID	Radio Frequency Identification
RX	Receive
SWA	Solid Waste Administration
SWM	Solid Waste Management
TX	Transmit
UART	Universal Asynchronous Receiver/Transmitter
WEEE	Waste Electrical and Electronics Equipment
WSN	Wireless Sensor Network

Chapter 1: Introduction

1.1. Background of the study

Solid waste which is one of the sources and causes of environmental pollution has been defined under Resource Conservation and Recovery Act as any solid, semi-solid liquid or contained gaseous materials discarded from industrial, commercial, mining or agricultural operations and from community activities (Bashir & Banday, 2013). Most daily human activities generate waste which requires to be properly managed to protect human health and environment while enhancing aesthetics. This scenario is particularly evident in urban settlements which generate large quantities of solid waste due to high human population (National Environment Management Authority, 2014).

Waste management is a task which occurs in a great variety of domains and contexts. Moderate amounts of waste can be found in any environment inhabited by human beings (Prassler, Stroulia, & Strobe, 1997). Waste management is an important requirement for ecologically sustainable development in many countries. Efficient management/ clearing of waste is a major issue in today's society (Glouche & Couderc, 2013). The impacts of poor solid waste management within the urban settlements, particularly cities and big municipalities can be disastrous (National Environment Management Authority, 2014).

Common methods of solid waste disposal is the use of waste bins for collection (Lazaro, Alexis, & Rubio, 2014). The office and domestic waste products are collected through waste bin at a common place at a particular spot. A major difficult task is the process of checking waste bins for the collection of waste (Bashir & Banday, 2013). The common waste collection process demands that waste management personnel has to pass by and collect waste from all the different waste bins. The waste management personnel has to present himself in person at all the waste collection points without the knowledge of the bin status. In this case, two possibilities present; either there is no waste for collection, or the bin has overflowed.

This is a complex and time consuming process. Rising waste disposal costs and high visibility of waste collection operations are forcing residents to demand efficient collection and disposal of solid waste (Dugdhe, Shelar, Jire, & Apte, 2016). As such there is need for proper and efficient waste management (Bashir & Banday, 2013). Cleaning of garbage bin in time will ensure proper cleanliness of the surrounding (Thakker, 2015)

Solid waste collection is one of the most expensive services provided by a city to its residents. Between 75-80% of the solid waste management budget is spent on collection and transfer costs. Therefore, productivity of collection and transfer operations is of significant concern (Dugdhe et al., 2016). Table 1.1 presents a summary of generation of waste in various Major towns in Kenya:

Table 1.1: Summary of wastes generation, collection and recovery status in major towns (adapted from National Environment Management Authority, 2014)

	Estimated Waste generated (tones/day)	% Waste collected	% waste Recovery	Uncollected waste
Nairobi	2400	80%	45%	20%
Nakuru	250	45 %	18%	37%
Kisumu	400	20%	Unknown	Unknown
Thika	140	60%	30%	40%
Mombasa	2200	65%	40%	35%
Eldoret	600	55%	15%	45%

Urban/suburban waste management involves numerous waste bins that exhibit significant filling variations (over days and seasons or location) and diverse requirements for emptying, from sporadic (a few times within a week) to very frequent (several times a day). On the other hand other waste forms (i.e. agricultural, biomedical, chemical, electronic, mineral, organic/inorganic, and radioactive, etc.)

are characterized by varying levels of gas emissions which are crucial for monitoring (Karadimas, Papalambrou, Gialelis, & Koubias, 2016).

The problem of efficient waste management is one of the major problems of the modern times, thus there is an utmost need to address this problem (Bashir & Banday, 2013) (Dugdhe et al., 2016). The proper waste management system is a must for the hygienic society in general and for a better world as a whole.

In order to protect human health and the environment from the potential hazards of delayed waste disposal and environmental pollution a systematically supervised and controlled handling of these wastes is of essence (Bashir & Banday, 2013).

The work proposed in this study illustrates how the Litter-Bin solution empowers cleaning operators to monitor in-house waste bins in real time. Thus, the system is able to help in increasing overall productivity and cleanliness.

1.2. Waste Management in Nairobi

Solid wastes in Nairobi are a by-product of a broad spectrum of industrial, service and manufacturing processes. Primary high-volume generators of industrial solid wastes include the chemical, petroleum, metals, paper, leather, textile, wood and transportation industries. Secondary smaller generators include auto and equipment repair shops, electroplaters, construction firms, dry cleaners and pesticide applicators. Mismanagement of these wastes typically results in pollution of the natural environment and may pose substantial danger to public health and welfare.

1.3. Domestic and Corporate industrial waste collection

Domestic waste is also referred to as garbage, refuse or in-house waste. It consists mainly of biodegradable waste which is food and kitchen waste, green waste paper and non-biodegradable such as plastics, glass bottles, cans, metals and wrapping materials. The composition of the domestic waste streams is a function of income, consumption patterns and recycling opportunities. Nationally domestic waste is not

adequately managed and is disposed at disposal sites with minimal sorting/segregation (National Environment Management Authority, 2014)

1.4. Problem Statement

Litter bins are emptied at certain intervals by cleaners. This method has several drawbacks such as: Some litter bins fill up much faster than the rate of emptying and they are full before the next scheduled time for collection. This leads to overflowing of rubbish bin and poses hygiene risks. Also there are special periods (e.g. festivals, during office activities, and active company/office periods) when certain litter bins fill up very quickly and there is a need for increased collection intervals (Folianto, Low, & Yeow, 2015). Additionally, some waste bins produce uncomfortable smell composed of toxic gases which poses a health hazard to human habitation. A lot of research has been done on different aspect of solid waste management, but a few works have been done on in-house bin monitoring (Dugdhe et al., 2016).

This research proposes a prototype solution that empowers waste monitoring personnel to timely collection of waste by notifying when the fill-level or safe gas emission levels are surpassed. The proposed solution is able to help in increasing overall productivity by ensuring collections occur only when needed, over-filling is eliminated, collection costs are reduced and residents enjoy an eco-friendly waste monitoring solution.

1.5. Research Objectives

The main objective of the study is to develop a smart-bin management and monitoring prototype to proactively detect fill-level or gas emission levels and notify the relevant waste monitoring personnel. The following specific objectives have been formulated:

- i. To **Identify** Elements relating to bin status monitoring.
- ii. To **Review** the approaches used in in-house waste monitoring systems.
- iii. To **Develop** a robust prototype to detect when litter bins fill up or generate toxic gases and notify the relevant waste monitoring personnel for collection.

iv. To Test the prototype.

1.6. Research Questions

- i. What are the elements used for waste bin status monitoring?
- ii. What are the approaches used in in-house waste bin monitoring systems?
- iii. How can a prototype for detecting litter-bins filling up or generating foul smell and notifying relevant parties be developed?
- iv. How reliable is the prototype developed?

1.7. Justification

This study helps to identify the gaps in monitoring of in house waste bins. The study aims at developing a prototype to benefit the domestic household and corporate user to be able to monitor the gas emission levels, and the fill levels from the waste bins.

The results of the study might propel the usage of the proposed prototype for detecting fill-level and gas emission level from waste bins and informing the waste monitoring personnel hence ensuring a safer, cleaner environment for all.

The research would also be important to scholars, as an addition to the existing body of knowledge also complementing the previous research carried out on the same. It will provide a fair platform for further research to be carried out on the adoption of waste bin monitoring systems.

1.8. Scope

The study is aimed at formulating a prototype for the adoption of waste bin monitoring systems. This is because such a solution may go a long way in enhancing accountability, proactive responsiveness and better management of waste, thus ensuring a safer, cleaner environment for everyone. This study was carried out in 2017.

The target of this study is the domestic household and corporate user. The prototype developed from this study will empower the domestic and corporate user

to be able to monitor the household bin status (gas emission levels, and the fill levels) over a period of time, being able to send notifications when bins require to be attended and reports on average household waste reporting.

Chapter 2: Literature Review

2.1. Introduction

This section presents a review of literature on waste monitoring in order to identify the variables to consider in household waste monitoring systems, identify gaps in existing literature develop theoretical and conceptual frame work and lay a foundation for empirical analysis. The result of the study from the information will be used to provide additional value or reference of the research which will be used for the conducted research and developing the prototype.

2.2. Elements of Waste Monitoring System

A typical waste monitoring system in a low or middle-income country can be described by the below elements (Zurbrügg, 2003):

- i. Household waste generation and storage.
- ii. Reuse and recycling on household level (includes animal feed and composting).
- iii. Primary waste collection and transport to transfer station or community bin.
- iv. Management of the transfer station or community bin.
- v. Secondary collection and transport to the waste disposal site
- vi. Waste disposal in landfills

The handling and storage of waste usually is the main element of the systems and is done by the household originators (Bashir & Banday, 2013). It is the way these waste is handled, stored, collected and disposed of, which can pose environment and public health risks (Zurbrügg, 2003). Where intense human activities concentrate appropriate, timely and safe solid waste management (SWM) are of utmost importance to allow healthy living conditions for the population.

2.3. Waste Composition

Wealth status and consumer patterns significantly influence waste composition. A higher content of biodegradable and inert matter, results in high

waste density (weight to volume ratio) and high moisture and gas content. *Table 2-1* shows an extract of household composition

Table 2.1: Waste characterization at immediate source and at communal collection points for Residential generators

(Kasozi & Von Blottnitz, 2010)

Waste Type	Composition (%)	
	At immediate Source (directly from Households)	At Communal Waste Collection Points located in Residential areas
Organic/Biodegradable	58.6	46.1
Paper	11.9	8.9
Plastics	15.9	15.4
Glass	1.9	5.6
Metal	2.0	2.3
Other	9.7	21.7
TOTALS	100%	100%

These physical characteristics significantly influence the feasibility of certain collection options. Systems operating with low-density wastes such as in industrialized countries will not be suitable or reliable under such conditions. Additionally to the extra weight, abrasiveness of the inert matter such as sand and metals, and the corrosiveness caused by the high water content, may cause rapid deterioration of the waste matter.

2.4. Existing aspects for monitoring and evaluation

2.4.1. Weighing of waste

A weight scale is installed in the waste collection vehicle in order to record the weight of all dry waste collected. A tag with a unique code is placed on each waste bin and waste from each recycling bin was recorded separately. Weights were registered on every occasion that the bins were emptied during the study period.

Importantly, the weight of the collection bin itself is subtracted from the result. In cases where tags were missing or weights not recorded for other reasons, a default weight was calculated based on other waste containers from the same fraction and collection date. The default weight is sometimes used for further calculation of the waste disposal intensity of the study area.

2.4.2. Waste composition analyses of dry recyclables, food and residual waste

Analyses are conducted on four occasions to investigate possible seasonal changes in waste generation and composition. Samples used for waste composition analyses were collected from three different recycling sites. All waste deposited in bins for dry recyclables and food waste and half of the vessels for residual waste (randomly selected) are analyzed. This approach is recommended by the SWA tool (Olsson, Lymberis, & Whitehouse, 2004) and the method is described in detail by (Dahlén & Lagerkvist, 2008). Consequently, errors related to sub-sampling were eliminated for dry recyclables and food waste and strongly reduced in the case of residual waste. Source-separated hazardous waste, WEEE, batteries and bulky waste are not considered in these analyses.

The same method of waste composition analysis was used on all four occasions. It is based on (Battese, 1995) and developed in co-operation with Lulea University of Technology

2.4.3. Waste composition analyses of bulky waste, hazardous waste and WEEE

In the case of bulky waste (including bulky WEEE, metal and other bulky waste disposed of in mobile containers), source-separated WEEE and source-separated hazardous waste, the total weight delivered to the waste treatment facility is recorded. The weight of all non-source-separated bulky waste dumped in the area and collected by facility managers was also recorded.

2.4.4. Indicators for evaluation

Four indicators were used to evaluate the current waste disposal system at the study site. All parameters were calculated on a wet weight basis.

The specific waste generation (kg household per year) was determined based on a weekly average derived from 104 weeks weighing of waste. Data are presented as a total and for all source-separated fractions and residual waste. The source-sorting ratio (weight-%) defined as the weight of collected source-sorted recyclable material in relation to the sum of the same material – sorted, incorrectly sorted and unsorted. Ratio of miss-sorted waste (weight-%), defined as the mass of non-packaging, non-newspaper and non-food waste deposited in bins designated for the same fractions, in relation to the total amount of disposed waste in each particular fraction.

Ratio of source-separated similar materials (weight-%), defined as the mass of non-packaging materials made from plastic, metal and paper (e.g. plastic sieves, metal bookstands and books not covered by the Producer Responsibility Ordinance or included in the source-separation instructions distributed to households regarding food waste) disposed of in bins designated for dry recyclables, in relation to the total amount of miss-sorted waste in the particular fraction.

2.5. Integrated Technologies and Approaches

2.5.1. Wireless Sensor Network (WSN)

A wireless sensor network is designated as a network of spatially distributed and devoted sensor nodes that cooperatively sense and record the physical conditions of the target area or object and disseminate the collected data to a base station. It can control the target object or environment by facilitating interaction between persons or computers and the area of interest. The sensor node contains radio transceiver, microcontroller, sensor board, and energy source, usually a battery. The main constraints that must be addressed when designing a WSN are the node's energy consumption, computational speed rate, bandwidth, and memory. Though, WSNs were primarily designed to assist military operations, since the start of the third

Millennium its application has been extended to different areas which creates a growing interest from industrial and research perspectives. In the last few years WSN is used in a huge number of applications like habitat monitoring, building automation, smart energy, health care, water and air quality monitoring, construction health monitoring, agriculture and food industry, fire detection etc (M. A. Al Mamun, Hannan, Islam, Hussain, & Basri, 2015).

2.5.2. ZigBee

ZigBee is an open standard that operates based on the IEEE 802.15.4 specification and offer the network infrastructure required for wireless sensor network (M. A. Al Mamun, Hannan, Hussain, & Basri, 2013). ZigBee outlines the network and application layers of the protocol stack where 802.15.4 specify the physical and MAC layers. ZigBee has a very low duty cycle and very long primary battery life. It supports static and dynamic star and mesh networks and more than 65,000 nodes, with low latency available. The ZigBee is enhanced to build ZigBee PRO feature set that support low power consumption and large area networks (M. A. Al Mamun et al., 2015)

2.5.3. GSM/GPRS

Global System for Mobile communications (GSM) is a standard for cellular communications developed by European Telecommunications Standards Institute. GSM offers voice telephony as its main service in which voice is encoded digitally and carried by the GSM network as a digital stream in a circuit-switched mode (Islam, Arebey, Hannan, & Basri, 2012). It also offers data services which allowed a maximum bit rate of 14.4 kbit/s and a channel is allocated to a single user for the period of the connection in circuit-switched mode. To overcome the limitations of data service, General Packet Radio Service (GPRS) is introduced which works in packet switching techniques. GPRS is developed from the existing GSM system and can be associated with the internet (A. Al Mamun, Hannan, & Hussain, 2013). GPRS facilitates the users to share the network resource to several time slots simultaneously and offers a bit rate of 170kbit/s. It also offers volume based

charging to users as pay as you use (M. A. Al Mamun et al., 2015). It provides a link between mobile users and data network and provides high-speed wireless IP or X.25 services for users. GPRS uses packet switching technology and each user can take up a number of wireless channels at the same time. The same wireless channel can be shared by multiple users and then resources can be effectively used. Using GPRS technology to send and receive data packets, users can be always on line. GPRS network has a wide coverage and can truly achieve ubiquitous, real-time communication (Islam et al., 2012).

2.5.4. Radio Frequency Identification (RFID)

The RFID is an available technology since the early 1900's and was utilized during World War II. The technology uses a few simple components. The RFID tag is composed of an antenna, integrated circuit, a reader that gathers information from the ID tag, and a database system that is used to store the information gained through interrogating the ID tag. Based upon the application, the identification tag can be active or passive. RFID is designed to enable readers to capture data from tags and transmit it to a computer system without any physical connection at a range of radio frequency. The antenna uses radio frequency waves to transmit a signal that activates the transponder. RFID is getting more attention across different industries. RFID technology is used in a wide range of applications worldwide including automotive, contactless payments, laundry, library, livestock, pharmaceutical, retail supply chain management, ticketing and in industry as an alternative to the bar code (Islam et al., 2012).

2.5.5. Geographic Information System (GIS)

A Geographic Information System (GIS) integrates hardware, software, and data for capturing, managing, analyzing, and displaying all forms of geographically referenced information (Maguire, 1991). GIS allows us to view, understand, question, interpret, and visualize data in many ways that reveal relationships, patterns, and trends in the form of maps, globes, reports, and charts. A GIS helps you answer questions and solve problems by looking at your data in a way that is

quickly understood and easily shared (Islam et al., 2012; Khan & Samadder, 2014). GIS technology can be integrated into any enterprise information system framework. GIS is used to location identification of a monitoring system by mapping out the location and movement in the form of geographic map (Chalkias & Lasaridi, 2009)

2.5.6. Web Camera

A webcam is a digital camera designed to take digital photographs and transmit them over the internet (Poh, McDuff, & Picard, 2011). The camera connects to computer and takes a snapshot image that gets saved to computer's hard drive. Webcam software allows controlling how often the camera takes a photo and updates (sends) that photo on web server (Islam et al., 2012).

2.6. Existing Models/Solutions

2.6.1. Automated Solid Waste Bin Monitoring System

The designed system uses wireless sensor networks integrating two different communication technologies. A set of sensors have been used to measure the bin status. The system can respond in real time which can help to develop an efficient solid waste monitoring system to reduce the operational cost and pollutant emission as well as can keep the environment green and safe (M. A. Al Mamun et al., 2015).

A sensor node is installed in a 240L waste bin. Wasmote from Libelium has been chosen as sensor nodes. In this mote, ATmega1281 microcontroller is used and it consumes 15mA power in active mode and 55uA power in sleep mode. It also contains a built-in accelerometer sensor. XBee-ZB-PRO RF module from Digi has been used as the radio transceivers which conform to ZigBee-PRO v2007 standard. ZigBee-PRO make best use of all the capabilities of the ZigBee feature set which is built on the top of the IEEE 802.15.4 functionalities and it enables support for larger networks encompassed of thousands of nodes. For the sensor set, the ultrasonic XL-MaxSonar- WRA1 (MB7070) from Maxbotix is used to measure the waste filling level, the AMS Load Cell resistance sensor form Hanyu is used to measure the weight of waste inside the bin, PLA41201 hall effect sensor is used to track the state

of the bin cover and to measure the temperature and humidity MCP9700A and 808H5V5 sensors is used accordingly. To integrate the sensors in the mote, the Smart Metering v2.0 board from Libelium is used. See figure 2.1.

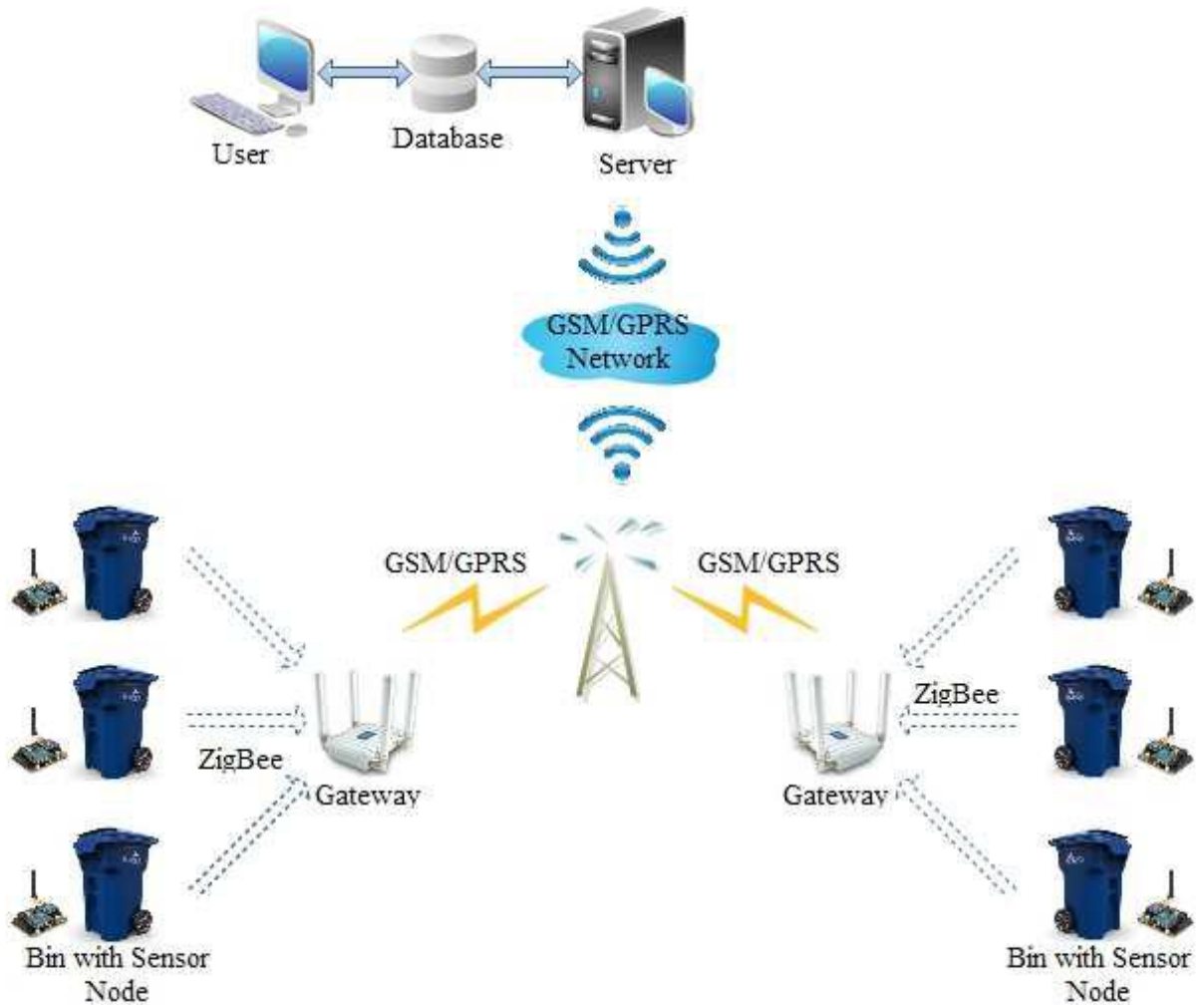

Figure 2.1: Automated Solid Waste Bin Monitoring System Framework

2.6.2. Smart Dustbin-An Efficient Garbage Monitoring System

In this study, GSM 900A modem is used to send the messages. It consists of a GSM/GPRS modem with standard communication interfaces like RS-232 (Serial Port), USB, so that it can be easily connected to the other devices. The ultrasonic sensor is used to find the height of garbage filled at different intervals of time. However, three sensors can be employed at various heights like $h/3$, $2h/3$ and h ,

where h is the height of the bin but to make it affordable and to achieve the same results, only one sensor is placed at surface level. Arduino Uno board is used as microcontroller platform. Interfacing is done between GSM modem and Arduino board by connecting RX pin of modem to TX pin of board and vice versa. ECHO and TRIGGER pins of sensor is connected to digital pins 5 and 13 of Arduino board. Arduino board works at 5V power supply and GSM modem requires 2A to power on. The threshold height is set to 10cm. Threshold distance is the difference in height at which sensor is placed and the level of garbage fill. During the course of garbage accumulation, whenever the difference falls below threshold value, GSM modem is activated to send an alert signal to the concerned authority through an SMS (Monika, Rao, Prapulla, & Shobha, 2016). Fig 2.2 represents a block diagram of the architecture

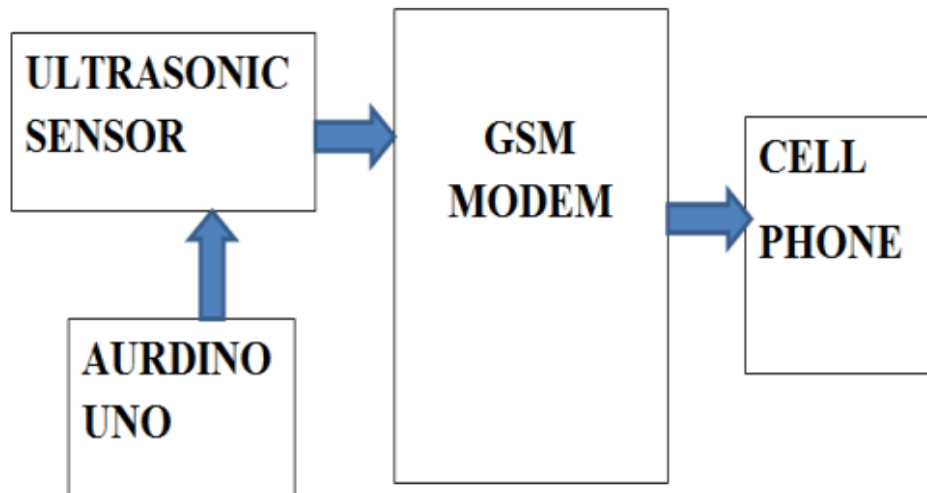

Figure 2.2: Block Diagram for Smart Dustbin-An Efficient Garbage Monitoring System (Monika et al., 2016)

The shortcoming of this system is that, there is no provision for smart monitoring of the bins status from a centralized system for proper monitoring. Secondly, the solution only caters for monitoring one aspect of the bin status, being fill-level only. There is a need for monitoring other aspects including the weight and Gas emission levels.

2.6.3. Smart and Wireless Waste Management

A set of three ultrasonic sensors as level sensor are installed at top portion of the bin. Along with it there will be load cells for pressure measurement purpose. Ultrasonic sensors will be interfaced with ultrasonic signal conditioning chip. Whereas the signal from array of 4 load cells will be given to Analog to Digital Converter. A GPS module will be installed outside the bin. Microcontroller will receive inputs. It will perform signal processing as per signal processing algorithms. With the help of an electronic switch and timing circuit in microcontroller the voltage of battery of sensors will be controlled. Microcontroller will communicate to GSM modem through UART. GSM modem will send the SMS to the municipality head office. So they will get SMS before their periodic interval visit of picking up dustbin. Fig.2.3 illustrates the systems block diagram architecture

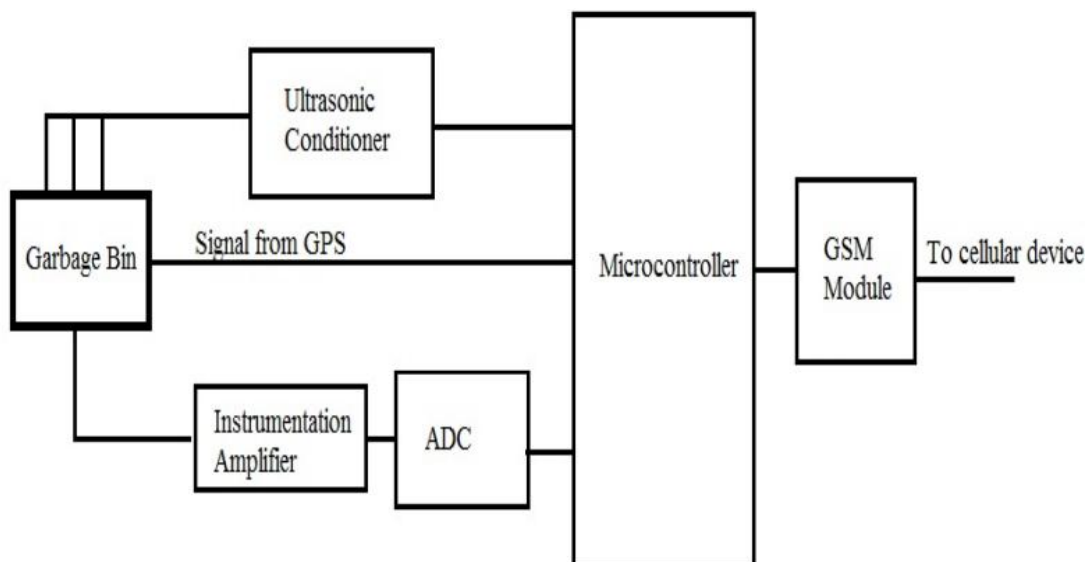

Figure 2.3: Block diagram for Smart Garbage Bin

2.7. Solid waste management challenges

The urban councils are responsible for the implementation of these instruments including ordinances and bye-laws. Environmental policymaking remains largely a function of the central government, but implementation of policies and legislation is devolved to the Local Governments (Liyala 2011; Oberlin2011; Okot-Okumu & Nyenje 2011; Tukahirwa 2011).

The existing laws on waste management are not being effectively enforced (Liyala 2011; Oberlin 2011; Okot-Okumu & Nyenje 2011; Simon 2007), which may be

attributed to inherent weaknesses of the laws themselves. The informal sector and the community therefore operate with little or no regulation at all.

Waste management is poorly financed because it is not a prioritised activity in all urban councils. Funds for the operation of the urban councils are mainly from external sources (over 50 %) like the central government and donors in the form of grants (Liyala, 2011). This means fiscal autonomy has not been realised by the EAC urban councils as observed by Okot-Okumu & Nyenje (2011).

Households not served by waste collection have developed their own waste management systems. The most common household waste management methods identified are waste burning and backyard burying or indiscriminate open dumping (Liyala 2011; Oberlin, 2011; Okot-Okumu & Nyenje 2011; Simon, 2007). Waste composting is still small-scale and insignificant, often by households and mostly for individual household gardens, while

Composting, which is technically viable, to be strongly vulnerable to external factors (Oberlin & Sza'nto', 2011). In East Africa these innovative methods for waste management remain un-researched denying interested individuals among the urban communities information on such projects.

Little investment has been made in MSWM research, resources and human capacity development. The only coordinated major research that has been done on waste management in EA cities is the one under PROVIDE where some of the MSc and PhD research results have already been published (Liyala 2011; Oberlin 2011; Simon 2007) .

Even though urban councils contract private operators to collect wastes, the urban councils themselves are still the main waste collectors and the combined efforts of the urban councils with the private sector have not yielded the levels of success expected. This is evident by the common scenes of uncollected wastes on roadsides and in drainage channels, streams and wetlands in urban and peri-urban areas.

The problem of MSWM in East Africa is compounded by the rapid urban population growth caused by rural to urban migration overstressing resources. The rising urban population and increasing industrial activities means larger volumes of wastes that pose threat to public health and the environment since they are predominantly decomposable organic and E-wastes are also increasing in the waste stream. Zurbrugg (1999) noted that the problems of MSWM are of immediate importance in many urban areas of the developing world and waste management is known as one of the key issues in urban management aside from water and sanitation. Municipal wastes therefore constitute one of the most crucial health and environmental problem of African urban councils (Achankeng 2003; Adebilu & Okekunle 1989; Asomani-Boateng & Haight 1999; Kaseva & Mbuligwe 2005). It is evident from Kaseva & Mbuligwe (2005) for Tanzania, Rotich et al., (2006) for Kenya and Okot-Okumu & Nyenje (2011) for Uganda that urban areas in East Africa have been experiencing serious solid waste management failures.

The prevailing attitude of the public towards waste collection and disposal or treatment is poor (Liyala 2011; Oberlin 2011). The urban communities generally do not participate in waste management responsibly.

The combination of all these factors together with the urban council weaknesses that cause management failures have led to the accumulation of wastes in neighborhoods leading to environmental degradation and threat of disease epidemics such as cholera, diarrhea and parasites. Socio-cultural and attitude problems in waste management may be addressed gradually through public education to sensitize the communities, while economic issues can be addressed by providing livelihood opportunities (employment) within the waste management activities.

2.8. Conceptual Model

The prototype consists of an Arduino ATmega328P Microcontroller used to interface the sensor system and the Azure cloud. Dustbins in an area are embedded with low power and low cost smart ultrasonic and gas sensors that are connected to the cloud, which acts as a central hub for all bins. The bins transmit their gas content and its fill-level status to the central cloud platform. The cloud platform further pushes the data to the client app a GUI (Web or mobile) in which the current gas content and their state (filled or not) is displayed. Database maintained at the central server can be used to generate the monthly or yearly reports regarding amount of waste collected in a week, month or year. This data can be used for management purposes. This prototype is aimed at ensuring collections occur only when needed, Over-filling is eliminated, reduced collection costs, reduced harmful gas levels and residents enjoy a friendly waste management service. Figure 2.4 illustrates the conceptual design.

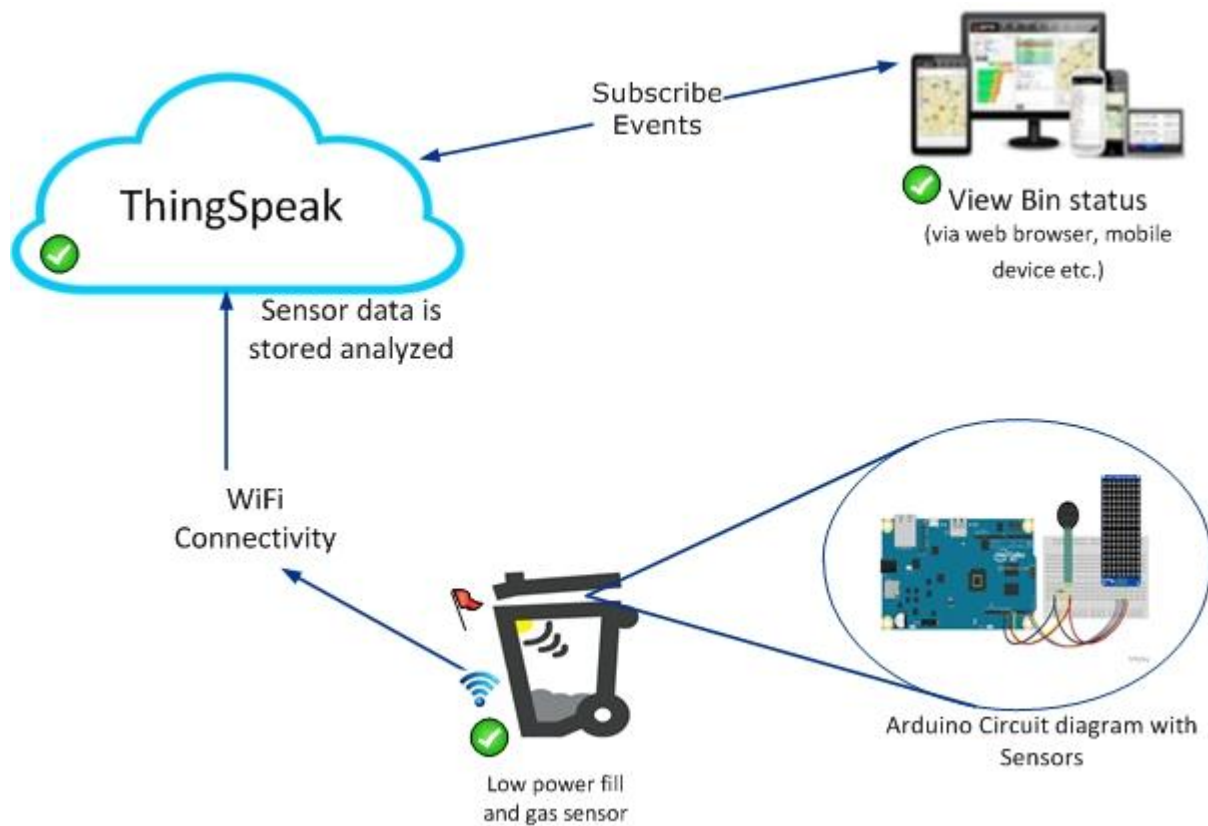

Figure 2.4: Conceptual model Diagram

Chapter 3: Research Methodology

3.1. Overview

This chapter covers the methodical framework used in the study. The research design is guided by the proposed objectives of the research outlined in chapter 1, the nature of the problem to be studied, and research designs used in prior, related research work reviewed in chapter 2. The chapter justifies the research framework and the method. It focusses at the research design, the population targeted, sample size, sampling techniques, types of data, data collection techniques, data analysis and test design.

3.2. Research Design

(Yin, 2003) defines research design as the logical sequence that connects the empirical data to a study's initial research questions and ultimately to its conclusions. It is a plan that guides the researcher in the process of collecting, analyzing and interpreting observations. According to (Hevner, March, Park, & Ram, 2004) a traditional research design is a blue print or a plan on how a research study is to be completed; operationalization variables to facilitate measurement; selecting a sample of interest to study; collecting data to be used as a basis for testing hypotheses; analyzing the results. This research study uses Semi-experimental research design with a quasi-experiment research study used to estimate the causal impact of an intervention on its target population without random assignment

This research proposes to develop a Smart-Bin Prototype that will accept sensor values data as input, and use the analysis in the derived model in order to detect the Fill-level, and gas emission levels of in-house waste bins. In order to do this a formal experimental design, specifically the true experimental design is adopted. True experimental design is characterized by the random selection of participants and the random assignment of the participants to groups in the study. The researcher also has complete control over the extraneous variables (Cobb, Confrey, DiSessa, Lehrer,

& Schauble, 2003). It can be confidently determined that the effect on the dependent variable is directly due to the manipulation of the independent variable.

3.2.1. System Analysis and System Requirements

This study employs Rapid application development (RAD) methodology, a software development methodology for iterative development and rapid development of prototypes rather than large amounts of up-front planning (Larman, 2004). Since the researcher aimed at providing quick results, rapid application development gave excellent development processes with the assistance of other development approaches (Abrahamsson, Warsta, Siponen, & Ronkainen, 2003). The lack of extensive pre-planning allowed the software to be written much faster, and made it easier to change requirements as illustrated on figure 3.1.



Figure 3.1: Rapid Application Development

Rapid application development process started with development of preliminary data models and business process models in the Requirements Planning stage using structured techniques. Requirements were then verified by designing and prototyping, to eventually refine the data and the process models. These stages were repeated iteratively; further development results in combination of the business requirements, technical design statement and Testing were used for constructing the prototyped systems.

The study also employed a multiple technique methodology of obtaining requirements from possible clients. The requirements elicitation process was achieved by administering Questionnaires and building of prototypes. This combination enabled the researcher acquire a complete picture from the diverse sets of clients and stakeholders.

3.2.1.1. Questionnaires

The Requirements elicitation questionnaires were much more informal, and were a great tool to gather requirements from stakeholders in remote locations or those who will have only minor input into the overall requirements. The questionnaires were very vital since the researcher gathered information from hundreds of users thus easing reach to the large masses and provided fast response through sharing by mail, Facebook, WhatsApp, Skype and other social platforms.

3.2.1.2. Prototyping

Prototyping is a relatively modern technique for gathering requirements. In this approach, the study gathered preliminary requirements that were used to build an initial version of the solution – the prototype. This was later shown to the client, who would then give additional requirements. The application would then undergo the application changes and cycle around with the client again. This repetitive process continued until the product met the critical mass of business needs.

3.2.1. System Design

The Smart Bin System design was achieved basing on the collected User requirements, and a detailed analysis of the existing methods of bin monitoring. These Requirements and the results of the analysis were synthesized to come up with a structured system design of the proposed prototype.

The Structured system design was employed and its aim was to obtain a blueprint of the system being developed. In this stage the study employed use of workflow diagram, use case diagrams, sequence diagram, Data Flow diagrams and Class Diagrams. The Hardware components include arduino shield, sensors and a wireless module for data communication. The development was done on a windows environment using the arduino IDE employing C++ language of development.

3.2.2. System Implementation

This phase allowed the logical and hardware development of the system whereby the systems specifications developed are turned into a working system prototype. It involved converting the developed designs to actual system functionalities whereby the workflow diagram, use case diagrams, sequence diagram, Data Flow diagrams and Class Diagrams are used as inputs to the implementation phase.

In this phase, we employed several software development tools. The arduino IDE was used as the Development environment, the ThingSpeak cloud resource was used as the web API interface for communication between the terminal nodes (sensors) of the system with the end user device through the application logic code running in the arduino microcontroller module. Also, the virtuino mobile application was used for end user aggregation setup and dash boarding interface.

On completion of Implementation, it was important to perform tests to ensure the end product produced matches the business user requirements gathered and is working logically as expected. The study employed both Developmental tests to confirm the program logic works as expected and Beta testing to verify proper working in an ideal environment with real data.

3.3. Target Population and sampling Frame

The study population comprised of households within Nairobi County Kenya and its neighboring counties. As at December 2009, the total population for Nairobi, Kiambu, Machakos and Kajiado counties stood at 1,892,224 households (KNBS, 2010).

This study employed convenience non probability sampling method due to the limited cash and time constraints. Convenience sampling is described as a random selection of sampling units within the segment of the population with the most information on the characteristic of interest. It is a sampling technique in which researcher relies on own judgment when choosing members of population to participate in the study. It is a non-probability sampling method and it occurs when

elements selected for the sample are chosen by the judgment of the researcher. Convenience sampling works best in this study as it obtains a representative sample by using a sound judgment, which resulting in saving time and money. To obtain the sample size, the below Eq 3.1 sampling without replacement formula was used

$$n = \frac{N}{1 + N(e)^2}$$

Equation 3.1:

e = 10%, N =1,892,224 and we thus obtain n to be 100

Where:

n is the sample size

N is the population size

E is the margin of error

3.4. Data Collection Methods

This study employs both Primary and secondary sources of data collection techniques. Primary data collection is used from the sensor data collected to the IoT cloud infrastructure, and the secondary data was obtained questionnaires served to the identified sample.

Questionnaires were chosen as the best instruments for this study as they provide an economical and convenient approach for data collection. This was necessary due to the time limitations. Questionnaires also provide anonymity of the respondents, and since the responses are gathered in a given standardized way, questionnaires provided a more objective approach. The respondents of this study were a total of 96 household representatives

Additionally to primary data, the research proposes to also collect secondary data from previous research, much of the data collected in Chapter 2 of this study.

The Requirements analysis questionnaire was conducted to identify the missing functionality of the currents methods of bin monitoring and aid us formulate new requirements. Thus aiding the research answer the objective (i). The System

Usability questionnaire on the other hand helped us achieve the Developmental and Beta testing methodologies employed in the study.

3.5. Data Analysis

In order to analyze the collected data and guarantee consistency and completeness, the research employed the use of Google Docs and Microsoft excels Spreadsheets for quantitative data analysis. The completed questionnaires and data gathered from personal interviews were first encoded in an analyzable format, and then analyzed, and lastly presented in a tabulated and summarized way using tables, bar graphs and pie charts. These methodologies provided suitable presentable designs for a general feel of the outcomes.

3.6. Research Validity and Reliability

The researcher ensured research validity by ensuring that the data collected from the survey respondents was relevant to the study. Also, Validity was ensured by subjecting the questionnaires to experts, with the guidance of the university supervisor.

From the study, both qualitative and quantitative data collected led to better requirements specification for the prototype development and development iterations of the work that led to the final design meeting the desired outcomes. The usability survey helped achieve a good measure of how the requirements were met by the designed prototype.

Surveys were conducted by extending the forms randomly to circle of friends and cohorts within the researcher's network. This employed the random selection without replacement. This method ensured some form of non-repetition when selecting respondents. The Google forms used allowed setting permissions and identifying who can complete the form. Meaning, researcher designate specific IDs to complete the form with the use of a survey ID, for example. This is done by creating an expression in the responses spreadsheet. Once you've identified people you want to fill out your form, you can create an identification column.

3.7. Ethical Considerations

To ensure ethical standards were upheld in this study, the researcher obtained consent from the participants obtained from the selected sample before the survey. The information and data obtained from the study was treated with a very high degree of confidentiality, and solely used for the purposes of this research study only.

Chapter 4: System Analysis and Design

4.1. Introduction

This chapter covers the system design and architecture based on the requirements specifications identified from the analysis of the data collected. It defines the stakeholders of the system, the system components, the system data models and system process models. The chapter also reviews the database design and provides an illustration of the interface wireframes of the system.

4.2. Data Analysis and Findings

In order to extensively obtain the System requirements, Questionnaires were administered to the general population consisting of households within Nairobi, Machakos, Kiambu and Kajiado Counties.

4.2.1. Trash Bins monitoring ability

As illustrated in figure 4.1 below, 27% of the sample size responded that it was extremely hard for household users to be able to detect pungent smell and fill ups of in-house trash bins. Additional 21% said that it was Hard, 25% were neutral, 9% said it was easy and another 18% responded that it was extremely easy.

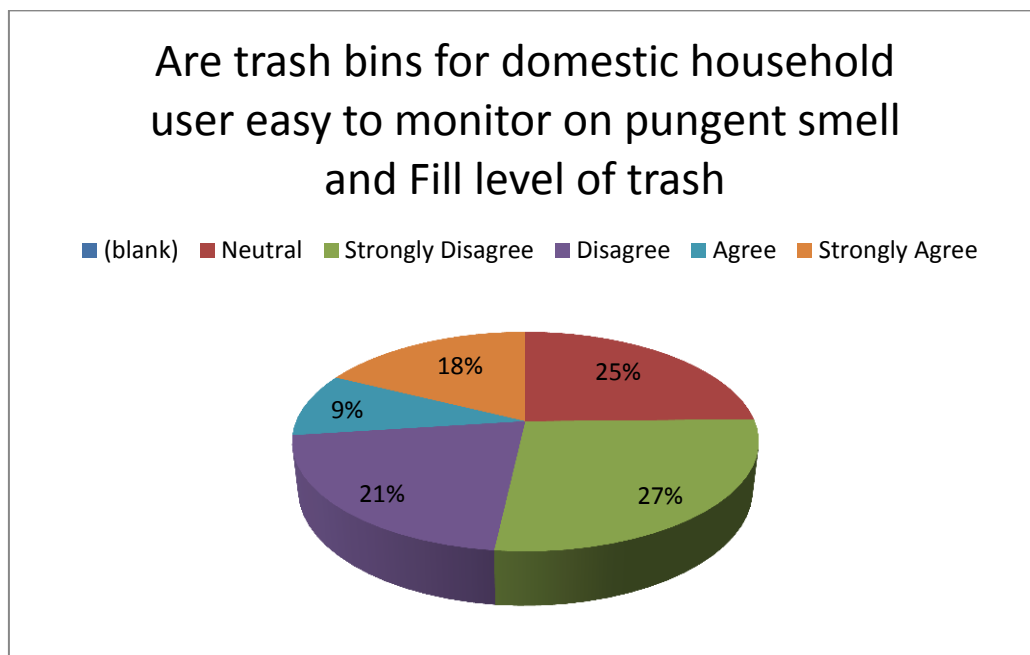

Figure 4.1: Ease of monitoring Bin Status

4.2.2. Efficiency of Current bin Monitoring

The Survey as from figure 4.2 indicated that 31% Majority of the sample responded that the Current method is not efficient. An additional 12% stated that it was extremely in-efficient. 19% of the population was neutral, 31% responded that it was effective and 8% that it was extremely efficient.

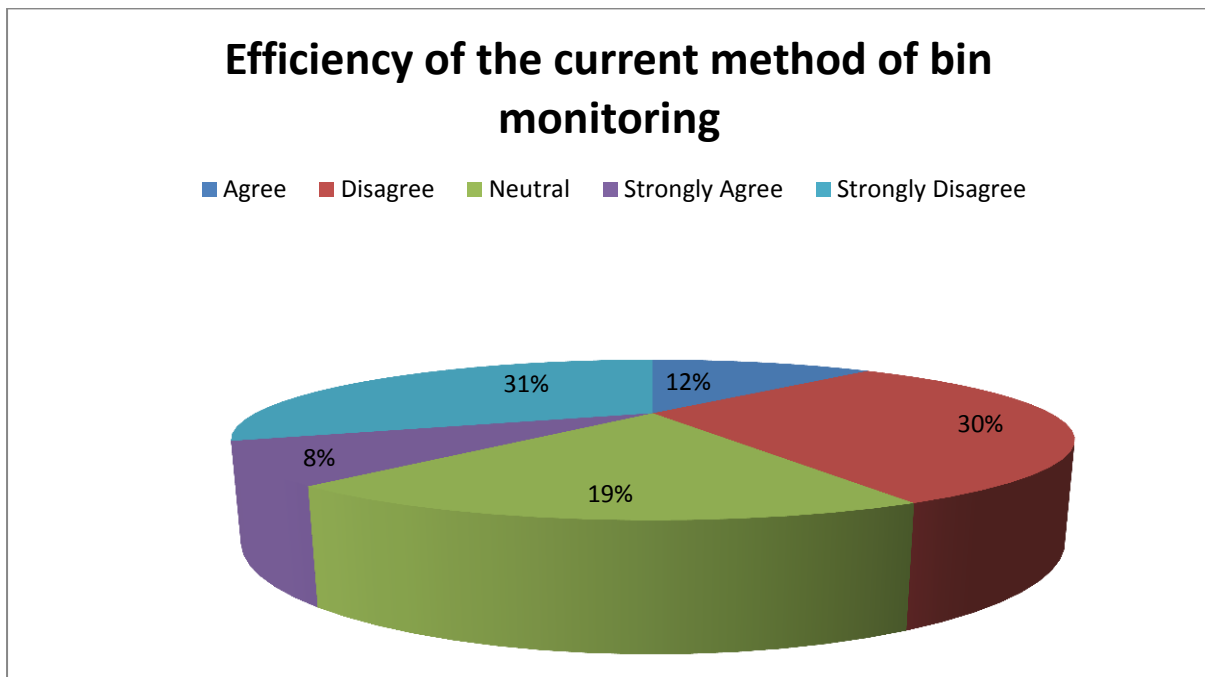

Figure 4.2: Efficiency of current Bin Monitoring

4.2.3. System Alerts Capability

From the Efficiency survey, the greater majority of 57% responded that the current system is completely incapable of alerting users in case bin emits gas or is filling up. An additional 12% stated the current method is incapable, 7% of the sample were neutral, 12% responded that it is capable and another 12% stated that it is highly capable. See results from table 4.3

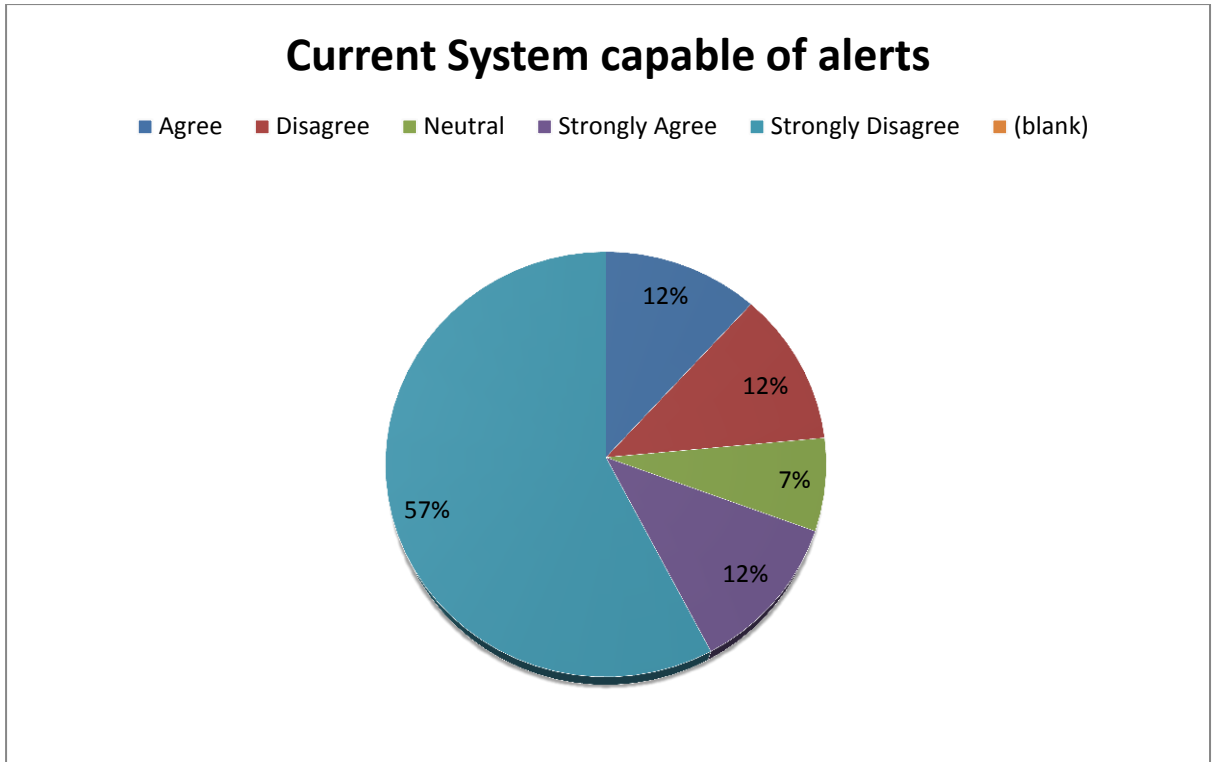

Figure 4.3: Capability of alerts

4.2.4. Reporting and dashboard capability

As from the results on figure 4.4, 61% of the sample strongly disagreed that the current methods have reporting capabilities. An additional 19% also disagreed. 7% were neutral, 7% agreed and 6% strongly agreed on this capability.

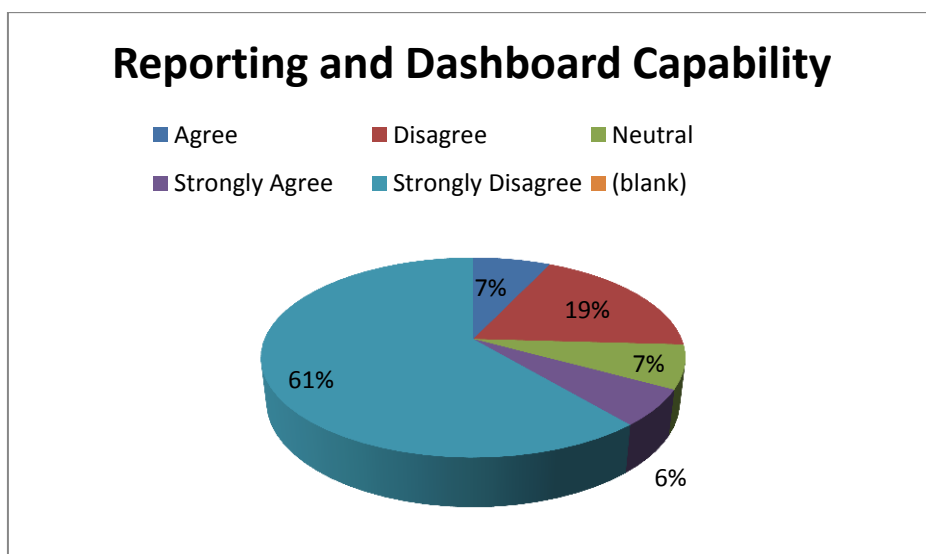

Figure 4.4: Reporting and Dashboard Capability

4.3. System Requirements

From the User requirements study carried out in this study, the researcher was able to identify the gaps and user needs that formed the basis for the below identified user and system requirements

4.3.1. User Requirements

- I. A system that would be able to monitor on Gas emission, and Fill level in the shortest time possible.
- II. A system that would notify or present this information to the relevant people.
- III. A user friendly and interactive system.
- IV. A secure system with access restrictions and privacy.
- V. A system that can provide historical usage reporting.

Several functional, non-functional and technical requirements emerged from the analysis of data obtained in this research study. These requirements informed the architectural design and the various components crucial for the Smart-Bin solution to solve the research problem.

4.3.2. Functional Requirements

These are the core system requirements the system must fulfill in order to be regarded as having solved the research problem. They include:

i. Setting optimal fill level

This allows for the system user/operator to specify the fill level they consider optimal, after which exceeding this limit will result in notifications/ alerts for collection

ii. Set optimal gas-content level

This allows for the system user/operator to specify the gas content level they consider optimal, after which exceeding this limit will result in notifications/ alerts for collection

iii. Check bin status

This allows the user to view at any time, the gas, fill-level of the monitored bin via a web or mobile phone browser.

iv. Notifications

This feature will allow the home user to be able to be notified whenever the fill-level or gas content level surpasses the stated optimal levels.

v. Reporting

This feature allows the system to generate reports when required.

4.3.3. Non-Functional Requirements

Non-functional requirements include constraints and qualities. The qualities are properties or characteristics of the system that its stakeholders care about and hence will affect their degree of satisfaction with the system (Malan & Bredemeyer, 2001). The non-functional requirements include:

i. Security

This aspect refers to the act of providing trust of the information, that the Confidentiality, Integrity and Availability of the information are not violated, e.g. ensuring that data is not lost when critical issues arise. It ensures that only the allowed user is allowed access to view edit and download bin status reports and data. The online server will only allow administrative users with authorized credentials to log in and view all the configurations and reports of the system

ii. User Support

This offers a help section where a user can learn more on how to use the system. It also offers instant notifications to the users to make them aware of significant events taking place in the system.

4.4. System Architecture

The System Architecture can be presented in three main tiers; Presentation layer, application layer and the data layer. The presentation layer presents data to the user. In the figure 4.1, the mobile application and the web browser client interfaces presents this layer. The application layer performs the application logic. It provides a link by which the clients in the presentation layer are able to access data in the data layer. It consists of the cloud based server and the code running in the arduino microcontroller.

4.4.1. Architecture Design

The system consists of three main components; a cloud based server setup, Arduino ATmega328P Microcontroller used to interface the sensor system and the Azure cloud. Dustbins in an area are embedded with low power and low cost smart ultrasonic and gas sensors that are connected to the cloud, which acts as a central hub for all bins. The bins transmit their gas content and its fill-level status to the central cloud platform. The cloud platform further pushes the data to the client app a GUI (Web or mobile) in which the current gas content and their state (filled or not) is displayed. Database maintained at the central server can be used to generate the monthly or yearly reports regarding amount of waste collected in a week, month or year. This data can be used for management purposes. See fig 4.5 for the architectural diagram

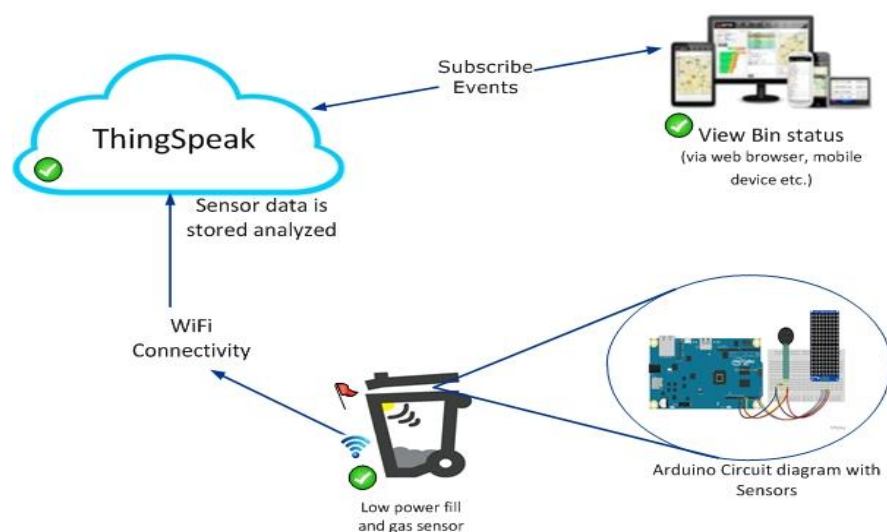

Figure 4.5: Architecture Diagram

4.5. Process workflow

The workflow design depicts the flow of data and information through the system. It caters for the logical developer design options and defines actions of given decisions and information process flows. Figure 4.6 illustrates the design achieved from the requirements of this research.

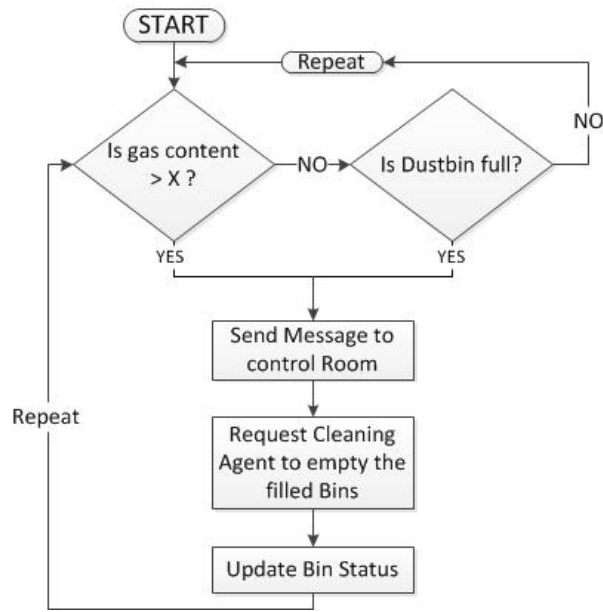

Figure 4.6: Process Workflow

4.6. Use Case Modeling

Figure 4.7 illustrates a smart bin use case diagram used to offer a visual representation of the various roles of the system and how they interact with the various functions of the system. It illustrates the activities performed by the users of the System that is the functional requirements from a user's perspective.

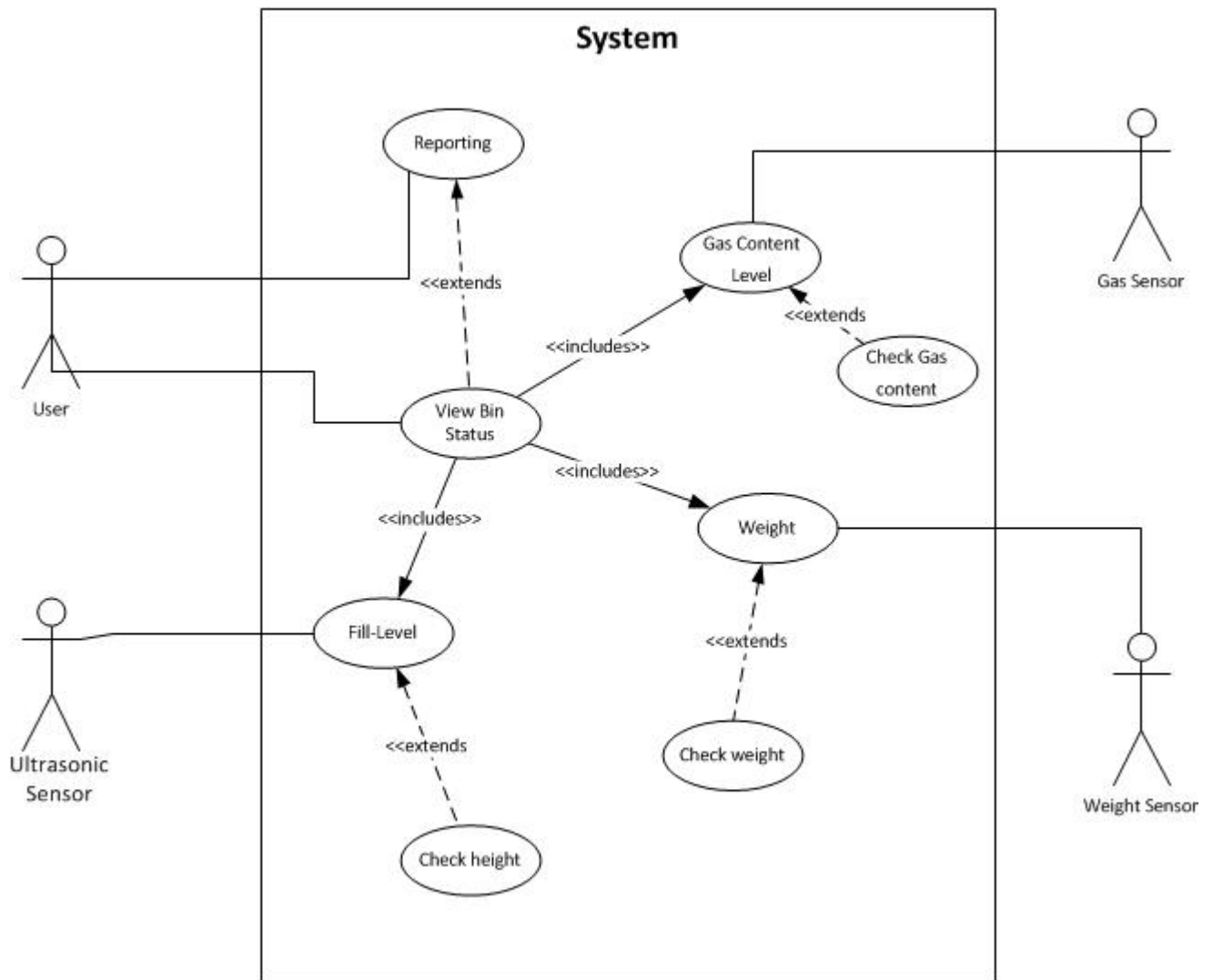

Figure 4.7: Use Case Diagram

4.7. Sequence Diagrams

The sequence diagram in fig 4.8 depicts how objects interact with each other via sending and receiving of messages and responses in the execution of a use case or operation. The user has to register then login to be able to interact with the System. On successful installation and login, the user could prompt the System to display the bin status from a web browser or a mobile browser. This request will prompt actions to check the gas level, and the fill level of the bin and transmit the values through the arduino microcontroller to the user's browser on his device.

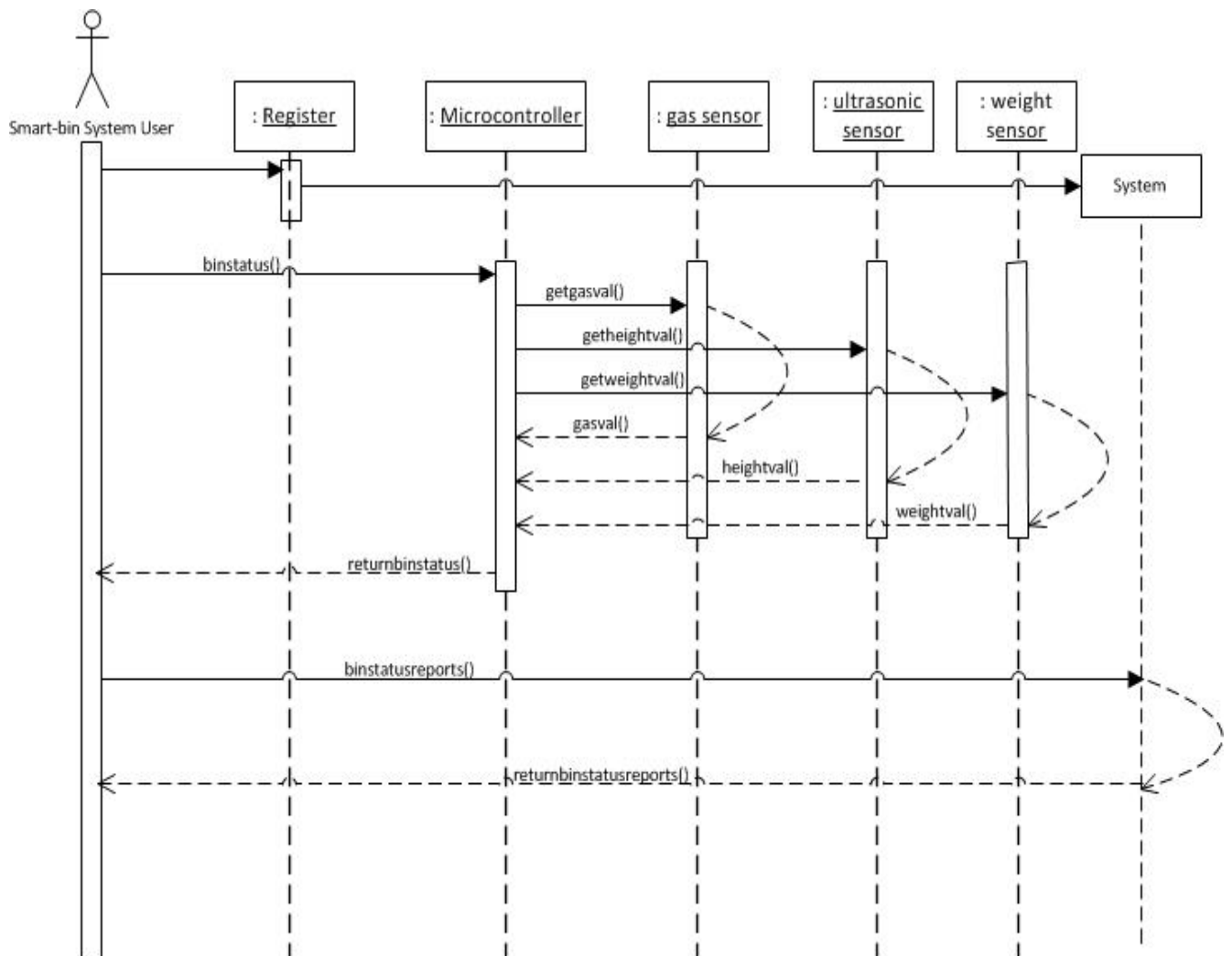

Figure 4.8: Sequence Diagram

4.8. Data and Process Modeling

A Data Flow Diagram (DFD) depicts the flow of data and relationships between different components of a system. They show the high level details and how data inputs are transformed to data outputs via functional transformations. They show the functions required to run in a program and the data these functions need (Le Vie, 2000). Figure 4.9 describes in detail the system Data Flow Diagram

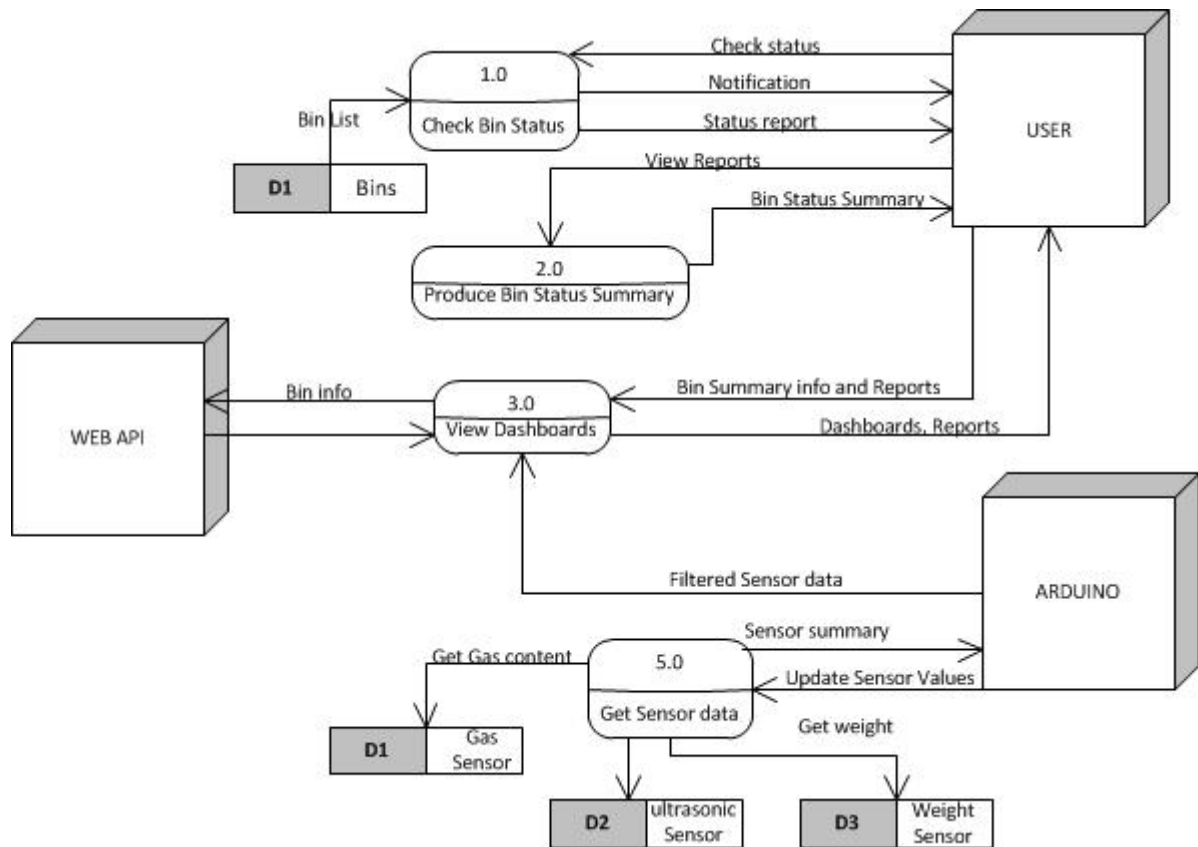

Figure 4.9: Data Flow Diagram

4.9. Class Diagrams

These are representations that are used to show hierarchical relationships as shown on figure 4.10 below. A class diagram is also used to show other relationships like whole/part 'has a' relationship using aggregation and composite connectors, interaction 'uses' relationships with dependency arrows, or associations with connecting lines.

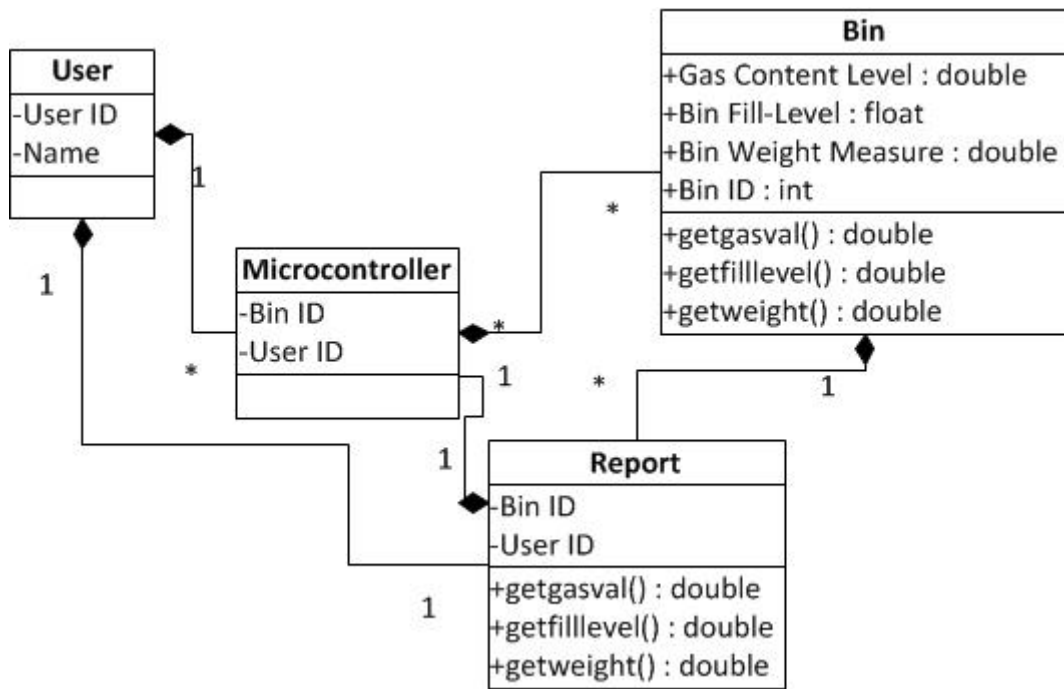

Figure 4.10: Smart-Bin Prototype Class Diagram

Chapter 5: Implementation and Testing

5.1. Introduction

This chapter describes the implementation and evaluation process conducted on the Smart Bin system. In terms of implementation, the development environment, tools, development platform, database used and levels of system users are also discussed. Meanwhile for testing, the type of testing procedure used, participants and analysis made on the results for the testing procedure are explained

5.2. Development Environment

The Suitable development environment is established to ensure that the implementation process runs smoothly. The following describes the software and hardware requirements for the development process:

5.2.1. Hardware Requirements

Table 5.1 describes the hardware requirements of the Smart Bin system.

Table 5.1: Hardware Requirements

Hardware	Description
Arduino uno Board	Arduino Uno microcontroller board (ATmega328). It has 14 digital input/output pins (of which 6 can be used as PWM outputs), 6 analog inputs, a 16 MHz crystal oscillator, a USB connection, a power jack, an ICSP header, and a reset button.
ESP8266 Wireless Module	The ESP8266 Wi-Fi Module SOC with integrated TCP/IP protocol stack. Features: 1MB flash disk size, 802.11 b/g/n, Wi-Fi Direct (P2P), soft-AP, Integrated TCP/IP protocol stack, Integrated TR switch, balun, LNA, power amplifier and matching network, Integrated PLLs, regulators, DCXO and power management units, +19.5dBm output power in 802.11b mode, Power down leakage current of <10uA 1MB Flash Memory, Integrated low power 32-bit CPU could be used as application processor, SDIO 1.1 / 2.0, SPI, UART, STBC, 1×1 MIMO, 2×1

	MIMO, A-MPDU & A-MSDU aggregation & 0.4ms guard interval, Wake up and transmit packets in < 2ms, Standby power consumption of < 1.0mW (DTIM3)
A 3.3V power Source	3.3V power Source for powering The ESP8266 Wi-Fi Module SOC
A Solder less PCB Breadboard	Model: MB-102 Dimension: 165mm x 55mm x 10mm, Tie Points: 830 Tie Points consists of: 630 Tie-Point Terminal Strip, 200 Tie-Point Distribution Strips, Matrix: 126 separate 5 point terminals, plus 4 horizontal bus lines (Power Lines) of 50 test points each, Wire size: Suitable for 29-20 AWG wires
Jumper Wires	20cm, wire cable connectors from dupont. Male to Female, Female to Female and Male to Male terminated.
HC-SR04 ULTRASONIC SENSOR	The HC-SR04 ultrasonic sensor uses sonar to determine distance to an object like bats or dolphins do. It offers excellent range accuracy and stable readings Features: Power Supply :5V DC, Quiescent Current : <2mA, Effectual Angle: <15°, Ranging Distance : 2cm – 500 cm/1" - 16ft, Resolution : 0.3 cm
MQ-2/ MQ-4 GAS SENSOR	Power supply needs: 5V, Interface type: Analog, Pin Definition: 1- Output 2-GND 3-VCC, High sensitivity to CH4, Natural gas, Small sensitivity to alcohol, smoke, Fast response, Stable and long life, Simple drive circuit, Size: 40x20mm
LOAD/Weight SENSOR 50KG	A half-bridge load sensor Features Sturdy material, Up to 50kg sensor range, Dimension (mm): 28*28*8, Capacity (kg): 50, Comprehensive error (%F.S): 0.2, Output sensitivity (mv/v): 1.1±0.15, Nonlinearity (%F.S): 0.2

5.2.1. Software Requirements

Table 5.2 describes the hardware requirements of the Smart Bin system.

Table 5.2: Software Requirements

Software	Description
Operating System	Microsoft Windows XP or higher
Android App	Virtuino; an Android app for monitoring sensors or control electrical devices via Bluetooth, local Wi-Fi or Internet
Internet Browser	Any internet browser. Google Chrome is Preferred
Arduino IDE	Arduino IDE Version 1.6.* or higher
ThingSpeak API	An IoT platform uses channels, REST web API to collect and store sensor data in the cloud sent from apps or devices.

5.3. Server Configurations

In this study, I use ThingSpeak as my cloud server. ThingSpeak is an Internet of Things (IoT) platform that lets you collect and store sensor data in the cloud and develop IoT applications. ThingSpeak aids for server storage of the sensor data, and aggregation to the end user devices.

5.3.1. Creating new Channel

The channel is the API node that allows for communication from the arduino code (using an API Key) to the server, and thereafter, generates a channel ID to facilitate communication to the terminal end user device. Below figure 5.1 and 5.2 illustrate the setup

My Channels

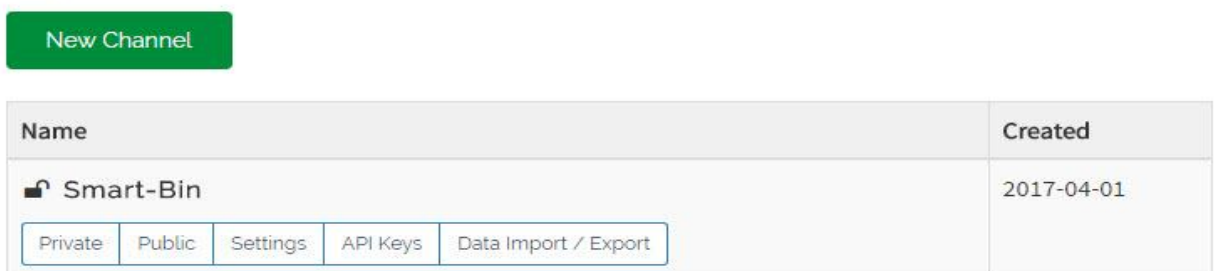

Figure 5.1: Channels Menu

Click on 'New Channel' the system will generate automatically a Channel ID, and require you to populate the sensors available for your project as below figure 5.2

Private View Public View Channel Settings API Keys Data Import / Export

Channel Settings

Percentage complete 65%

Channel ID 251601

Name Smart-Bin

Description A Smart-Bin Prototype for In-House Waste Management Project

Field 1 Gas Level

Field 2 Fill-Level

Field 3 Weight

Field 4

Help

Channels store all the data that a ThingSpeak application collects. Each channel includes eight fields that can hold any type of data, plus three fields for location data and one for status data. Once you collect data in a channel, you can use ThingSpeak apps to analyze and visualize it.

Channel Settings

- Channel Name:** Enter a unique name for the ThingSpeak channel.
- Description:** Enter a description of the ThingSpeak channel.
- Field#:** Check the box to enable the field, and enter a field name. Each ThingSpeak channel can have up to 8 fields.
- Metadata:** Enter information about channel data, including JSON, XML, or CSV data.
- Tags:** Enter keywords that identify the channel. Separate tags with commas.
- Latitude:** Specify the position of the sensor or thing that collects data in decimal degrees. For example, the latitude of the city of London is 51.5072.
- Longitude:** Specify the position of the sensor or thing that collects data in decimal degrees. For example, the longitude of the city of London is -0.1275.

Figure 5.2: Channel Settings

5.3.2. Dash boarding

The ThingSpeak web API service was used for dash boarding and server side smart bin data management. ThingSpeak uses REST API, converting the push sensor values from the arduino microcontroller program and converts the data into tabular and graphical charts for easy tracking. Figure 5.3 below shows a sample dashboard.

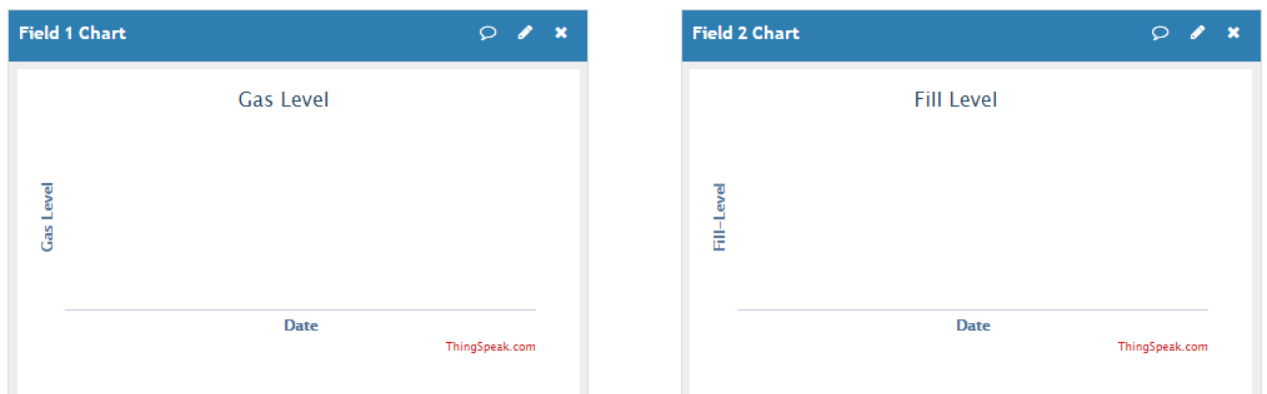

Figure 5.3: System Dashboards

5.4. Sample Application Configuration Forms

5.4.1. Adding the Sensors Channel

From The Virtuino application, the user can traverse and self-manage the configurations he/she would want to see. Important to note is that for the application to communicate to the ThingSpeak server, we required to configure the channel ID to the IOT configurations as shown in figure 5.4 below

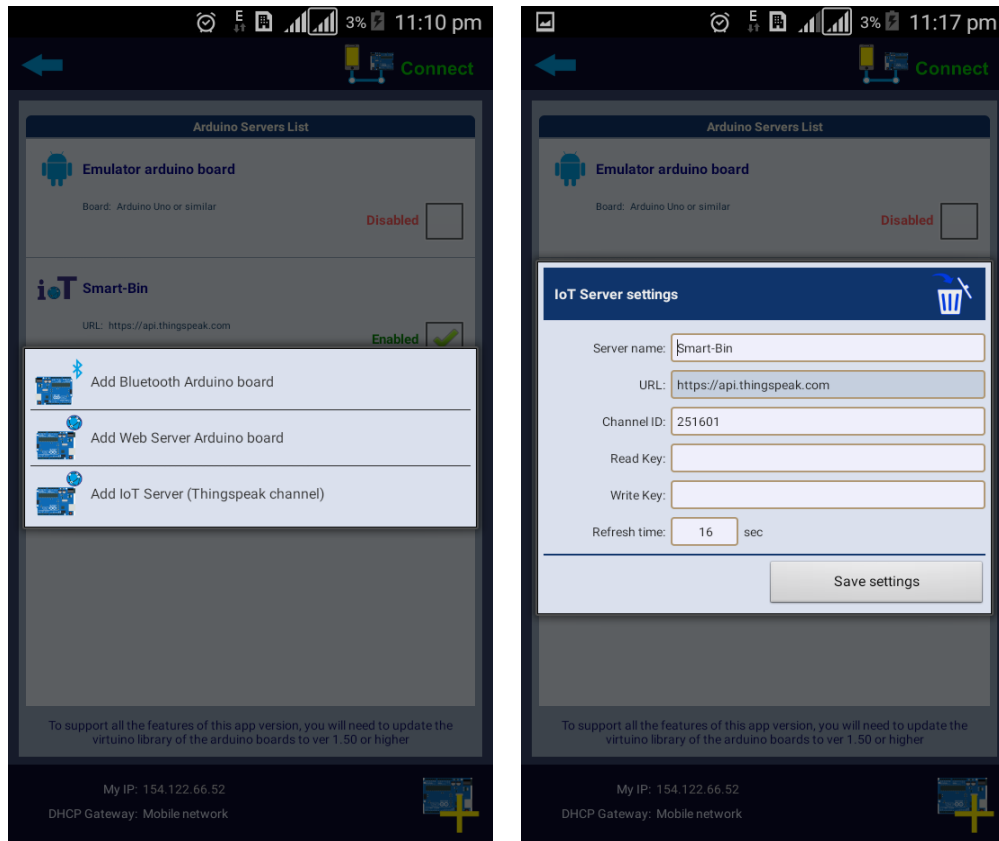

Figure 5.4: Mobile Application Configuration

5.4.2. Adding Components

The Virtuino end user application was used for remote user viewing of bin status. The user can append whatever components deems fit for viewing bin status details as shown on figure 5.5

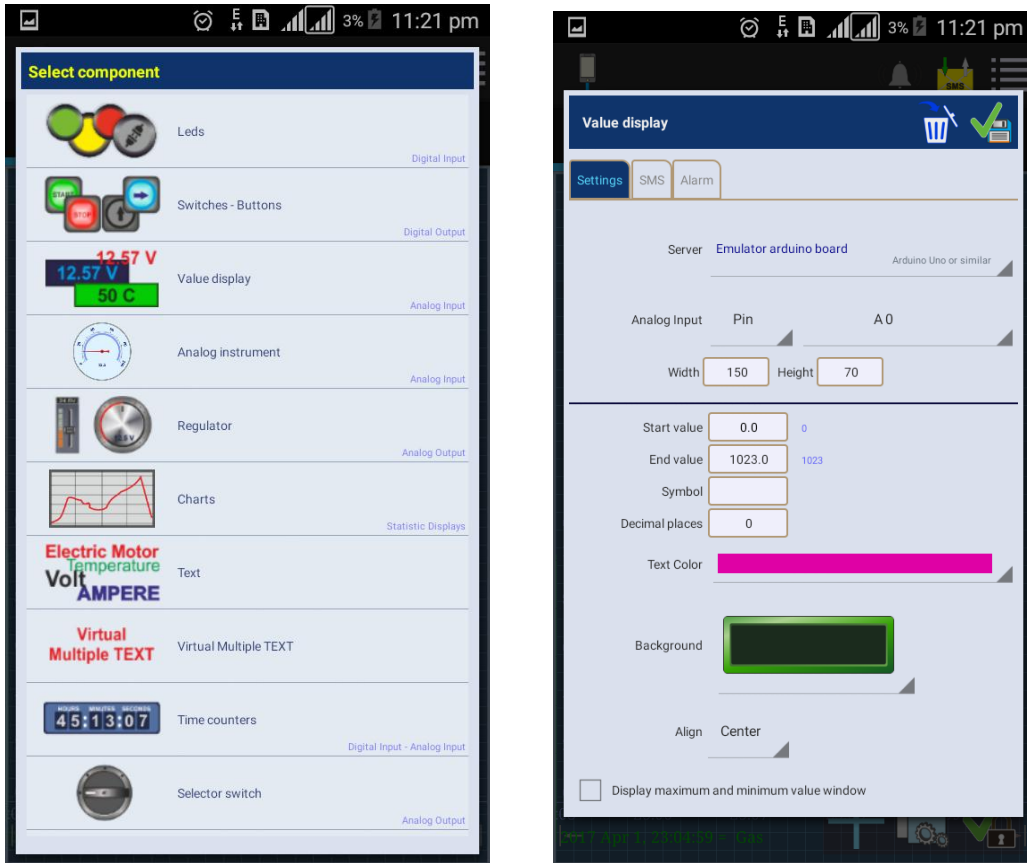

Figure 5.5: Adding Components

5.4.3. The Application Dashboard

From The Components added, example a component for each sensor device; would produce a dashboard which the user would at a glance see the bin status as figure 5.6 below

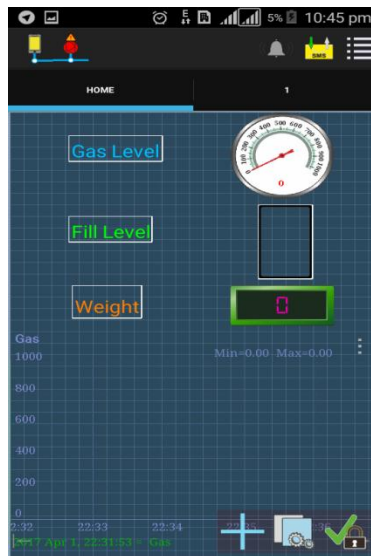

Figure 5.6: Application Dashboard

5.5. The Pseudo code

The major functionality of this prototype is the capturing of sensor information from the, Gas and ultrasonic sensors, digesting the sensor values to make sensible information and relaying this information to the Web API via HTTPS protocol.

5.5.1. Configuration Setup

The very first task of the microcontroller is to set up connection to the sensors by configuring access modes, initializing the communication pins of the Arduino (i.e. RX and TX), enabling software serial pins and initializing the serial communication.

Since the communication mode is Wi-Fi, We then must initialize the access mode of the ESP8266 module as a client, connecting via the home wireless network (Requiring access credentials configuration), to PUSH the values; REST format via web service to the ThingSpeak cloud web API. See sample pseudo code from the figure 5.7

```
void setup() {
  DEBUG=true;           // enable debug serial
  Serial.begin(9600);
  pinMode(trigPin, OUTPUT); // Sets the trigPin as an Output
  pinMode(echoPin, INPUT); // Sets the echoPin as an Input
  Serial.begin(9600); // Starts the serial communication
  espSerial.begin(115200); // enable software serial // Your esp8266 module's speed is probably at 115200
  // For this reason the first time set the speed to 115200 or to your esp8266 configured speed /
  // and upload. Then change to 9600 and upload again
  //espSerial.println("AT+RST"); // Enable this line to reset the module;
  //espSerial.println("AT+UART_CUR=9600,8,1,0,0"); // Enable this line to set esp8266 serial speed to 9600 bps
  //showResponse(1000); // Software serial doesn't work at 115200
  espSerial.println("AT+CWMODE=1"); // set esp8266 as client
  showResponse(1000);
  espSerial.println("AT+CWJAP=\"" +ssid+"\", \""+password+"\""); // set your home router SSID and password
  showResponse(5000);
  if (DEBUG) Serial.println("Setup completed");
}
```

Figure 5.7: Setup Pseudo code

5.5.2. The main Execution

This section of code contains the void loop() function. Responsible for the procedural execution of the main program block. In this block, most of the program logic iterations are carried out here, this involves parsing the sensor data from the sensors, manipulating the data to obtain meaningful information

parsed to the web API server for propagation and storage. Below is a sample code figure 5.8 for height sensor data

```
void loop()
{ // Read sensor values
  digitalWrite(trigPin, LOW); // Clears the trigPin
  delayMicroseconds(2); // Sets the trigPin on HIGH state for 10 micro seconds
  digitalWrite(trigPin, HIGH);
  delayMicroseconds(10);
  digitalWrite(trigPin, LOW); // Reads the echoPin, returns the sound wave travel time in microseconds
  duration = pulseIn(echoPin, HIGH); // Calculating the distance
  distance= duration*0.034/2;
  fillup= (height/distance); // Prints the distance on the Serial Monitor
  Serial.print("Distance: ");
  Serial.print(distance);
  Serial.println(" cm");
  Serial.print("Percentage Fill-Up is: ");
  Serial.print(fillup);
  Serial.println(" %");
  delay(2000); // thingspeak needs 15 sec delay between updates,
}
```

Figure 5.8: Main program Pseudo Code

5.5.3. PUSH to web API server

This is the next and last phase of the execution. The manipulated meaningful data is required to be ‘pushed’ to the ThingSpeak cloud resource for storage, analysis and retrievals.

In this function, the connection to the REST web service facilitated by ThingSpeak is obtained before transmission is initialized. The block of code is expected to return either a ‘successful post’ or ‘failure’ thus the function is of type Boolean. The various strings from the manipulated sensor data is parsed and pushed via the web service with the expected format.

The block also sends the length of data to be pushed then wait for a second before attempts of pushing the data is initialized. The system then keeps checking for any sort of change from the bin, guided by the sensor values. If any change is detected, the Push iterations are initialized. In case of failure, the system will respond with the error type or code, pause the push operations and close the given push iteration to allow for re-attempt with a fresh data. Refer to the below figure 5.9

```

boolean thingSpeakWrite(float value1, float value2, float value3){
    String cmd = "AT+CIPSTART=\\"TCP\\",\\""; // TCP connection
    cmd += "184.106.153.149"; // api.thingspeak.com
    cmd += "\",80";
    espSerial.println(cmd);
    if (DEBUG) Serial.println(cmd);
    if(espSerial.find("Error")){
        if (DEBUG) Serial.println("AT+CIPSTART error");
        return false; }
    String getStr = "GET /update?api_key="; // prepare GET string
    getStr += apiKey;
    getStr += "&field1=";
    getStr += String(value1);
    getStr += "&field2=";
    getStr += String(value2);
    getStr += "&field3=";
    getStr += String(value3);
    getStr += "\r\n\r\n";
    // send data length
    cmd = "AT+CIPSEND=";
    cmd += String(getStr.length());
    espSerial.println(cmd);
    if (DEBUG) Serial.println(cmd);
    delay(100);
    if(espSerial.find(">")){
        espSerial.print(getStr);
        if (DEBUG) Serial.print(getStr);}
    else{
        espSerial.println("AT+CIPCLOSE");
        // alert user
        if (DEBUG) Serial.println("AT+CIPCLOSE");
        return false;}
    return true;
}

```

Figure 5.9: PUSH to API Pseudo Code

5.6. Prototype Testing

The prototype testing strategy employed was unit testing, Integration testing and System usability tests. System and Integration testing was conducted by the developer and the target users of the system ensuring the system meets the requirements, performs the tasks as expected and that the solution measures up to the software standards ensuring usability, accuracy, robustness and responsiveness.

This study achieved the test strategies and measured and recorded as per the table 5.1.

Table 5.1: Integration and System Tests

Test case Name: Integration and System Test				
Test Date: 5th March 2017				
Test Description:				
Pre-Conditions:				
Post-Conditions:				
Test steps				
Step	Action	Expected Response	Pass/Fail	Comments
1.	Arduino to Web Service and mobile application Integrations	Fast and reliable push and pull integrations	PASS	Successful
2.	System dash board, Server side and mobile Application visualizations	Easy to follow dashboards and excellent visualizations	PASS	Successful
3.	Reporting and exporting data in different formatting	Ability to export data from the system	PASS	Successful
4.	System response time and semi-real time reporting	Ability to respond and publish information fast	PASS	Successful
6.	System configurability	Ability of system to be configured by user according to preferences	PASS	Successful

Chapter 6: Discussions

6.1. Introduction

In this chapter, the main findings with regard to the research questions are summarized and general conclusions based on the findings of the studies presented in this thesis are described. Furthermore, the strengths and limitations of this thesis are considered and discussed.

6.2. Findings

The findings of the study were obtained from the prototype testing results and the system usability questionnaire administered. Table 6.1 presents some of the results obtained from the system usability survey. The subsections below present a detailed description of the findings

Table 6.1: System Usability survey findings

	No	Yes	Other
The User interface is friendly	9.1%	81.8%	9.1%
I can use the system with minimum training	18.2%	72.7%	9.1%
I am willing to use this system for monitoring my domestic or office bin	9.1%	72.7%	18.2%

6.2.1. User Interface

From the Survey, 77.8% of the sample population agreed that the user interface was very friendly. The other 11% disagreed that it was not friendly, and another 11% responded with other different remarks. See figure 6.1

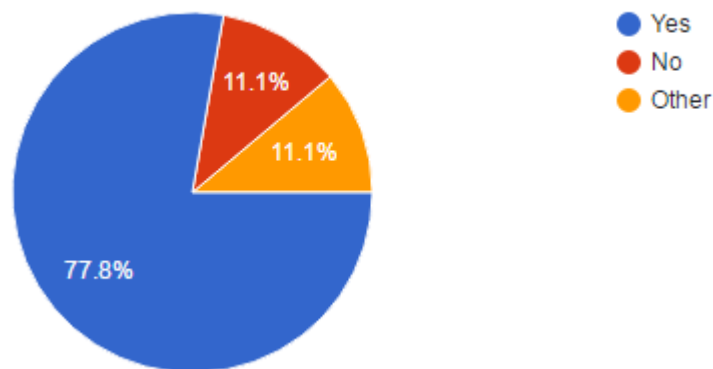

Figure 6.1: User interface is friendly

In a different survey question, 70% responded that they could use the system with minimum training, 20% disagreed with this and another 10% responded neutrally with different comments. See figure 6.2 below

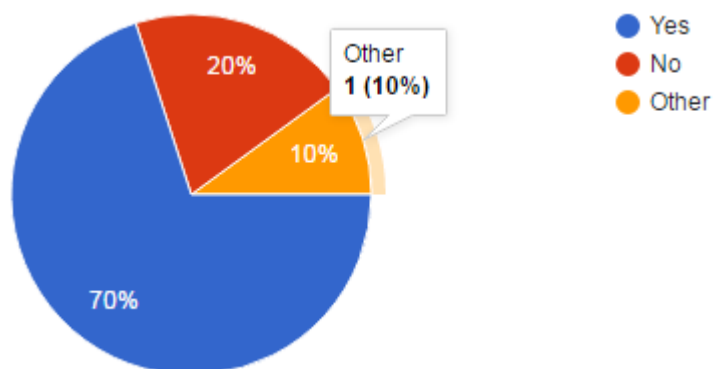

Figure 6.2: Can use system with minimal training

6.2.2. Performance

On performance, we subjected the respondents on the bin monitoring capabilities of the system. 40% of the respondents agreed that Monitoring bin on pungent smell and Fill level is easier and takes shorter duration as compared to the current method. 30% disagreed to this and another 30% responded neutrally with comments. See figure 6.3 below

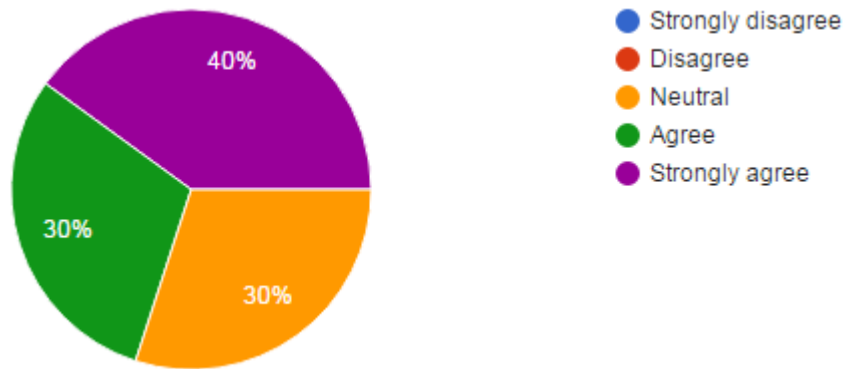

Figure 6.3: Monitoring is fast and easy

6.2.3. Convenience

The convenience was also measured. 45.5% Strongly agreeing that the system was highly convenient. An Additional 36.4% agreeing that the system was convenient. And another 18.2% were responded neutrally about this. See figure 6.4 below.

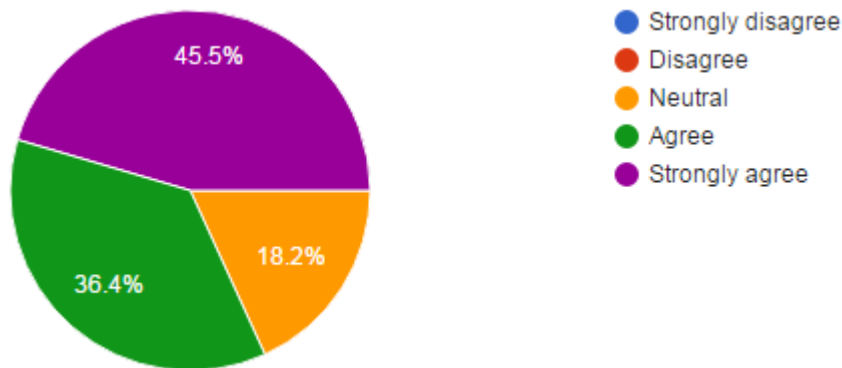

Figure 6.4: System Convenience

6.2.4. Reliability

This was measured by the willingness of the research sample to use the system and their likelihood to recommend the system to others. 72.2% were willing, 9.1% were not willing and 18.2% were unsure about this. Additionally, 45.5% responded they were very likely to recommend it to others, 36.4% likely, 9.1% neutral and another 9.1% not likely.

6.3. Limitations of the Prototype

Through the study, the researcher noted that the public would want to opt for battery supported smart bins. This research however does not address this issue. Again, a bigger percentage of the population was not completely comfortable with the system requiring Wi-Fi connectivity. The scope of this work though does not cater for this gap.

Chapter 7: Conclusion and Recommendations

7.1. Conclusions

Managing in-house bins has been an unidentified but highly potential hazard for human habituated areas. The current method of manually peeping through the bins and checking fill-level might lack comprehensiveness as it lacks to measure pungent gaseous content, and would be prone to forgetfulness.

As pinpointed from the research study through the administered questionnaires, most members of the public find it difficult to use the current methods for monitoring bin information over a period of time. The method is dependent on numerous physical checks of the bins, which makes the method tiresome and non-reliable.

This research therefore takes advantage of the IOT concept and use of algorithms to come up with a sensor-based system for detection and monitoring of bin fill-level and gas content, and transmit this information to the user via dashboards and reports. The users can also configure notifications and be notified upon certain triggers as bin fill-up.

7.2. Recommendations for Future Work

Through this study, the research results identified that the public would want to opt for battery supported smart bins. This research however does not address this issue. I would propose this as a feature for future development. Again, a bigger percentage of the population was not completely comfortable with the system requiring Wi-Fi connectivity. The scope of this work though does not cater for this and would be a keen area of interest for future work.

Appendix A: Turnitin Similarity index

Appendix B: User Requirements Questionnaire

User Requirements Questionnaire

Researcher: Eric M. Mware

MSc. IT, Strathmore University

This survey will be used for academic purposes only. Its main objective is to collect the user requirements to create an in-house Smart Bin prototype for household domestic and corporate users in Kenya. Kindly provide your honest answers to the following questions. Please note that your answers will be treated as private and confidential and will be used for this study only.

1. What is your County of residence?
2. Which Estate?
3. Trash bins for domestic household and corporate user are easy to monitor on Gas emission and Fill level?
 - Strongly Agree
 - Agree
 - Neutral
 - Disagree
 - Strongly Disagree
4. The Current method of bin monitoring is efficient?
 - Strongly Agree
 - Agree
 - Neutral
 - Disagree
 - Strongly Disagree
5. The system allows for the system user/operator to specify the fill level they consider optimal?
 - Strongly Agree
 - Agree
 - Neutral
 - Disagree

- Strongly Disagree
6. The household user or management personnel are promptly alerted when a bin fills up or emits a lot of gas?
- Strongly Agree
 - Agree
 - Neutral
 - Disagree
 - Strongly Disagree
7. The current process of bin management is user friendly?
- Strongly Agree
 - Agree
 - Neutral
 - Disagree
 - Strongly Disagree
8. The current process and system for bin monitoring provides a dashboards and reports for household user to monitor bin status patterns?
- Strongly Agree
 - Agree
 - Neutral
 - Disagree
 - Strongly Disagree
9. The current system allows user to check current bin status at any time?
- Strongly Agree
 - Agree
 - Neutral
 - Disagree
 - Strongly Disagree
10. I believe the current systems and processes, if any, for bin monitoring are secure and the data is safely kept?
- Strongly Agree

- Agree
- Neutral
- Disagree
- Strongly Disagree

11. If a proper computer system is implemented, I believe that domestic and corporate bin monitoring would be made easier?

- Strongly Agree
- Agree
- Neutral
- Disagree
- Strongly Disagree

Appendix C: System Usability Questionnaire

System Usability Questionnaire

Researcher: Eric M. Mware

MSc. IT, Strathmore University

This research will be used for academic purposes only. Its main objective is to collect the user experience when using the in-house Smart Bin prototype for household domestic and corporate users in Kenya. Kindly provide your honest answers to the following questions. Please note that your answers will be treated as private and confidential and will be used for this study only.

1. The User interface is user friendly?
 - Strongly Agree
 - Agree
 - Neutral
 - Disagree
 - Strongly Disagree
2. I can use the prototype with minimum training?
 - Strongly Agree
 - Agree
 - Neutral
 - Disagree
 - Strongly Disagree
3. Monitoring bin on Gas emission and Fill level is easier and takes shorter duration as compared to the current methods?
 - Strongly Agree
 - Agree
 - Neutral
 - Disagree
 - Strongly Disagree
4. The system provides a convenient way of monitoring bin status?
 - Strongly Agree
 - Agree

- Neutral
- Disagree
- Strongly Disagree

5. I am willing to use this system for monitoring my domestic and corporate bin?

- Strongly Agree
- Agree
- Neutral
- Disagree
- Strongly Disagree

6. How likely are you to recommend this system to other users?

- Strongly Agree
- Agree
- Neutral
- Disagree
- Strongly Disagree

7. Any other comments

.....

.....

.....

.....

.....

.....

.....

.....

.....

.....

.....

.....

.....

Bibliography

- Abrahamsson, P., Warsta, J., Siponen, M. T., & Ronkainen, J. (2003). New directions on agile methods: {A} comparative analysis. *25th Int. Conference On Software Engineering, Proc.*, 244–254. <http://doi.org/10.1109/ICSE.2003.1201204>
- Bachani, A. M., Koradia, P., Herbert, H. K., Mogere, S., Akungah, D., Nyamari, J., ... Stevens, K. a. (2012). Road Traffic Injuries in Kenya: The Health Burden and Risk Factors in Two Districts. *Traffic Injury Prevention*, 13(sup1), 24–30. <http://doi.org/10.1080/15389588.2011.633136>
- Bashir, A., & Bandy, S. A. (2013). Concept , Design and Implementation of Automatic Waste Management System. *International Journal on Recent and Innovation Trends in Computing and Communication*, (July), 604 – 609.
- Battese, G. E. (1995). Battese-Coelli-1995. *Empirical Economics*, 20, 325–332. <http://doi.org/10.1007/BF01205442>
- Chalkias, C., & Lasaridi, K. (2009). A GIS based model for the optimisation of municipal solid waste collection: The case study of Nikea, Athens, Greece. *WSEAS Transactions on Environment and Development*, 5(10), 640–650. Retrieved from <http://www.scopus.com/inward/record.url?eid=2-s2.0-71449113236&partnerID=40&md5=2b62a0a667c0b3241644d767d4b04cc2>
- Cobb, P., Confrey, J., DiSessa, A., Lehrer, R., & Schauble, L. (2003). Design Experiments in Educational Research. *Educational Researcher*, 32(1), 9–13. <http://doi.org/10.3102/0013189X032001009>
- Dahlén, L., & Lagerkvist, A. (2008). Methods for household waste composition studies. *Waste Management*. <http://doi.org/10.1016/j.wasman.2007.08.014>
- Dugdhe, S., Shelar, P., Jire, S., & Apte, A. (2016). Efficient Waste Collection System, 143–147.
- Folianto, F., Low, Y. S., & Yeow, W. L. (2015). Smartbin : Smart Waste Management System. In *IEEE Tenth International Conference on Intelligent Sensors, Sensor*

Networks and Information Processing (ISSNIP) (pp. 1-2).

Glouche, Y., & Couderc, P. (2013). A Smart Waste Management with Self-Describing objects. *The Second International Conference on Smart Systems, Devices and Technologies (SMART'13)*, (c), 63-70.

Hevner, A. R., March, S. T., Park, J., & Ram, S. (2004). Design Science in Information Systems Research. *MIS Quarterly*, 28(1), 75-105.
<http://doi.org/10.2307/25148625>

Islam, M. S., Arebey, M., Hannan, M. A., & Basri, H. (2012). Overview for solid waste bin monitoring and collection system. *ICIMTR 2012 - 2012 International Conference on Innovation, Management and Technology Research*, 258-262.
<http://doi.org/10.1109/ICIMTR.2012.6236399>

Karadimas, D., Papalambrou, A., Gialelis, J., & Koubias, S. (2016). An integrated node for Smart-City applications based on active RFID tags ; Use case on waste-bins.

Kasozi, A., & Von Blottnitz, H. (2010). Solid Waste Management in Nairobi: A Situation Analysis Technical Document accompanying the Integrated Solid Waste Management Plan, (February).

Khan, D., & Samadder, S. R. (2014). Municipal solid waste management using Geographical Information System aided methods: A mini review. *Waste Management & Research*, 32(11), 1049-1062.
<http://doi.org/10.1177/0734242X14554644>

KNBS. (2010). *The 2009 Kenya Population and Housing Census. Home Healthcare Nurse*.

Larman, C. (2004). *Agile and Iterative Development: A Manager's Guide. Communication*.
<http://doi.org/10.1016/j.amjmed.2009.12.017>

Lazaro, E. J. P., Alexis, E., & Rubio, J. M. (2014). Solar Powered Electronic Trash Can 1, 2(5), 33-37.

Le Vie, D. S. (2000). Understanding Data Flow Diagrams. *Proceedings of the Annual*

- Conference on Society for Technical Communication*, 396–401. Retrieved from http://ratandon.mysite.syr.edu/cis453/notes/DFD_over_Flowcharts.pdf
- Lobiondo-Wood, R., & Haber, G. (1996). Populations and sampling. *Nurse Researcher Burns St. Louis: Mosby.. Polit, D.F. and Hungler, B.P*, 3(6), 16–26.
<http://doi.org/10.1016/j.pestbp.2011.02.012>.Investigations
- Maguire, D. (1991). An overview and definition of GIS. *Geographical Information Systems: Principles and Applications*. Retrieved from [http://lidecc.cs.uns.edu.ar/~nbb/ccm/downloads/Literatura/OVERVIEW AND DEFINITION OF GIS.pdf](http://lidecc.cs.uns.edu.ar/~nbb/ccm/downloads/Literatura/OVERVIEW_AND_DEFINITION_OF_GIS.pdf)
- Malan, R., & Bredemeyer, D. (2001). Defining non-functional requirements. *White Paper 8/3/01*, 8. <http://doi.org/10.1016/j.lcats.2004.09.004>
- Mamun, A. Al, Hannan, M. A., & Hussain, A. (2013). Real Time Solid Waste Bin Monitoring System Framework Using Wireless Sensor Network, 1–2.
- Mamun, M. A. Al, Hannan, M. A., Hussain, A., & Basri, H. (2013). Wireless sensor network prototype for solid waste bin monitoring with energy efficient sensing algorithm. *Proceedings - 16th IEEE International Conference on Computational Science and Engineering, CSE 2013*, 382–387. <http://doi.org/10.1109/CSE.2013.65>
- Mamun, M. A. Al, Hannan, M. A., Islam, M. S., Hussain, A., & Basri, H. (2015). Integrated sensing and communication technologies for automated solid waste bin monitoring system. *Proceeding - 2013 IEEE Student Conference on Research and Development, SCOReD 2013*, (December), 480–484.
<http://doi.org/10.1109/SCOReD.2013.7002636>
- Monika, K. A., Rao, N., Prapulla, S. B., & Shobha, G. (2016). Smart Dustbin-An Efficient Garbage Monitoring System, 6(6), 7113–7116.
<http://doi.org/10.4010/2016.1694>
- National Environment Management Authority, K. (NEMA). (2014). *The National Solid Waste Management Strategy*.

- Olsson, S., Lymberis, A., & Whitehouse, D. (2004). European Commission activities in eHealth. *International Journal of Circumpolar Health*.
<http://doi.org/10.3402/ijch.v63i4.17747>
- Poh, M. Z., McDuff, D. J., & Picard, R. W. (2011). Advancements in noncontact, multiparameter physiological measurements using a webcam. *IEEE Transactions on Biomedical Engineering*, 58(1), 7-11.
<http://doi.org/10.1109/TBME.2010.2086456>
- Polit D.F. Bernadette PH. (1999). *Nursing Research- Principles and methodology. 6th edn. Philadelphia: Lippincott Publications.*
- Prassler, E., Stroulia, E., & Strobe, M. (1997). Office Waste Cleanup : An Application For Service Robots. *International Conference on Robotics and Automation*, (April), 1863-1868.
- Thakker, S. (2015). Smart and Wireless Waste Management, 0-3.
- Yin, R. K. (2003). Case study methodology R.K. Yin (2003, 3rd edition). Case Study Research design and methods. Sage, Thousand Oaks (CA)..pdf. In *Case Study Research: design and methods* (pp. 19-39-106).
- Zurbrügg, C. (2003). How to Cope with the Garbage Crisis, (February), 1-13.