



**Strathmore**  
UNIVERSITY

Strathmore University  
**SU+ @ Strathmore**  
University Library

---

[Electronic Theses and Dissertations](#)

---

2019

# **An Automatic soiled linen detection prototype for Hospital ward caregivers**

**James L. Akumonyo**

*Faculty of Information Technology (FIT)  
Strathmore University*

Follow this and additional works at <https://su-plus.strathmore.edu/handle/11071/6779>

Recommended Citation

Akumonyo J. L. (2019). *An Automatic soiled linen detection prototype for Hospital ward caregivers* (Thesis). Strathmore University. Retrieved from <https://su-plus.strathmore.edu/handle/11071/6779>

This Thesis - Open Access is brought to you for free and open access by DSpace @Strathmore University. It has been accepted for inclusion in Electronic Theses and Dissertations by an authorized administrator of DSpace @Strathmore University. For more information, please contact [librarian@strathmore.edu](mailto:librarian@strathmore.edu)

# **An Automatic Soiled Linen Detection Prototype for Hospital Ward Caregivers**

Lidonde, James Akumonyo

Submitted in partial fulfillment of the requirements for the Degree of Masters of Science in  
Information Technology at Strathmore University

Faculty of Information Technology

**Strathmore University**

**Nairobi, Kenya**

April, 2019

## **DECLARATION**

I declare that this work has not been previously submitted and approved for the award of a degree by this or any other University. To the best of my knowledge and belief, the thesis contains no material previously published or written by another person except where due reference is made in the research proposal itself.

© No part of this research proposal may be reproduced without the permission of the author and Strathmore University

Lidonde James Akumonyo

.....

.....

## **Approval**

The thesis of Lidonde, James Akumonyo was reviewed and approved by the following:

**Dr. Vincent O. Omwenga,**

Academic Director

Faculty of Information Technology

Strathmore University

**Dr. Joseph Orero,**

Dean, Faculty of Information Technology,

Strathmore University

**Professor Ruth Kiraka,**

Dean, School of Graduate Studies,

Strathmore University

## **Abstract**

The well-being of a hospital patient is highly prioritised by the provision of a clean and safe environment with the aim of improving the rate of patient's recovery. Continuous patients' checks and alert mechanisms are essential to the caregiver in aiding them to ensure a clean and safe environment is maintained for the patient receiving medical care from the facility. The existing system used relies on scheduled visits done by nurses during their shifts to assess the nature of the patients whilst assisting them where necessary. This process is usually cumbersome and prone to neglect which leads to patients getting new hospital-acquired infections. In other cases, the unpredictable nature of patient's condition may result to high incontinence where the patient may soil linen more frequently due to deterioration of their health condition and this would need to have the caregiver promptly notified when such an event occurs to have the patient linen changed. With this challenge experienced, the study aims to come up with a solution termed as a soiled linen detection prototype to alert hospital ward caregivers of soiled linen. During this process, the researcher employed the use of experimental research to determine the variables essential in soiled linen detection. Together with this prototyping and use of questionnaires were employed to fine tune the system into meeting the users' requirement as a solution to soiled linen detection challenge. The solution created integrates the idea of IoT with Wireless Sensor Networks. Hospital beds will be attached to humidity and gas sensors that are connected to the IoT device. The bedlinen will cover the sensors and they will transmit the hydrogen sulphide gas levels and humidity levels to the central cloud storage system whenever the safety levels have been exceeded. Upon successfully sending of the information from the IOT equipment the web application automatically picks data entry made to the cloud database storage and displays it on the client GUI awaiting to be handled by the caregiver. The client app GUI is used by the assigned caregiver and the nurse at the central ward station to notify and locate the bed that requires attention allowing proactive response to the patient who requires bedlinen change. The results of this was a prompt notification soiled linen prototype that was able to give notification as soon as the gas and humidity levels were exceeded.

**Key Words: Soiled Linen, Patient, Hospital**

## Table of Contents

Declaration and Approval .....	<b>Error! Bookmark not defined.</b>
Approval .....	i
Abstract .....	ii
List of Figures .....	viii
Abbreviations/ Acronyms .....	x
Acknowledgements .....	xi
Chapter 1: Introduction .....	1
1.1 Background .....	1
1.2 Problem Statement .....	3
1.3 Aim .....	3
1.4 Specific Objectives .....	4
1.5 Research Questions .....	4
1.6 Justification .....	4
1.7 Limitation .....	5
Chapter 2: Literature Review .....	6
2.1 Introduction .....	6
2.2 Alternative toileting options in hospitals .....	6
2.3 Factors Used to Analyse Soiled Linen .....	8

2.3.1 Soiled linen through body fluids .....	8
2.3.2 Soiled linen from out of body elements.....	10
2.3.3 Hospital Ward Linen Change policy .....	10
2.4 Approaches used to check soiled linen .....	11
2.4.1 The sniff test .....	12
2.4.2 Body fluids colour .....	12
2.5 Existing soiled linen detection system .....	13
2.5.1 Smart diaper.....	14
2.5.2 Bedwetting alarm.....	14
2.5.3 Conceptual Model.....	14
Chapter 3: Research Methodology.....	16
3.1 Introduction .....	16
3.2 Research Design.....	16
3.2.1 System Analysis and System Requirements.....	17
3.2.2 System Design .....	18
3.2.3 System Implementation .....	19
3.3 Target Population .....	19
3.4 Data Collection Methods.....	20
3.5 Data Analysis .....	20

3.6 Research Quality .....	21
3.6 Ethical Considerations.....	21
3.7 Location of the Study .....	21
Chapter 4: System Analysis and Design.....	22
4.2 Requirement Specifications.....	23
4.2.1 Functional Requirements.....	23
4.2.2 Non Functional Requirements .....	23
4.3 System Architecture .....	24
4.3.1 Architecture Design.....	24
4.4 Process workflow .....	25
4.5 Use Case Modelling .....	26
4.6 Sequence Diagrams.....	27
Chapter 5: Implementation and Testing.....	28
5.1 Introduction .....	28
5.1.1 Creating Soiled Linen Definition Rules .....	28
5.2 Assembling Components.....	29
5.2.1 Hardware Requirements .....	29
5.2.2 Software Requirements.....	30
5.2.3 Server Configuration .....	31

5.2.4 Web Page.....	32
5.3 Pseudo Code.....	32
5.3.1 Software Configuration and Development Setup.....	32
5.3.2 The Main Execution .....	34
5.3.3 Push to Web API server .....	35
5.4 Prototype Testing .....	36
Chapter 6: Discussions.....	37
6.1 Introduction.....	37
6.2 Findings.....	37
6.2.1 User Interface .....	37
6.2.2 Training .....	38
6.2.3 Acceptance.....	39
6.2.4 Performance.....	39
6.3 Limitations of the Prototype.....	40
Chapter 7 Conclusion and Recommendation.....	41
7.1 Conclusion.....	41
7.2 Recommendation.....	41
References.....	42
Appendices.....	46

Appendix A: Turnitin Similarity index.....	46
Appendix B: User Requirements Questionnaire .....	47
Appendix C: System Usability Questionnaire .....	50
Appendix D: Serial Monitor readings from the DHT11 sensor .....	52
Appendix E: Serial Monitor readings from MQ2 and DHT11 sensor .....	53
Appendix F: The Integrated Prototype.....	54

## List of Figures

Figure 2.1 Optimum Zone for Humidity.....	10
Figure 2.2 Conceptual Model Diagram .....	15
Figure 3. 1 Rapid Application Development .....	17
Figure 4. 1 System Architecture .....	22
Figure 4. 2 Process Workflow .....	25
Figure 4. 3 Use Case Diagram .....	26
Figure 4. 5 Sequence Diagrams .....	27
Figure 5. 1 Soiled Linen Alert System Webpage .....	32
Figure 5. 2 Setup Pseudo Code.....	34
Figure 5. 3 Main Program Pseudocode.....	35
Figure 6.1 User Interface is Friendly .....	38
Figure 6. 2 Minimum training required on system Use .....	38
Figure 6. 3 Willingness in System Use.....	39
Figure 6. 4 Easy and Fast Detection and alert .....	40

## **List of Tables**

Table 5. 1 : Attribute Definition .....	28
Table 5. 2: Hardware Requirements .....	29
Table 5. 3: Software Components.....	31
Table 5. 4: Integration and System Test .....	36
Table 6. 1: System Usability Survey Findings.....	37

## **Abbreviations/ Acronyms**

DHT	Dynamic Humidity and Temperature
IoT	Internet of Things
MQTT	Message Queue Telemetry Transport
PPM	Parts Per Million
RH	Relative Humidity
USB	Universal Standard Bus
VOC	Volatile Organic Compounds

## **Acknowledgements**

I would start by acknowledging the almighty God the creator of heaven and earth for His grace love and immense favour during the entire process of preparing this research. Secondly, I would like to acknowledge the efforts and motivation of my Supervisor, Dr. Vincent Omwenga for his continuous motivation and guidance to see me through the completion of my work.

I pass my sincerest appreciation to my Parents Mr. and Mrs. Allan Akumonyo for believing, supporting me throughout my education journey and instilling in me the basic life skills that have pushed me to this level that I am in today.

## **Chapter 1: Introduction**

### **1.1 Background**

Soiled linen is defined as any textile item that has been contaminated by secretions and excretions from the human body. The contaminants contain a high load of microorganism and these include body fluids, blood, fecal matter, urine and sweat (Aucamp, 2016). Patients in a healthcare facility utilize the linen items and continuous use of these items leads to contamination and with time linen change is required in order to ensure patient's safety which is usually done after scheduled times or whenever the caregiver has been alerted of soiled linen (Asfour & El-Soussi 2016). The use and change of these linen items are varied depending on the hospital ward policy and soiled condition of the linen item with a varied frequency dependent on individual cases (Garfoot & Knock, 2017).

High concern for linen change is usually given to patients in the critical care units in comparison to the other wards (Kumar, Sujith, Vignesh, & Shivakumar, 2016). However, it should be noted that the condition of the patient in any ward can easily deteriorate resulting in the need of utilising more linen than initially intended. A research done by James and Skinner (2011) discovered that the change in patients' acuity results to an average increase of linen use by 11%. Normally patients in a hospital do have relieving equipment close by to enable them adequately use them whenever necessary. The equipment used in this scenario varies depending on the patient's condition and mobility in the hospital. Most general wards employ the use of such as bedpans, portable commodes and portable urinals require the patient to be given assistance in order too comfortably use them (Woolston, 2019). This assistance involves a change in body positioning so as to properly fix the equipment for use and thereafter properly remove the equipment to avoid spillage onto the bed. Lack of a caregiver close by results to the patient relieving themselves due to the discomfort that they are experiencing. The underlying cause for these situations is tied upon the fact that the patient has reduced control of the bowel movement also called incontinence and as a result they are prone to easily soil the linen and upon detection caregivers need to be alerted in order to change the patient's linen (Binks, De Luca, Dierkes, Herrero, & Niederalt, 2015).

Present detection methods utilised in checking of soiled linen are dependent on the scheduled time visits done by the nurses during what they term as turn procedure (Jocelyn, Thiara, Lopez, & Shorey, 2017). This is a procedure undertaken after every two hours and helps in assisting the patients' well-being especially those who are bedridden. This procedure helps the caregivers to identify issues such as the need for linen change whilst at the same time helping avoid the emergence of hospital-acquired infections. Hospital-acquired infections or nosocomial infections have been termed as infections that patients get while receiving treatment for medical and surgical conditions (CDC, 2017). These conditions occur in all settings of care which includes hospitals, surgical centres, ambulatory clinics and long term care facilities such as nursing homes and rehabilitation facilities. The cases of nosocomial infections in hospitals result in a high rate of mortality and morbidity. In Europe Health care-associated infections alone attributes to 50,000 deaths per year (WHO, 2009). Kenyan statistics showcase that there are 4.4 patients per every 100 patient admissions who had nosocomial infection (Ndegwa, 2015).

The above detection mechanisms being manual and dependant on the nurse physically checking the patient results to the need of employing modern technology that can empower the nurse to easily identify and specifically address the need of patient linen change before patient's safety is compromised. With this, it is coherent that a soiled linen detection prototype that automatically detects soiled linen and has a timely intervention mechanism such as alerting the required nurse or caregiver, is cost effective and can transmit data to a server is developed. The evolution of the Internet of things has brought along low-cost hardware such as the sensors, microcontrollers and network communication modules that can work be customised and programmed to detect different facets such as temperature, hydrogen sulphide gas humidity amongst others and send the information via the internet to a server. This research aims at harnessing these capabilities and using them to tackle challenges facing soiled linen detection.

## **1.2 Problem Statement**

The human body excretes and secretes body fluids from its system as part of its natural process. These body fluids get to contact with the linen items, they become contaminated with pathogens and long exposure to the pathogens will result to patients' discomfort and exposure to other infections (Ministry Of Public Health And Sanitation, Ministry of Medical Services, 2010). The task of ensuring patients safety is undertaken by the nurses or caregivers. Among the areas they manage include changing of soiled patient linen upon detection of linen being soiled. This process is usually undertaken in compliance with the hospital ward linen change policy, which varies in respect to the condition of the patient and the ward type (Kumar et al., 2016). Even though nurses endeavour to follow these policies and procedures, they are mostly understaffed and overstretched. This in effect translates to reduced quality of patient's wellbeing and as such patient can easily overstay with linen without their knowledge. Case example, WHO (2018) recommends the ratio of 2.3 nurses and midwives per every 1,000 people. The Kenyan figures available are for the year 2014 indicate the ratio as 1.5 nurses per 1000 people being an increase from the 0.368 nurses and midwives ratio that we had in the year 2008 (WHO, 2018).

Nurses and caregivers undertake several measures which revolve around ensuring the patient's environment is clean together with administering drugs and supporting the patient whenever they need help. With this acknowledged, part of the nurses or caregivers mandate is to have all soiled linen contaminated by body fluids exchanged with clean and safe linen items (Asfour & El-Soussi, 2016). The mechanisms utilised for this activity include the use of smell test, touch, observation and for the more sophisticated utilise the humidity measure to detect the need for patients to have their linen changed. This alert process is manual and ineffective as the patient is prone to overstay with soiled linen without the knowledge of the caregivers.

## **1.3 Aim**

The aim of the study is to develop an automatic Soiled Linen Detection Prototype for Hospital Ward Caregivers or nurses that proactively detects hydrogen Sulphide gas and humidity safety levels and notifies the responsible personnel on need to change the patient's linen. The notification

created will give the nurses necessary information that quickly identifies the bed where linen has been soiled

#### **1.4 Specific Objectives**

- (i) To evaluate factors used to analyse soiled linen
- (ii) To review existing techniques used to alert nurses and review their challenges
- (iii) To develop an automatic soiled linen alert system
- (iv) To carry out testing of the developed system

#### **1.5 Research Questions**

- (i) Which factors are used to analyse soiled linen?
- (ii) Which solutions are being used to alert nurses and what limitations do the solutions have?
- (iii) How can an automatic soiled linen alert system be developed?
- (iv) How will the prototype be tested?

#### **1.6 Justification**

This study helps to identify the gaps in patient's soiled linen detection system. The study will delve into developing of a detection system to benefit the patient by sending an alert to the caregiver notifying them of the bed that requires their attention in respect to change of the soiled linen with clean fresh ones. To the caregiver, they will be strategically armed with the information of linen conditions before their normal scheduled patient turning time thus helping them prioritise the checking of the patients by attending to those who have soiled their linen first then to the rest.

The results of the study might go a long way in improving the safety of the patient from long exposure to pathogens because of overstay with soiled linen leading to a clean and safer

environment to the patient's and other individuals close to the patients (Ministry Of Public Health And Sanitation, Ministry of Medical Services, 2010).

The research contribution to the existing body of knowledge would be important as it will complement and provide avenues for further research into the adoption of the use of the soiled linen alert systems.

### **1.7 Limitation**

The study will focus on creating a soiled linen detection system for the hospital healthcare facilities with a bias to inpatients. The solution may enhance proactivity in patient care by providing the nurses with adequate information to strategically respond to the need of linen change on the bed of the patient that requires their attention resulting to safer and cleaner environments for both patients and other individuals within the hospital.

The target of this study is the admitted patient and the hospital nursing team. The system developed will be able to notify the nurses of the patient's linen situation based on moisture content.

# Chapter 2: Literature Review

## 2.1 Introduction

This section provides a review of relevant literature on soiled linen with the aim of identifying parameters used to check soiled linen in hospitals. To add on this the research delves into the approaches taken to alert nurses of soiled linen, challenges faced in alerting nurses of soiled linen and thereafter identifies gaps in the existing literature as identified by the different authors with an aim of finally addressing a specific gap that the research hopes to fill by development of the system.

## 2.2 Alternative toileting options in hospitals

Hospitals have devised methods of assisting the patients to have an easy time relieving themselves whilst in the medical facilities. These mechanisms assist the patients with limited mobility especially as the distance from the bed to the bathroom may be tough for the patient (Woolston, 2019). The options include:

- i. Bedpans
- ii. Portable urinals
- iii. Portable commodes
- iv. Catheters
- v. Adult diapers(Incontinence pads)

### 2.2.1 Bedpans

This is an essential tool being used in hospital wards. The patient is assisted to use the bedpan by the caregiver where it is placed below them and they will excrete to the bedpan. There is a specific mechanism used to prepare the patient and the bed during this procedure. Upon completion of the excretion process, the caregiver carefully removes the bedpan to avoid spillage of the contents of

the bedpan to the bed. The patient is cleaned and left to relax. The use of this method relies heavily on communication from the patient when they need to relieve themselves. Patients who are able to alert the nurses and the nurses respond on time are favoured by this method. However, basing on the challenge of overstretched nurses this mechanism might not always result in quick response leaving the patient to soil the bed linen.

#### 2.2.2 Portable Urinals

Portable urinals are favoured to bedpans whenever a patient is confined to bed but able to sit or stand up. This on its own can enable the patient to relieve themselves without necessarily relying on the assistance of the caregiver during the relieving process.

#### 2.2.3 Portable commodes

These are also known as portable chairs suitable for people recovering from injuries or surgery. This is basically a lightweight metallic or plastic chair with a removable toilet bowl. The main disadvantage is that it requires the patient to be mobile.

#### 2.2.4 Catheters

They are used whenever a patient is unable to stand to use a bedside commode, the patient cannot be able to move to utilise the bedpan thus the result will be the use of the catheters. This is a tube that is inserted to drain urine from the urethra. A lot of care is needed to ensure there is no infection as a result of the use of the catheter

#### 2.2.5 Adult Diapers

This is also called incontinence Pads used for patients in the later stages of dementia. This is due to the fact that they have incontinence and will be unable to control their bowel movement as a result soiling the linen items more frequently. The cost of purchasing adult diapers is very high keeping in mind that several of these diapers may be needed during the patients stay in the facility. More so they are prone to the same challenges experienced where overstay with these diapers results to increased cases of hospital-acquired infections.

## **2.3 Factors Used to Analyse Soiled Linen**

Linen is defined as any textile material that can be cleaned and disinfected through the laundry process (UK Department of Health, 2016). On the other hand, soiled linen is defined as any linen item that has been contaminated through blood or body fluids and contains microorganisms (Aucamp, 2016).

### **2.3.1 Soiled linen through body fluids**

Contamination of linen through body fluids is as a result of excretion and secretion of body fluids. Rentokil (n.d.) defines body fluids to be liquids originating from inside the bodies of living humans and they include the following:

- i. Aqueous humour and vitreous humour
- ii. Bile
- iii. Blood serum
- iv. Breast milk
- v. Cerebrospinal fluid
- vi. Cerumen (earwax)
- vii. Endolymph and perilymph
- viii. Female ejaculate
- ix. Gastric juice
- x. Mucus (including nasal drainage and phlegm)
- xi. Peritoneal fluid
- xii. Pleural fluid
- xiii. Saliva
- xiv. Sebum (skin oil)
- xv. Semen

- xvi. Sweat
- xvii. Tears
- xviii. Vaginal secretion
- xix. Vomit
- xx. Urine

The above examples are classified into two broad categories which are secreted body fluids and excreted body fluids. Secreted body fluids originate from the process of sending or eliminating unwanted materials from the body and the examples of materials to note during secretion include hormones, saliva, enzymes, mucus, tears, sweat and sebum (Clancy & McVicar, 2009).

Excreted body fluids imply to the situation where metabolic waste and nitrogenous by-products of metabolism are removed from the body system. This is a critical mandate in all living things and in the human body it is carried out by the lungs, kidneys and skin with the excreta being carbon dioxide, sweat and urine respectively (Clancy & McVicar, 2009).

The above fluids lead to loss of water from the body but the common major liquid loss is through Sweat and Urine. The human body can lose up to 2 litres of water through sweat per hour to a maximum of 16 litres of water loss through sweat per day depending on temperature and sedentary conditions (Grandjean, 2004). In the case of water loss in adults through urine, the range per day is given from 1 to 2 litres per day to about 20 litres per day with the large liquid intake (EFSA , 2010). In events of continence through bowel movement, the normal condition results in quite small water loss amounts of about 100 to 200mL/day. However, sick patients can easily lose water through faecal matter by 5 to 8 times in the cases of diarrhoea (EFSA , 2010). The fluids secreted or excreted due to the water element present will result to change in humidity levels in the atmosphere or environment surrounding the patient more specifically closest to the region of exposure. In order to guarantee patients safety, it is essential to understand the normal range of humidity that minimizes the growth of microorganisms. The normal humidity levels and in this case relative humidity is considered safe between 30 – 50% RH. Figure 2.1 showcases the optimum

level for relative humidity for any normal human being and more so suitable to the patient in the hospital (Carel, 2013).

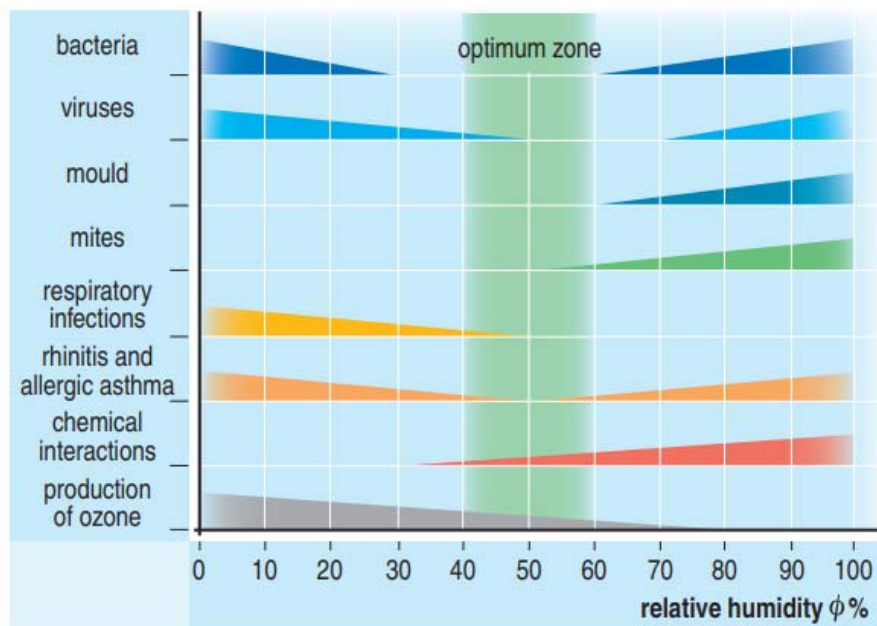

*Sterling chart taken from "Criteria for human exposure to humidity in occupied buildings"*

**Figure 2. 1 Optimum Zone for Humidity**

### 2.3.2 Soiled linen from out of body elements

Soiled linen can also get soiled from food, bed baths, dirt, skin particles and other debris and liquids that might be spilt on the linen.

### 2.3.3 Hospital Ward Linen Change policy

Every hospital ascribes to their own hospital ward linen change policy crafted to match their own needs in providing quality healthcare to their patients. The policy in effect affects the frequency of linen change by the nurses allocated to the given wards. A considerate illustration of this is used when comparing the critical care units with the normal hospital wards whereby due to the nature of patients admitted to the critical care have more of linen change is noted on an average of 9.816kg/bed/patient in comparison to 4.487kg/bed/patient for the other wards (Kumar et al., 2016).

The main reason for such a big difference occurs due to the greater risk of exposure to skin colonization and infection in the critical care units because of the presence of multidrug-resistant organism (Asfour & El-Soussi, 2016).

#### **2.4 Approaches used to check soiled linen**

Part of the clinical procedure undertaken by nurses to ensure safe and wellbeing includes turning the patient after every 2 hours (Jocelyn et al, 2017). Turning is used to assist blood circulation and it helps caregivers to analyse and prevent hospital-acquired conditions such as Hospital-acquired pressure ulcer, Pneumonia and key to our study is recurrent urinary tract infection and “diaper rash” caused by overstaying with soiled linen. Asfour and El-Soussi (2016) complement this by noting that the high risk of skin colonization and infection is attributed to the soiled linen containing multi-drug resistant organisms that are detrimental to the patient’s safety.

Caregivers usually persons who are paid or not paid can be allowed to stay with the patient during their stay in the hospital. They are the key persons who will notice and alert the required whenever they feel uncomfortable with the patient’s situation. There are several general approaches and designs used to identify the presence of soiled linen (Bikson, Cardoso, & Cancel, 2008). These include:

- i. Gas Detector/The sniff/smell test
- ii. Linen colour change
- iii. Humidity or capacitor sensors
- iv. Thermal sensors
- v. Ultra Violet light
- vi. pH-Change wetness indicator
- vii. Chromatography

### **2.4.1 The sniff test**

The common olfactory sense of dirty linen soiled through faecal and urine has been characterised through the smell of several gases (Huadong & Siegel, 2000). These include: hydrogen sulphide which has a rotten egg smell, ammonia occasional described to have a strong pungent smell whilst methane and hydrogen are odourless to humans. The normal hydrogen Sulphide content in the air is usually between 0.00011ppm - 0.00033ppm and on increased level detectable with the nose due to its pungent nature (VRPA Technologies, 2010).

Body odour, on the other hand, is attributed to the breakdown of odourless sweat by bacteria present on the skin called Corynebacterium and some Staphylococcus species to produce six main volatile organic compounds (VOC) that cause the odour (Dean, 2016). These VOC include:

- i. Butyric acid (strong, rancid butter-like odour)
- ii. Dimethyl disulphide (unpleasant, onion-like odour)
- iii. Dimethyl trisulphide (powerful odour)
- iv. 2-heptanone (banana-like fruity odour)
- v. 2-nonanone (fruity, floral, fatty, herbaceous odour)
- vi. 2-octanone (apple-like odour)

### **2.4.2 Body fluids colour**

The chemistry of bodily fluid colours is influenced by the compounds. The four main compounds include Blood, Bile Urine and faeces that are distinguished as follows

#### **2.4.2.1 Blood**

Blood consists of a protein called haemoglobin built to smaller units called haems that contain iron. When blood is oxygenated it is red in colour but when it dries up it gradually turns brown as the haemoglobin is oxidised to methaemoglobin (Brunning, 2017).

#### 2.4.2.2 Bile

This is a product of red cell degradation and is broken down to a green pigment called biliverdin which is thereafter converted to the brown pigment called bilirubin (Bunning, 2017). The brown pigmentation is usually gives faecal matter its colour. Bile is usually made in the liver to enable digesting of fat and has a colour range of yellow-green fluid (Shiel, 2018)

#### 2.4.2.3 Urine

Bilirubin is later broken down by the enzymes in the small intestines to produce urobilinogen which will be absorbed into the bloodstream and later oxidised to produce urobilin which the kidneys excrete in its yellow colour (Bunning, 2017). The yellow to golden colour is considered normal in any human being. However there are other ranges of colours that can occur due to the food that the person has taken, drugs ingested or the medical condition and these are pink or red, orange, blue and green (Khatri, 2018).

#### 2.4.2.4 Faeces

Faeces are characterised by a brown colouration as a result of the breakdown of urobilinogen to stercobilin in the digestive system (Bunning, 2017). This is not the only coloration that is present in faecal matter. Picco (2019) observes that apart from the brown coloration there are green, yellow, bright red and black. Each of the coloration does not necessarily imply that the condition is serious but is partially due to what the person eats.

### **2.5 Existing soiled linen detection system**

One of the key aspects in ensuring a clean and safe environment to the patient is promptly alerting the caregiver of the existence of soiled linen. The role of alerting the caregiver will allow for quick response to the need for linen change for the patient.

### **2.5.1 Smart diaper**

This innovation has been created with various variations some of which measure humidity levels within the diaper others faecal matter or both humidity and faecal content. A key example is the Monit's smart diaper sensor that helps parents avoid the sniff test (Shu, 2016). The Monit diaper has a Bluetooth transmitter that buzzes your phone whenever the baby required a change. Due to the nature of the absorbent elements in the baby diapers, this prototype is yet to hit the market. The stigma contained with diapers in hospitals leads to them not being a preferred means of containing excreta in hospitals. More so the cost of adult diapers is quite expensive for most of the hospitals and patients to afford.

### **2.5.2 Bedwetting alarm**

Bedwetting alarm has been used as one of the safest solutions to the challenges in children especially those who still wet their beds beyond age 7. This device helps them wake up whenever it senses liquid being released from their urethra (WebMD , 2018). Continuous use of these results to the child automatically waking by their own whenever they feel the urge to relieve themselves and is usually after an approximate period of 4 to 6 weeks.

### **2.5.3 Conceptual Model**

The system prototype consists of an Arduino Microcontroller used to interface the sensor system to the centralised system. Beds in a ward are embedded with gas and humidity sensors that are connected to the centralised system. The sensors attached to the beds transmit the gas and humidity levels to the centralised system which checks the safety levels allowed for patients admitted to the given wards. Upon exceeding the safety limits a notification alert with the bed identification information is sent to the responsible nurse to undertake the required action. A similar message is also sent to the web-based application on the central nurse station that acts as a secondary notification of the patient's bedlinen condition that requires change. Databases maintained in the central system can be used to generate reports that can go a long way in improving the handling

and care of patients. This prototype is aimed at ensuring soiled linen measuring parameters are continuously being checked to try to achieve patients' comfort during their stay in the hospital. This will assist in reducing the soiled linen alert time and in effect assist reduce the response time of changing soiled linen items. The cascading effect created will be limiting hospital-acquired infection due to overstayed soiled linen and a faster rate of recovery of the patients contributed by clean and safe linen environment. Figure 2.2 illustrates the conceptual design.

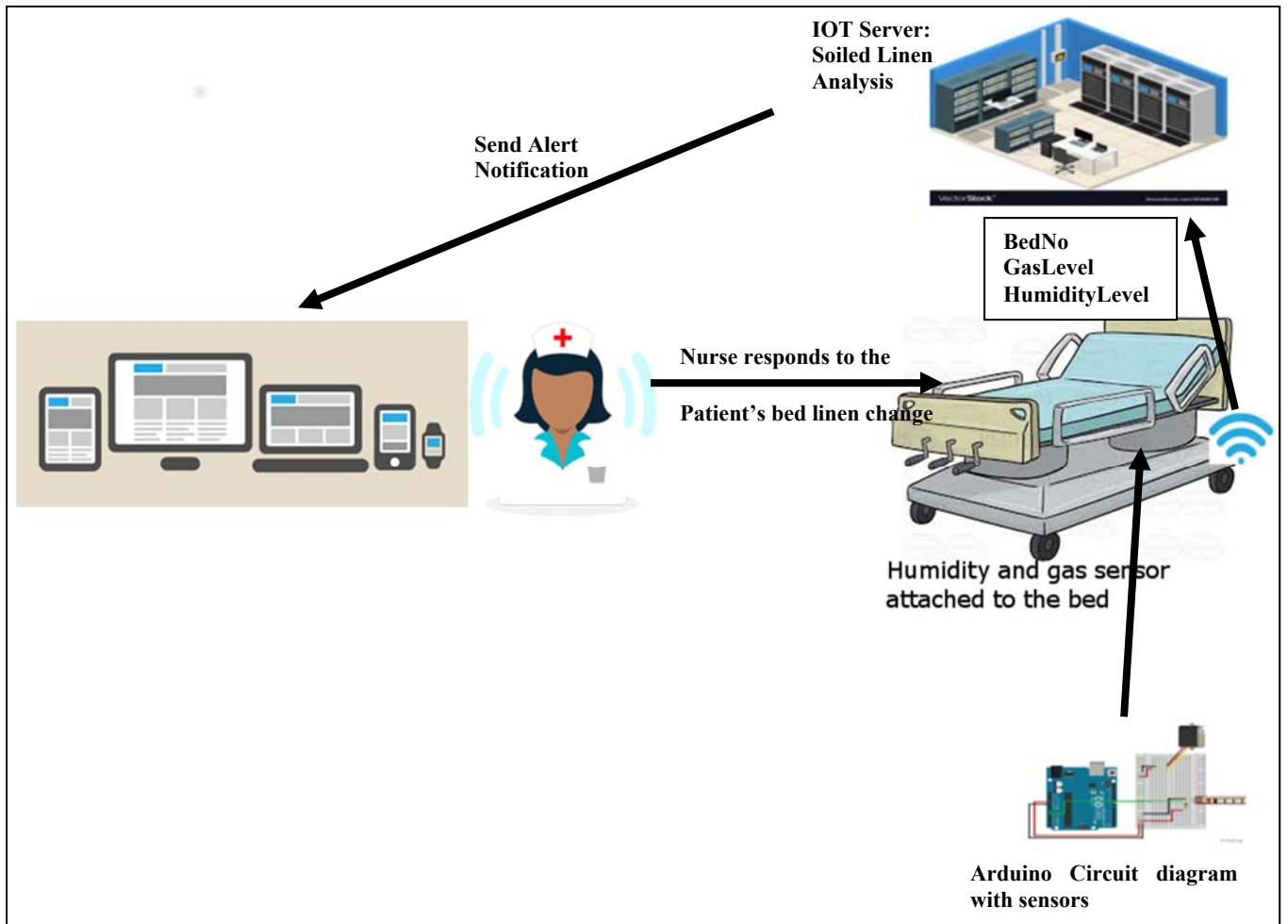

**Figure 2.2 Conceptual Model**

## **Chapter 3: Research Methodology**

### **3.1 Introduction**

This chapter describes the methodology used during the research study as well as the development of the system. The selection of a specific method is important because it details the study approach towards the attainment of the proposed research objectives. It is important to note that there are numerous options for data collection tools and research designs that a researcher can use. Therefore, adequate backing on the suitability of the chosen approaches during the research study have been used in the research.

### **3.2 Research Design**

The research proposes to develop a soiled linen alert system prototype for hospital ward caregivers that will accept sensor value data as input and use the analysis to determine linen safety levels through detecting of the humidity and hydrogen sulphide gas levels of the soiled linen. To achieve this there is a need to employ a true experimental design. A true experimental design is known by random participants' selection and assignment to the group of study in this case hospital wards.

The experiment involved the use of the MQ136 gas sensor, humidity sensor that recorded the different situation in a controlled environment that simulates all possible patient scenarios of soiling the linen. The readings were recorded and the data was used later to inform the development of the prototype. The results of the experiment will be discussed later in chapter 4 of this research.

Secondary data collection was also crucial as it is a depiction of the data that is available for use for other research. In this research, it is imperative to note there is information available of the technologies that have been used for soiled linen detection and with consideration to those that have a sensor detection mechanism attached to them. This information will be crucial to ascertain what the safety levels of soiled linen are via the usage of literature from credible sources.

### 3.2.1 System Analysis and System Requirements

The methodology in use will be Rapid application development (RAD) methodology as it will enhance prototyping whereby it will allow for quick processing with limited requirements. The use of prototyping will allow the users to test and make recommendations before final rollout (wood, 2004). Secondly RAD enables quick and easy development with an addition of increased quality of the final product without the need for an extensive upfront data collection and planning (Mall, 2018).

Rapid Application Development (RAD)

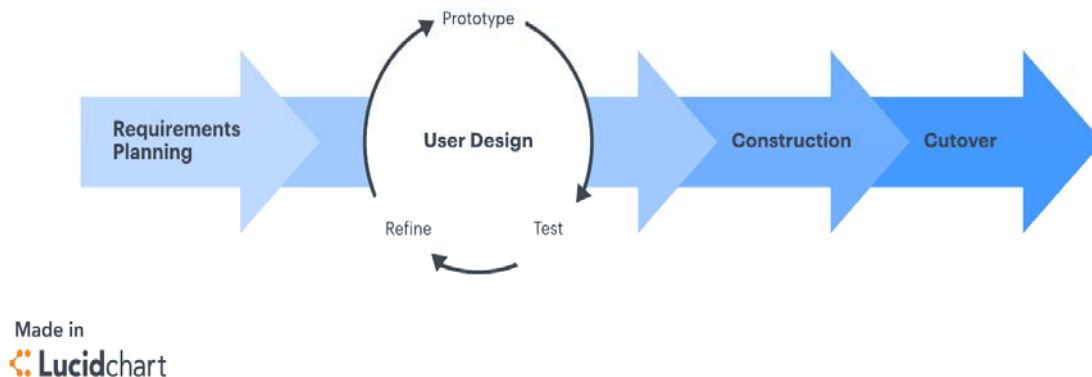

**Figure 3. 1 Rapid Application Development**

The RAD process commenced with the development of preliminary data models and the required business process models in the initial requirement planning stage. The subsequent reiterative process involved the user design, data and process models being prototyped, tested and refined. Subsequently, the development yielded in the combination of the business requirements, technical design statement and testing for the construction of the prototyped system.

Obtaining of the requirements from the required stakeholders was achieved by administering Questionnaires and building of prototypes. This combination was a wholesome approach in

requirement collection from a diverse set of the involved stakeholders within the healthcare facility.

#### 3.2.1.1 Questionnaires

The use of Questionnaires to gather the requirements was more informal and as a tool, it enhanced the collection of stakeholder's information from the various health facility areas. The questionnaire was vital as it enabled the fast collection of valuable information from stakeholders.

#### 3.2.1.2 Prototyping

This is a modern technique used for data collection where the initial requirements gathered will be used to develop an initial solution prototype. This prototype is exposed and tested by the users where they would give their suggestions on things that can be adjusted, and more data requirements will be collected at this stage. These changes will be effected and the improved prototype given back to the user again. This process will be repeated until the solution meets the required business needs.

### **3.2.2 System Design**

The soiled Linen alert system design was derived from the collection of user requirements and rigorous analysis of the existing methods used by caregivers' alert systems. The merging of the requirements and analysis enabled the creation of a structured system blueprint of the proposed prototype. The blueprint thereafter ushered the use of workflow diagram, use case diagrams, sequence diagrams, data flow diagrams and class diagrams.

The hardware components to be used include Arduino shield, MQ136 gas sensor, humidity sensor and a wireless module for communication was deployed. The development was done on a windows 10 platform utilising the Arduino IDE utilising C++ language for development.

### **3.2.3 System Implementation**

This phase enabled the logical and hardware development of the system from the specifications blueprints are converted into a working system prototype. The inputs in this phase included all designs as capture with the workflow diagram, use case diagrams, sequence diagram, data flow diagram and class diagrams.

During system development, several software development tools were utilised to create the proposed solution. These tools include: the Arduino IDE used as the development tool whilst on the background a web application based on JQuery language was utilised for communication between the sensors or terminal nodes of the system with the caregiver end user device through the application logic code running in the Arduino microcontroller module.

Upon completion of the implementation, tests were carried out to ensure the solution meets targeted business requirements gathered and works logically as expected. Tests deployed include programmer testing and beta testing as a measure to ensure proper working in an ideal environment with real data.

### **3.3 Target Population**

The primary population comprised of the caregivers within Kenyatta National hospital who take care of patients. The hospital services a total of 1800 beds in the public area and 209 beds in the private wing. These beds have been distributed to 50 wards, 22 outpatients and 24 theatres of which 16 are specialised (KNH, 2017). The total number of patients attended to per year is on an average of 70,000 inpatients and 600,000 outpatients attended to by a total of 1,718 nurses (KNH, 2017).

The study employed a convenience non-probability sampling method due to the busy nature of the caregivers. Convenience sampling is a random selection of sampling units within the segment of the most information on the characteristic of interest. The researcher has a higher hand as the sample is chosen based on the judgement of the researcher. In this study, the convenience sample

will work well by using sound judgement which ends up in saving time and money. To obtain a sample size sampling without replacement was used as illustrated with the below Slovin's formula (Ellen, 2018).

$$n = \frac{N}{(1+N(e)^2)}$$

e =10% N=1718 and we obtain n to be 18

Where:

n is the sample size

N is the population size

E is the margin of error

### **3.4 Data Collection Methods**

The study utilised both primary and secondary sources of data collection. Primary data was collected from the prototype information and as such the sensor technology being utilised in this study especially during the development phase while the secondary data was obtained from the questionnaires administered.

The use of questionnaires was necessary due to the time limitations more so they provide anonymity. This mechanism enables a standardised and objective mechanism of gathering the responses providing an objective approach to data gathering.

### **3.5 Data Analysis**

In order to analyse collected data and ensure consistency and completeness, the research utilised the use of spreadsheet technologies such as Microsoft Excel for quantitative data analysis. The questionnaires gathered were encoded and in an analysed and presented in a tabular format which was later translated into a graphical representation with the use of bar graphs and pie charts.

### **3.6 Research Quality**

A pilot questionnaire was administered and from the early stages, it was discovered that there few questions that would need to be placed in a good context to achieve the required output.

### **3.6 Ethical Considerations**

In this research project, the information was given voluntarily, and the respondent's data was handled confidentially. Data from secondary sources were properly cited for future reference.

### **3.7 Location of the Study**

The research was conducted in a Nairobi based inpatient healthcare facility. The facility chosen had several departments with specialised wards from the normal wards to the critical care wards such as ICU and HDU.

## Chapter 4: System Analysis and Design

This chapter looks into the system design and architecture for the development of the prototype based on the requirement specification obtained from the analysis of the data collected. It defines the different stakeholders of the system, system components, system data models and system process models. In addition to this, it will also present a visual representation of the proposed solution by the use of a visual modelling language (UML) so as to ensure the prototyped system is completely understood before construction commences.

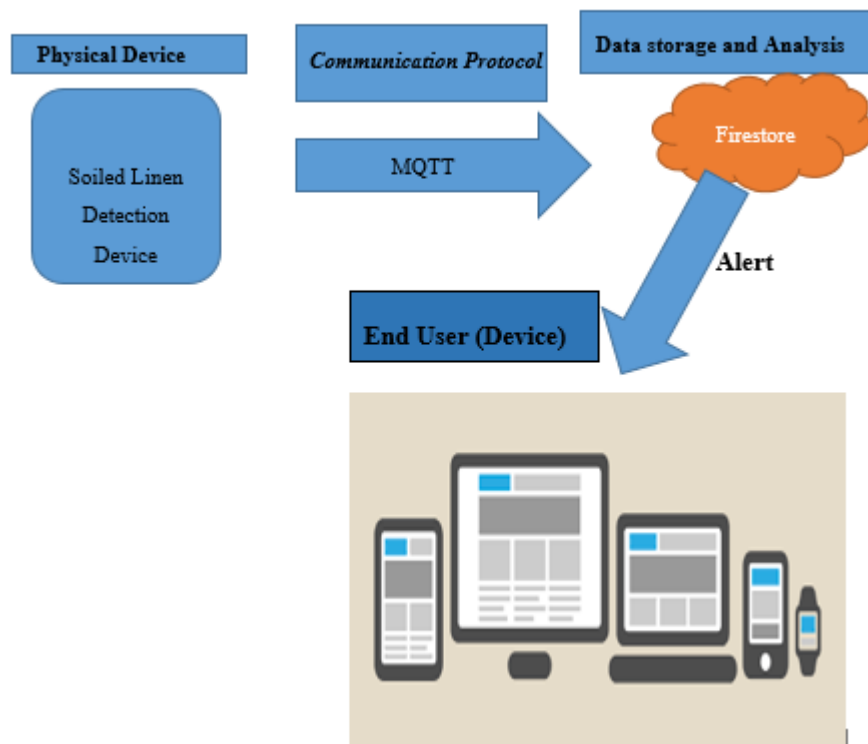

Figure 4. 1 System Architecture

## **4.2 Requirement Specifications**

Requirement specification is a complete description of the functional and non-functional requirements of the prototype that will elaborate on the behaviour of the prototype.

### **4.2.1 Functional Requirements**

Functional requirements explain what the prototype has to do by identifying the tasks, actions or activities that must be accomplished. They include:

- i. A prototype that should read gas, humidity data from the environment in the shortest time possible
- ii. A prototype that should convert the sensor data into digital form and send it to the centralised system
- iii. A prototype that should send a message alert and notification after a soiled linen instance
- iv. A prototype that should notify the required caregivers of the location and patients bed that requires linen change
- v. A prototype that can provide historical usage reporting

### **4.2.2 Non Functional Requirements**

Non-functional requirements rely on constraints and qualities. The qualities are properties or characteristics of the system that its stakeholders care about and will have a great bearing to the degree of satisfaction of the system. The non-functional requirements include

- i. Security

This aspect looks into the three critical areas of information of the CIA triad which is Confidentiality integrity and availability. This ensures the data is available to those authorised to view this information especially to the caregivers who are to respond to the patient need for a change of linen.

- ii. User Support

This section is user-focused so as to enable them to understand the system and how the prototype works. It offers notifications to enable the user to acknowledge the need for their attention to the different sectors of the ward where linen needs to be changed.

- iii. Performance

### **4.3 System Architecture**

The system architecture can be illustrated in three ways these are:

- i. Presentation layer
- ii. Application layer
- iii. Data layer

The presentation layer presents the processed data to the user devices. In our case, the use of the mobile and web application will provide the interface that will allow the user to view the information

The application layer will perform the application logic translating the information provided from the sensor technology data to valuable information for the user. This is an essential link for the presentation and the data layer for our prototype.

The data layer receives and stores data obtained from the sensor collected data that is relayed to the storage sector of our prototype

#### **4.3.1 Architecture Design**

The soiled linen detection prototype encompasses three main components which are the centralised server setup, Arduino Microcontroller used to interface the sensor system with the centralised system. Beds in the wards will be embedded with the low power and low-cost gas and humidity sensors that are connected to the centralised system. The prototypes will transmit the gas and humidity status levels to the central system. The centralised system pushes the data to the client

Graphical user interface in which the current soiled status gas and humidity level are translated according to safety levels.

#### 4.4 Process workflow

The workflow looks into the flow of data and information through the system depicting the logical design options with the associated options of actions and decisions.

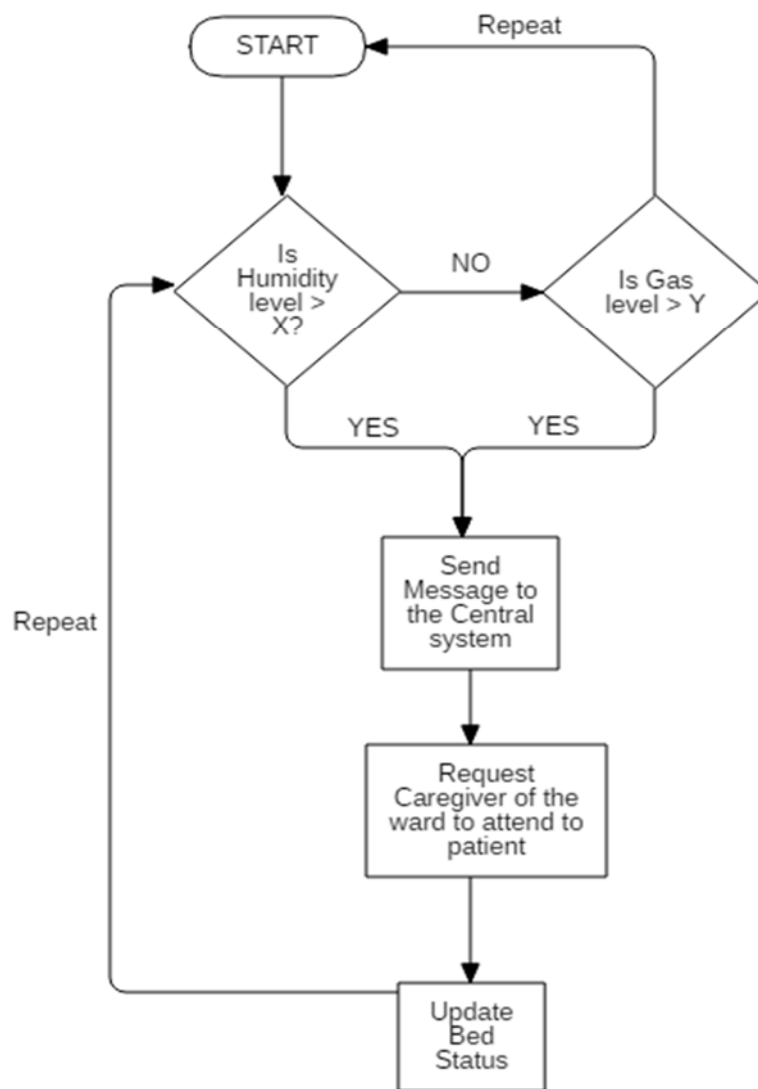

**Figure 4. 2 Process Workflow**

## 4.5 Use Case Modelling

Figure 4.2 illustrates the soiled linen detection prototype use case diagram used to offer a visual representation of the various roles of the system and how they interact with the various functions of the system. This illustration of activities showcase the functional requirements from a user's perspective.

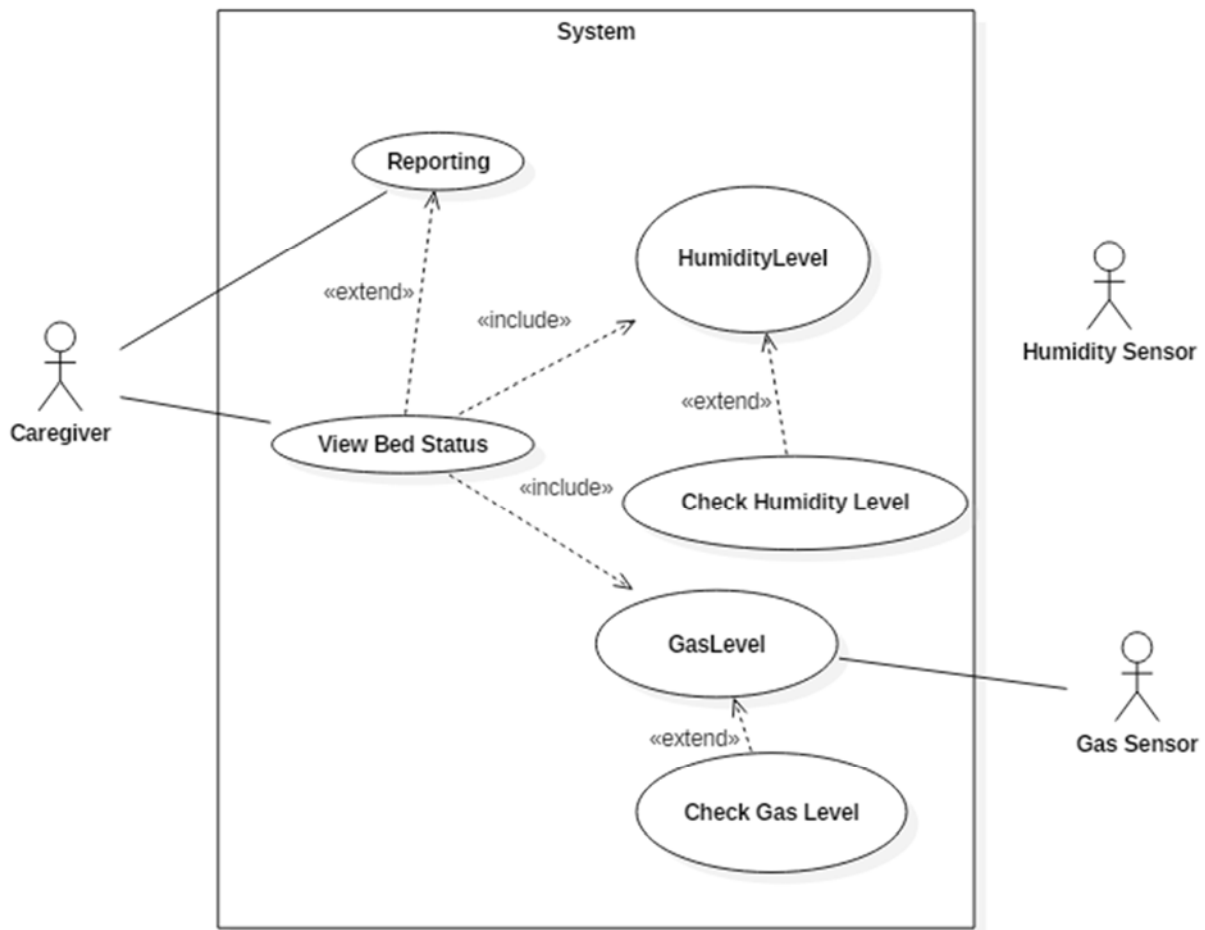

Figure 4.3 Use Case Diagram

## 4.6 Sequence Diagrams

The sequence diagram in Figure 4.3 showcases how objects interact with each other via sending and receiving of messages and response in the execution of a use case or operation. The first step involves signing up into the system. Upon successful registration into the system, the user will be able to check bed status for the different beds by utilising the web browser or a mobile browser. This action results in checking the gas level and the humidity levels, whose values are transmitted through the Arduino microcontroller to the user browser and upon exceeding of the safety limit an alert will be made to the caregiver responsible.

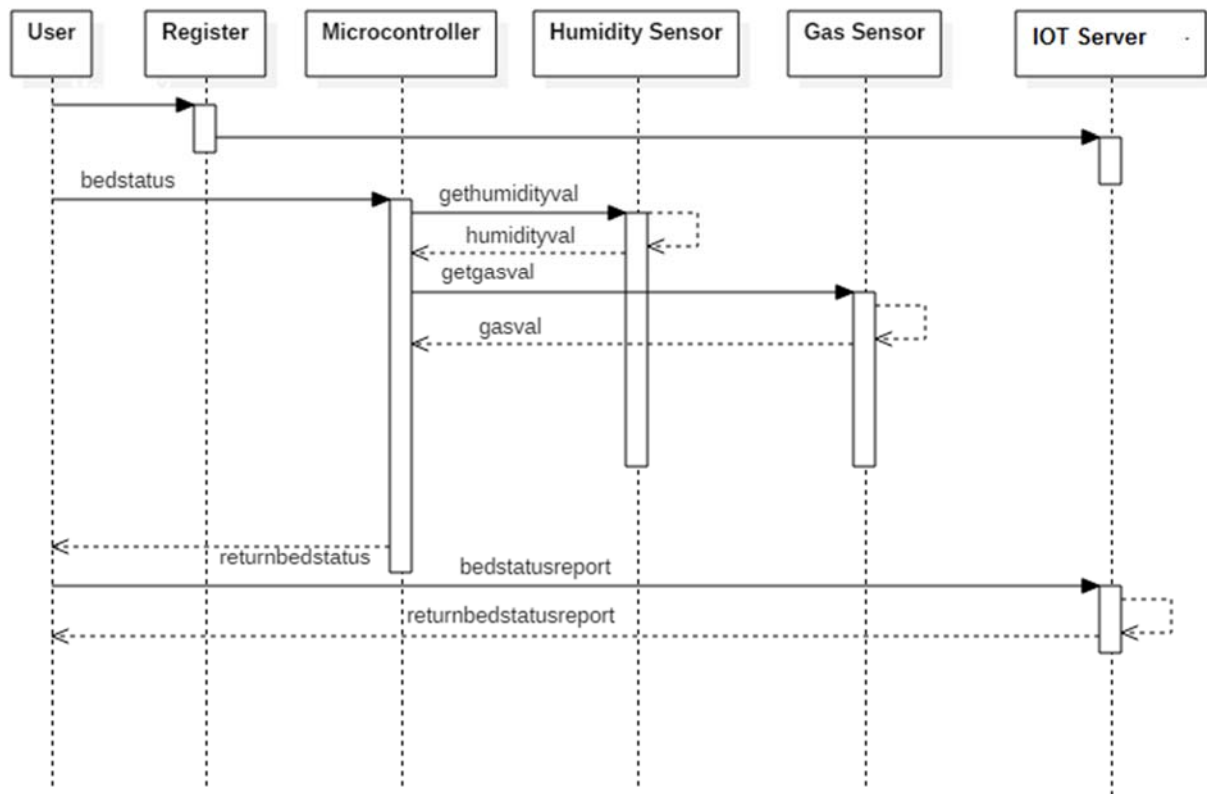

Figure 4. 4 Sequence Diagrams

## Chapter 5: Implementation and Testing

### 5.1 Introduction

This chapter looks into the implementation and testing of the soiled linen detection prototype. In this chapter, we will also delve into the devices, software development platforms, the database used, levels of system users, results and challenges faced during the implementation process. During the implementation process, there was a heavy reliance on Rapid prototyping methodology as discussed earlier in chapter 3.

#### 5.1.1 Creating Soiled Linen Definition Rules

This will be dependent on two aspects and the third will be based on observation. Table 5.1 refers to the attribute definition of the humidity and gas presence.

**Table 5. 1 : Attribute Definition**

Attribute	Instance
<b>Humidity</b>	Normal: 40-60% Abnormal above 70%
<b>Gas</b>	Normal Hydrogen Sulphide composition is under 0.001ppm values above 1 will be considered high

The following are some of the rules that were used to determine the positive detection of soiled linen. The rules were defined as functions in the Arduino IDE.

- i. IF humidity is present and is above 70% THEN Soiled
- ii. IF humidity is present and is below 70% and Gas is above 1ppm then Soiled

## 5.2 Assembling Components

The initial step was to assemble and configure the required devices hardware software and necessary centralised system to ease the implementation and testing of the prototype. The need to assemble this was to allow for proper planning and proper resource utilisation. The following describes the hardware required for the development process:

### 5.2.1 Hardware Requirements

Table 5.2 below describes the hardware requirements for the automatic soiled linen detection

**Table 5. 2: Hardware Requirements**

Hardware	Technical Specification	Description
<b>DHT11 humidity Sensor</b>	Operating Voltage: +5 V Humidity: 20-90% RH $\pm 5\%$ RH error Temperature range: 0-50 °C error of $\pm 2$ °C	This is a humidity and temperature sensor that utilises one transfer cable to transmit the data of relative humidity in the air. It has fast response, high reliability and excellent long term stability
<b>MQ136 gas sensor</b>	Concentration 0.00-10.00 ppm	The Gas Sensor (MQ136) module is useful for gas detection (home and industry). It is suitable for detecting H <sub>2</sub> S. Due to its high sensitivity and fast response time, the measurement can be taken as soon as possible.
<b>Arduino Uno Board</b>	Operating Voltage: 5V Input voltage (Recommended): 7-	A cheap and easily programmable microcontroller. It was picked for this research because of its compatibility with most sensors.

	12V. Digital I/O pins: 14 6 analog inputs, a 16MHz crystal oscillator, a USB connection, a power jack, an ICSP header and a reset button	
<b>A Solderless PCB Breadboard (Model MB-102)</b>	Dimension: 165mm x 55mm x 10mm. Wire size: Suitable for 29- 20 AWG wires	The breadboard serves as an anchor point for all the electrical device such as sensors capacitors and resistors. The breadboard enables the creation of a circuit where data transfer is made possible
<b>Jumper Cables</b>	Red, blue, black, green and yellow codes. Male to Male, Male to Female and Female to Female.	The jumper cables are used for wiring purposes.
<b>ESP8266 Wireless Module</b>	Wi-Fi Module integrated TCP/IP, 802.11 b/g/n	Transmits sensor data packets to the central system

**5.2.2 Software Requirements**

Table 5.3 describes the software components of the soiled linen detection prototype.

**Table 5. 3: Software Components**

Software	Description
<b>Operating System</b>	Microsoft Windows 10
<b>Firebase</b>	Online development application that is used to display the alerts whilst awaiting processing.
<b>Internet Browser</b>	Any internet browser. Google Chrome is Preferred
<b>Arduino IDE</b>	Arduino IDE Version 1.8.8.
<b>Firestore</b>	This is a Google and Firebase cloud platform that allows for scalable databases for mobile, web and server development in real-time.

### **5.2.3 Server Configuration**

In this study, we deployed the use of Firestore and Firebase Google cloud platform. Firestore is a utility-based cloud storage platform enables the collection and storage of data in the cloud for development of applications. It gives users options and plans for payment but also offers a free platform for users with limited data usage per month. Firestore is a NoSQL, real-time cloud storage facility provided by Google enabling instant notification of any changes to the client thus gaining on response time. Firebase, on the other hand, enables the processing of the information that is sent from the sensors to the database and design of the front end that will be used by the user in viewing processed data

Setting up of the platform required accessing of the firebase website, registering and configuring of the Firestore.

## 5.2.4 Web Page

The data received from the Arduino is sent to the database and immediately picked up on the website using the jQuery functionality reducing the need to query data periodically. The information is displayed on the website as shown in Figure 5.1 and awaits the user to click on manage so as to resolve the issue at hand.

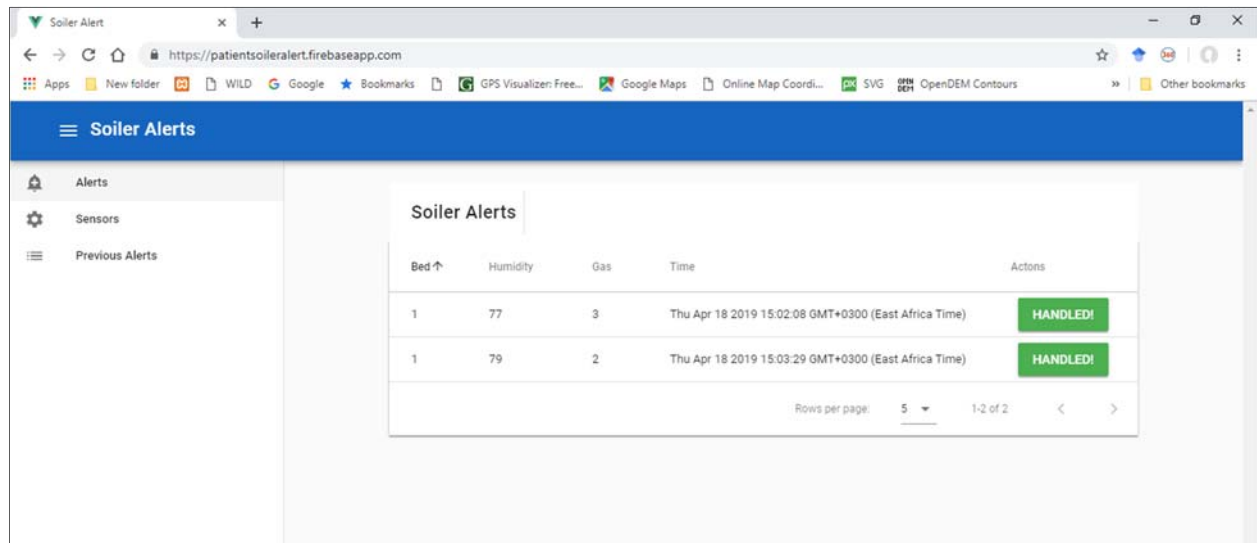

Bed ↑	Humidity	Gas	Time	Actions
1	77	3	Thu Apr 18 2019 15:02:08 GMT+0300 (East Africa Time)	HANDLED!
1	79	2	Thu Apr 18 2019 15:03:29 GMT+0300 (East Africa Time)	HANDLED!

Figure 5. 1 Soiled Linen Alert System Webpage

## 5.3 Pseudo Code

The major functionality of the prototype is to capture sensor information from the Gas and humidity sensors, processing the sensor values and thereafter relaying the information to the cloud storage via HTTPS protocol.

### 5.3.1 Software Configuration and Development Setup

The development platform was first set up and in this case, we are using the Arduino IDE (Integrated Development Environment). Arduino IDE is free and available for download from their official Arduino Website for the different operating systems available such as Windows,

MacOS and Linux. Arduino is based on C/C++ compiler (Arduino, n.d.). The implementation of this study was done on a Windows 10 platform.

Development of the prototype in the IDE platform required download and access to the addition of the required libraries such as the DHT11 library, esp8266 and MQTT library. Links were provided to where the libraries were to be retrieved and these were added through the following procedure:

- i. The DHT11 library, esp8266 and MQTT Library were downloaded from GitHub.
- ii. For each the Library they were added to the Arduino IDE by opening the IDE and clicking on the "Sketch" menu followed by Include Library > Manage Libraries
- iii. The library manager then opens a list of libraries that are already installed or ready for installation were displayed with their corresponding version numbers
- iv. The DHT11 library, esp8266 MQTT Libraries were finally located from the download location and installed

Arduino Uno Microcontroller was first set up to receive data from the sensors and thereafter to transmit the data to the Firestore cloud platform. This was done by initializing the communication pins of the Arduino, enabling software serial pins and initializing serial communication.

Communication to the Firebase cloud platform is through ESP8266 thus it was prudent to connect it using the available home wireless internet connections using the access credentials for the SSID and Password to push the values to the Firestore cloud storage platform. Figure 5.2 is the pseudocode for the communication.

```
void setup() {
  // put your setup code here, to run once:
  DEBUG=true
  Serial.begin(9600);
  pinMode(trigPin, OUTPUT);
  pinMode(echoPin, INPUT);
  Serial.begin(9600);
  espSerial.begin(115200);
  espSerial.println(1000);
  espSerial.println("AT+CWJAP=\"" + Strathmore + "\",\"" + 5strathmore "\"");
  showResponse(5000);
  if(DEBUG) Serial.println("OK@");
}
```



**Figure 5. 2 Setup Pseudo Code**

### **5.3.2 The Main Execution**

This section of code contains the void loop() function. This is the procedural execution part of the main program block. The sensor data are parsed at this point, manipulation of the data to meaningful information which is parsed to the web API server for propagation and storage. Below is a sample code figure 5.3 for humidity and gas sensor.

```

void loop()
{
  int chk = DHT.read11(DHT11_PIN);

  Serial.print("Current humidity: ");
  Serial.print(DHT.humidity);
  Serial.print("%");
  // Serial.print("temperature: ");

  //Serial.print(DHT.temperature);
  // Serial.print("°C");
  Serial.print("GAS:");

  delay(2000);
}

```

**Figure 5. 3 Main Program Pseudocode**

### 5.3.3 Push to Web API server

This is one of the last executions that the Microcontroller does as it pushes the sensor data to the Firebase cloud platform. The Esp8266 connects to the network and receives the information from the IoT module and pushes it to the cloud for processing analysis and retrievals.

The function enables the connection to the Firebase web service and is obtained before transmission is initialized. The code will be expected to return a ‘Successful Post’ or ‘Failure’, where successful is where the data has been successfully pushed to the web whilst failure implies data was not sent.

The system periodically checks the data that is to be transmitted from the sensor units to see if it meets the criteria given. If the sensor values meet the criteria set, the Push iteration will be initialised and the data will be sent to the web platform.

## 5.4 Prototype Testing

The strategy utilised for prototype testing included unit testing, Integration testing and System Usability tests. System and Integration testing were handled by the developer and the caregivers to see if it meets the requirements set, and measures to expectation in terms of usability, accuracy and responsiveness.

**Table 5. 4: Integration and System Test**

Test case Name: Integration and System Test				
Test Date: 10 <sup>th</sup> April 2019				
Test Description:				
Pre-Conditions:				
Post-Conditions:				
Step	Action	Expected Response	Pass/Fail	Comments
1.	Arduino to Web Service and mobile application Integrations	Fast and reliable push and pull integrations	PASS	Successful
2.	Server side and Web Application visualizations	Easy to identify and Simple visualizations	PASS	Successful
3.	System response time and real-time reporting	Ability to respond and publish information fast	PASS	Successful

## Chapter 6: Discussions

### 6.1 Introduction

In this chapter, the main findings from the research questions are summarised and general conclusions based on the findings of the studies presented.

### 6.2 Findings

The findings from the prototype testing results and the system usability questionnaire that was administered was summarised in table 6.1.

**Table 6. 1: System Usability Survey Findings**

	No	Yes	Other
The User Interface is friendly	22.2%	72.2%	5.56%
I can use the system with Minimum training	27.78%	61.11%	11.11%
I am willing to use this system to detect patients soiled linen	5.56%	66.67%	27.78%

#### 6.2.1 User Interface

From the survey, 72.2% of the sample population agreed that the user interface was simple and very friendly. The other 22.2% disagreed it was not user-friendly and the other 5.56 responded with other different remarks. See figure 6.1 below

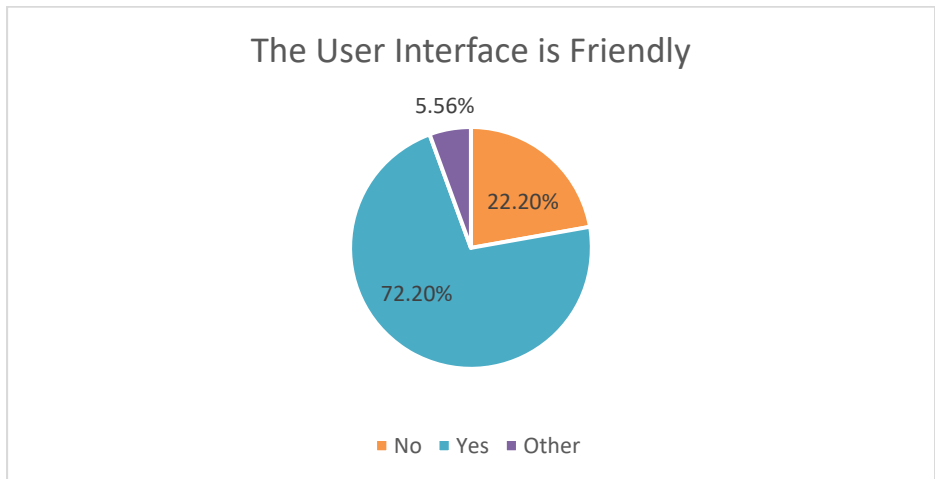

**Figure 6.1 User Interface is Friendly**

**6.2.2 Training**

In a separate survey question, 61.11% responded that they could use the system with minimum training, 27.78% disagreed mainly due to the connectivity challenge and another 11.1% were neutral. See figure 6.2 below

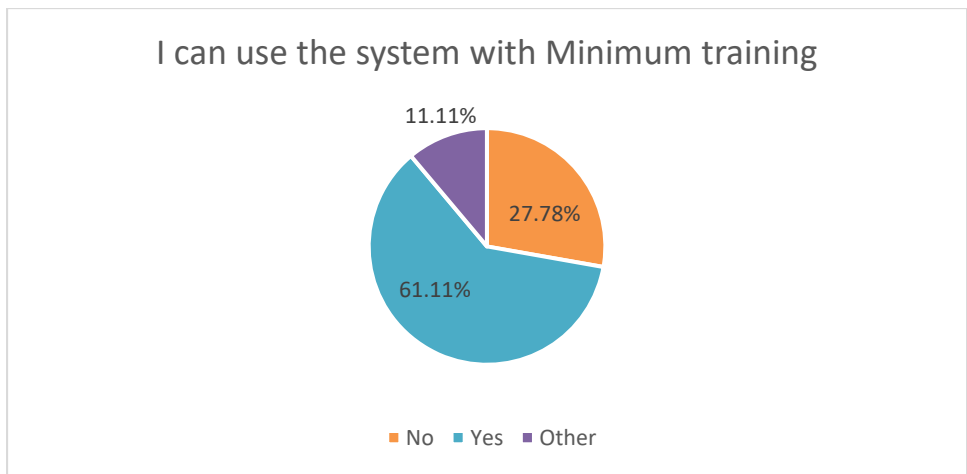

**Figure 6. 2 Minimum training required on system Use**

### 6.2.3 Acceptance

In the last survey question on system usability, 66.67% of the respondents affirmed that they are willing to use the system for detection of soiled linen, 5.56% were unwilling whilst the other 27.78% were neutral. See figure 6.3 below

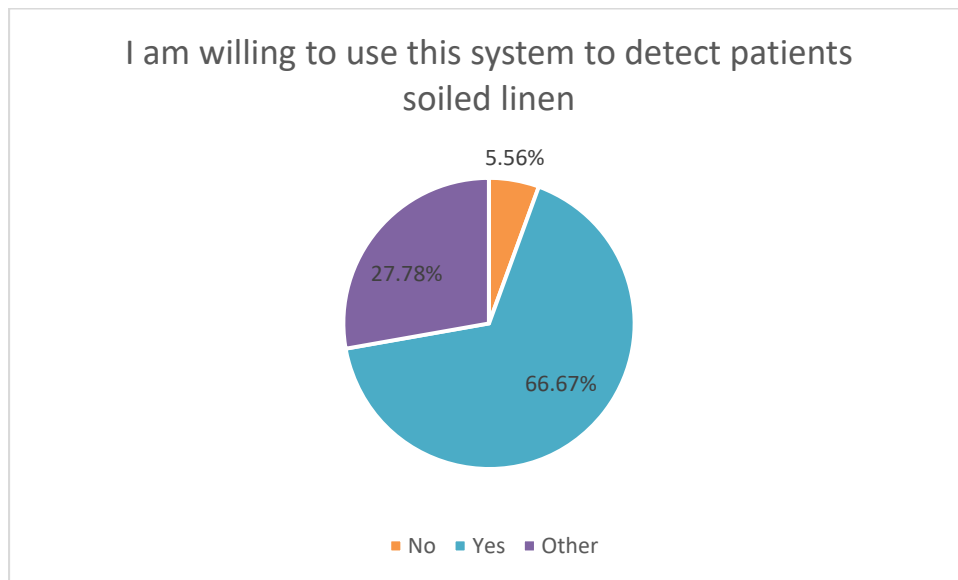

**Figure 6. 3 Willingness in System Use**

### 6.2.4 Performance

On performance, we subjected the respondents on the soiled linen detection prototype capabilities where 44.4% of the respondents strongly agreed that the soiled linen detection on hydrogen sulphide and humidity is easier and alerts are immediately received as soon as the safety levels have been exceeded. 5.56% strongly disagreed and the other 22.22% were neutral. See figure 6.4

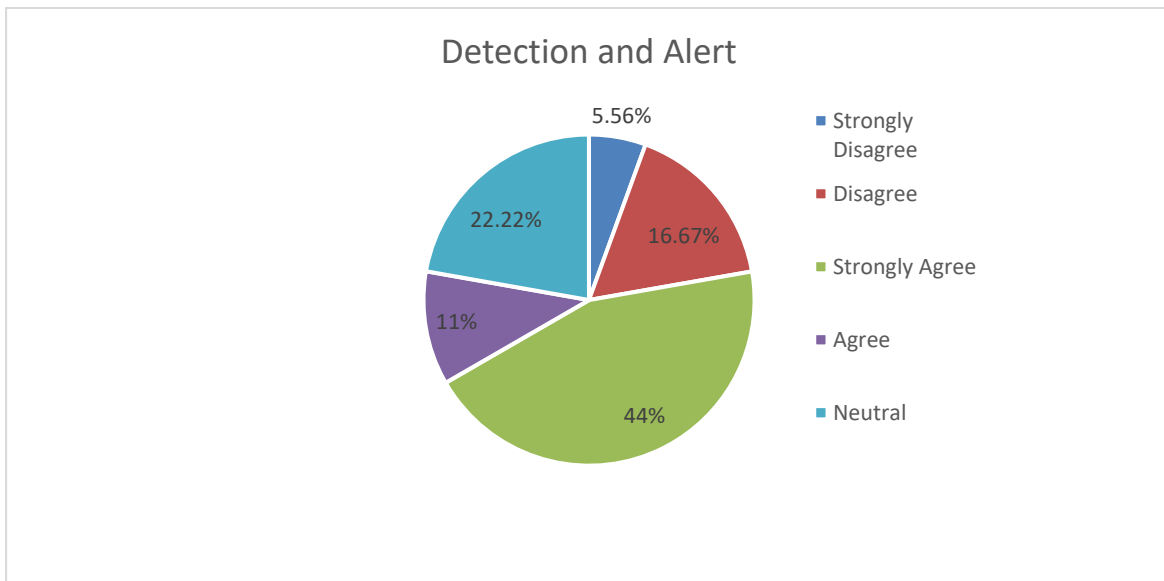

**Figure 6. 4 Easy and Fast Detection and alert**

### **6.3 Limitations of the Prototype**

The researcher noted that the success rates were based on the proper well-made beds that enabled gas and humidity content to be contained between the beddings. The DHT11 sensor could be replaced to have a larger surface area where the patient lies so as not to be limited to only one side of the bed. The second challenge is not all hospitals are internet connected especially through Wi-Fi connectivity and with this, there was a concern in regards to the need to always send an alert to the cloud storage whenever safety levels were exceeded. This concern could not be tackled as it was beyond the scope of work.

## **Chapter 7 Conclusion and Recommendation**

### **7.1 Conclusion**

Soiled linen detection has been highly dependent on manual mechanisms and the lack of an adequate alert mechanism to the caregiver leaves the patient with soiled linen at high risk. The current mechanism known as turn procedure involves manually observing, smelling or touching the patient linen.

The research utilised the use of questionnaires and in this case, the caregivers highly depended on the turn procedure and relied on manual mechanisms of detection of soiled linen, common to it all was smell test and observation. These methods were unreliable and patients were easily exposed over a long time to a harmful environment,

The research takes advantage of the availability of the IoT concept and uses algorithms to come up with a sensor-based system for detection and alerting the humidity and gas level content. The users will get a notification and upon attending to the patient set the message to handle.

### **7.2 Recommendation**

Through this study, the researcher identified that the caregivers would prefer a larger surface area sensor than what DHT11 is able to offer one whose surface area can touch both sides of the bed. Within the hospital facility, not all the beds were modern thus the prototype would require a source of power such as a battery to be attached to the prototype.

## References

- Arduino. (n.d.). Retrieved from <https://www.arduino.cc>
- Asfour, H. I., & El-Soussi, A. H. (2016). Examining bed-bath practices of critically ill patients. *Journal of Nursing Education and Practice*.
- Aucamp, M. (2016). *Housekeeping and Linen Management*. North Ireland: International Federation of Infection Control.
- Bikson, M., Cardoso, L., & Cancel, L. (2008, May 19). *Baby Diaper Wetness Detector and Indicator Biomedical Engineering Senior Design I*. Retrieved from Semantic Scholar: <https://pdfs.semanticscholar.org/385e/2aa339c6a831940e7169e7b372c31ab5f420.pdf>
- Binks, R., De Luca, E., Dierkes, C., Herrero, E., & Niederaalt, G. (2015). Prevalence, clinical consequences and management of acute faecal incontinence with diarrhoea in the ICU: The FIRST™ Observational Study. *Journal of the Intensive Care Society*, 294-301.
- Brunning, A. (2017). *The Chemistry of Bodily Fluid Colors*. Retrieved from Compound Interest: <https://www.compoundchem.com/wp-content/uploads/2017/01/The-Chemistry-of-Bodily-Fluid-Colours.png>
- Carel. (2013, January 21). Retrieved from Carel: <https://www.carel.com/documents/10191/0/%2B4000021EN/8ad03ec9-6f9f-4216-8395-b2f95325671f>
- CDC. (2017). *Innovative Research to Support Safe Healthcare*. Atlanta: Center of Disease Control.
- Clancy, J., & McVicar, A. (2009). *Physiology and Anatomy for Nurses and Healthcare Practitioners*. Florida: CRC Press.
- Dean, J. R. (2016). Identifying the chemicals that make clothing smell could improve the washing process. *ELSEVIER*.

- EFSA . (2010). Scientific Opinion on Dietary Reference Values for water1 . *EFSA journal*, 1459-1507.
- Ellen, S. (2018, May 29). *Slovin's Formula Sampling Techniques*. Retrieved from Sciencing: <https://sciencing.com/slovins-formula-sampling-techniques-5475547.html>
- Garfoot, A., & Knock, A. (2017, November). *Linen and Laundry Management Policy*. Retrieved from Leicestershire Partnership NHS Trust: <http://www.leicspart.nhs.uk/Library/LinenandLaundryManagementPolicyexpJan20.pdf>
- Grandjean, A. (2004). *Water Requirements, Impinging Factors, and Recommended Intakes* . Geneva: World Health Organisation.
- Huadong, W., & Siegel, M. (2000). Odor-Based Incontinence Sensor . *IEEE Instrumentation and Measurement* .
- James, S., & Skinner, G. (2011). Management by Numbers. *ALM Journal Online*, 18-19.
- Jocelyn, C. H.-S., Thiara, E., Lopez, V., & Shorey, S. (2017). Turning frequency in adult bedridden patients to prevent hospital-acquired pressure ulcer: A scoping review. *International Wound Journal*, 1-12.
- Khatri, M. (2018, February 25). *Incontinence & Overactive Bladder*. Retrieved from WebMD: <https://www.webmd.com/urinary-incontinence-oab/truth-about-urine>
- KNH. (2017). *ANNUAL REPORT AND FINANCIAL STATEMENTS FOR THE YEAR ENDED JUNE 30, 2017*. Nairobi.
- KNH. (2017, January 24). *History:KNH*. Retrieved from KNH: <http://knh.or.ke/index.php/history/>
- Kumar, P. N., Sujith, K., Vignesh, & Shivakumar. (2016). Study On Linen Costs and Utilisation in A Tertiary Care Hospital. *Research Journal of Pharmaceutical, Biological and Chemical Sciences*, 1130-1135.

Mall, R. (2018). *Fundamentals of Software Engineering*. Delhi: PHI Learning Private Limited.

Ministry Of Public Health And Sanitation, Ministry of Medical Services. (2010). *National Infection Prevention and Control Guidelines for Health Care Services in Kenya*. Retrieved from Ashcott: [http://www.ashcott.com/images/IPC\\_GUIDELINES.pdf](http://www.ashcott.com/images/IPC_GUIDELINES.pdf)

Picco, M. F. (2019, February 29). *Stool Color: When to worry*. Retrieved from Mayo Clinic: <https://www.mayoclinic.org/stool-color/expert-answers/faq-20058080>

Rentokil. (n.d.). *What is Body Fluid: Rentokil Specialist Hygiene*. Retrieved from Rentokil-hygiene.co.uk: <https://www.rentokil-hygiene.co.uk/specialist-disinfection/biohazard-cleaning/what-is-body-fluid/>

Sharma, D. S. (2017). Quality Assurance Hospital Linen and Laundry Services. *International Journal of Science and Research (IJSR)*, 593-596.

Shiel, W. C. (2018, April 12). *Medical Definition of Bile*. Retrieved from MedicineNet: <https://www.medicinenet.com/script/main/art.asp?articlekey=2459>

Shu, C. (2016). *Monit's smart diaper sensor that lets parents avoid the sniff test*. Retrieved from techcrunch: <https://techcrunch.com/2017/04/30/monit/>

UK Department of Health. (2016, March). Decontamination of linen for health and social care. *Health Technical Memorandum 01-04*: . London, United Kingdom: Crown.

VRPA Technologies. (2010). *Kern River Valley Specific Plan – Air Quality Impact Assessment* . Los Angeles.

WebMD . (2018, October 20). *WebMD Medical Reference: Bed-wetting Alarms*. Retrieved from WebMD Medical Reference: <https://www.webmd.com/parenting/how-bed-wetting-alarms-work#1>

WHO. (2018, November 23). *Nurses and Midwives (per 1,000 people)*. Retrieved from The World Bank: Data: <https://data.worldbank.org/indicator/SH.MED.NUMW.P3?locations=KE>

wood, J. (2004). *Agile and Iterative Development: A Manager's Guide. Communication*. Boston: Addison-Wesley.

Woolston, C. (2019, January 1). *Caregiving: Bedpans, Portable Commodes, and Other Options*. Retrieved from Aging Health Library: <https://consumer.healthday.com/encyclopedia/aging-1/misc-aging-news-10/caregiving-bedpans-portable-commodes-and-other-options-643599.html>

## Appendices

### Appendix A: Turnitin Similarity index.

The screenshot shows a Turnitin Match Overview report. The document title is "An Automatic Soiled Linen Detection Prototype for Hospital Ward Caregivers" by James Akumonyo. The overall similarity index is 12%. The report lists seven matches with their respective sources and similarity percentages.

Rank	Source	Similarity
1	edoc.site Internet Source	2%
2	Submitted to Strathmor... Student Paper	2%
3	www.rentokil-hygiene.c... Internet Source	<1%
4	Jetendra Joshi, Akshay... Publication	<1%
5	essay.utwente.nl Internet Source	<1%
6	Submitted to University... Student Paper	<1%
7	Chamila J. Denawaka, I... ...	<1%

## Appendix B: User Requirements Questionnaire

### User Requirements Questionnaire

**Researcher:** James Lidonde Akumonyo

MSc.IT, Strathmore University

This survey will be used for academic purposes only. Its main objective is to collect the user requirements to create an automatic soiled linen detection prototype for hospital ward caregivers. Kindly provide your honest answers to the following questions. Please note that your answers will be treated as private and confidential and will be used for this study only.

1. What is your department of work? .....
2. Soiled linen is easily detected using gas and humidity level?
  - Strongly Agree
  - Agree
  - Neutral
  - Disagree
  - Strongly Disagree
3. The current method of soiled linen detection is efficient
  - Strongly Agree
  - Agree
  - Neutral
  - Disagree
  - Strongly Disagree
4. The caregivers are promptly alerted upon patients soiling of linen?
  - Strongly Agree
  - Agree
  - Neutral

- Disagree
  - Strongly Disagree
5. The current system allows for checking soiled linen status is user-friendly?
- Strongly Agree
  - Agree
  - Neutral
  - Disagree
  - Strongly Disagree
6. The current process and system for soiled linen detection provides dashboards and reports for management to monitor soiled linen patterns?
- Strongly Agree
  - Agree
  - Neutral
  - Disagree
  - Strongly Disagree
7. The current system allows caregivers to check soiled linen bed status at any time?
- Strongly Agree
  - Agree
  - Neutral
  - Disagree
  - Strongly Disagree
8. I believe the current systems and processes, if any, for bin monitoring are secure and the data is safely kept?
- Strongly Agree
  - Agree
  - Neutral
  - Disagree
  - Strongly Disagree

9. If a proper computer system is implemented, I believe that soiled linen detection would be made easier?

- Strongly Agree
- Agree
- Neutral
- Disagree
- Strongly Disagree

## Appendix C: System Usability Questionnaire

### System Usability Questionnaire

**Researcher:** James Lidonde Akumonyo

MSc. IT, Strathmore University

This research will be used for academic purposes only. Its main objective is to collect the user experience when using the Automatic Soiled Linen Detection Prototype for Hospital Ward Caregivers. Kindly provide your honest answers to the following questions. Please note that your answers will be treated as private and confidential and will be used for this study only.

1. The User interface is user-friendly?

- Strongly Agree
- Agree
- Neutral
- Disagree
- Strongly Disagree

2. I can use the prototype with minimum training?

- Strongly Agree
- Agree
- Neutral
- Disagree
- Strongly Disagree

3. Detection of gas emission and humidity is easier and takes shorter duration as compared to current methods?

- Strongly Agree
- Agree
- Neutral

- Disagree
  - Strongly Disagree
4. The system provides a convenient way of monitoring soiled linen bed status
- Strongly Agree
  - Agree
  - Neutral
  - Disagree
  - Strongly Disagree
5. I am willing to use this system for detecting soiled linen?
- Strongly Agree
  - Agree
  - Neutral
  - Disagree
  - Strongly Disagree
6. How likely are you to recommend this system to other users?
- Strongly Agree
  - Agree
  - Neutral
  - Disagree
  - Strongly Disagree
7. Any other comments
- .....
- .....
- .....
- .....
- .....
- .....



## Appendix E: Serial Monitor readings from MQ2 and DHT11 sensor

The image shows the Arduino IDE interface with a sketch named 'DHT11\_MQ2' and a serial monitor window titled 'COM6'. The sketch code is as follows:

```
DHT11_MQ2
// ...
Serial.print("Current humidity: ");
Serial.print(DHT.humidity);
Serial.print("% ");
// Serial.print("temperature: ");

//Serial.print(DHT.temperature);
// Serial.print("°C ");
Serial.print("GAS:");
// Serial.print("LPG:");
Serial.print(MQGetGasPercentage(MQRead(MQ_PIN)/Ro,GAS_LPG) );
// Serial.print(" ppm");
//Serial.print(" ");
//Serial.print("GAS:");
//Serial.print(MQGetGasPercentage(MQRead(MQ_PIN)/Ro,GAS_CO) );
Serial.print(" ppm");
Serial.print(" ");
//Serial.print("SMOKE:");
// Serial.print(MQGetGasPercentage(MQRead(MQ_PIN)/Ro,GAS_SMOKE) );
//Serial.print(" ppm");
Serial.print("\n");
// lcd.setCursor(0, 0);
// lcd.print("LPG:");
//lcd.print(MQGetGasPercentage(MQRead(MQ_PIN)/Ro,GAS_LPG) );
////lcd.print(" ppm");
//lcd.print(" ");
//lcd.setCursor(9, 0);
//lcd.print("CO:");
```

The serial monitor displays the following output:

```
Current humidity: 59.00% GAS:19ppm
Current humidity: 59.00% GAS:19ppm
Current humidity: 59.00% GAS:19ppm
Current humidity: 60.00% GAS:19ppm
Current humidity: 59.00% GAS:21ppm
Current humidity: 60.00% GAS:24ppm
Current humidity: 60.00% GAS:19ppm
Current humidity: 60.00% GAS:24ppm
Current humidity: 60.00% GAS:17ppm
Current humidity: 60.00% GAS:17ppm
Current humidity: 60.00% GAS:19ppm
Current humidity: 59.00% GAS:17ppm
Current humidity: 59.00% GAS:19ppm
Current humidity: 59.00% GAS:19ppm
Current humidity: 59.00% GAS:19ppm
Current humidity: 59.00% GAS:17ppm
Current humidity: 59.00% GAS:15ppm
Current humidity: 59.00% GAS:17ppm
Current humidity: 59.00% GAS:17ppm
Current humidity: 59.00% GAS:17ppm
Current humidity: 59.00% GAS:15ppm
Current humidity: 59.00% GAS:15ppm
Current humidity: 59.00% GAS:17ppm
Current humidity: 59.00% GAS:17ppm
Current humidity: 59.00% GAS:19ppm
Current humidity: 59.00% GAS:19ppm
Current humidity: 59.00% GAS:19ppm
Current humidity: 59.00% GAS:19ppm
Current humidity: 59.00% GAS:15ppm
Current humidity: 59.00% GAS:15ppm
Current humidity: 59.00% GAS:17ppm
Current humidity: 59.00% GAS:19ppm
Current humidity: 59.00% GAS:19ppm
Current humidity: 59.00% GAS:19ppm
```

The IDE status bar at the bottom indicates: 76 Arduino/Genuino Uno on COM6. The serial monitor settings are: Autoscroll, Show timestamp, Both NL & CR, 9600 baud, and Clear output.

