



STRATHMORE UNIVERSITY
SCHOOL OF COMPUTING AND ENGINEERING SCIENCES
Bachelor of Electrical Engineering
Final Examination
BEE 2103: STATICS AND DYNAMICS

DATE: 1st August 2022

TIME: 3 HOURS

Instruction: Answer question one and any two other questions.

I. (Kinetics, Resolution of Forces and Equivalent System of Forces)

QUESTION ONE

a) A basketball is dropped from height h_0 onto a horizontal surface, modeled as a massive (i.e., immobile), smooth, horizontal surface. The trajectory of the ball is depicted schematically in Fig. 1, which shows the ball height as a function of time for the first few collisions. The ball is modeled as a particle, and vertical motion only is considered in the analysis

Assumptions:

Aerodynamic resistance is neglected, the flight time from the top of the trajectory to the surface is then half of the total flight time, T_n , between the n th and $(n+1)$ th bounce

The vertical speed v_n (i.e., the vertical component of the velocity) of the ball associated with its n th bounce is where n is number of bounces and g is gravitational acceleration.

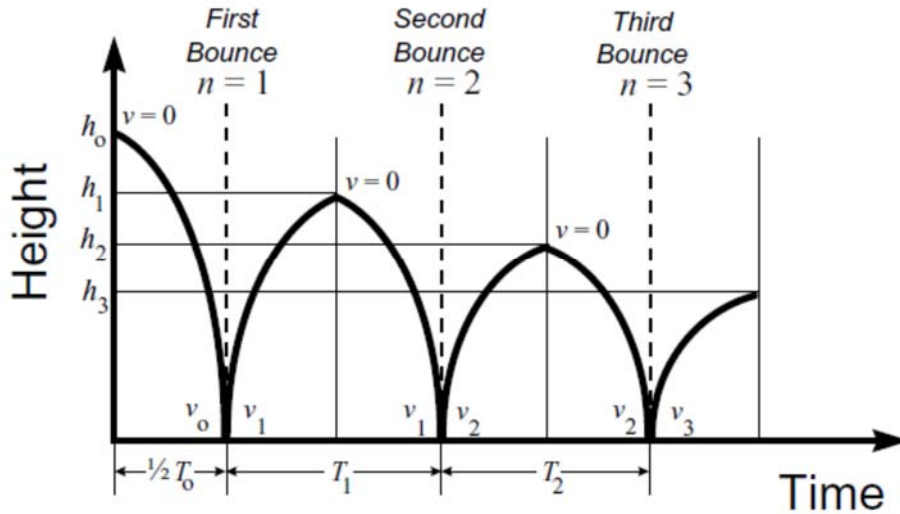

Where e is the coefficient of restitution

i) Using the data below plot an appropriate graph to determine coefficient of restitution. [5 Marks]

Number of bounce (n)	Time in mins
1	0.43
2	0.44
3	0.38
4	0.33
5	0.32
6	0.31
7	0.3
8	0.28
9	0.26
10	0.25

ii) Determine the initial velocity (v_0) of the ball and the successive velocities for each of the bounces. [4 Marks]

iii) Determine the corresponding heights of flight for each of the bounces. Comment on the values of heights. [4 Marks]

iv) If the mass of the basketball is 0.624kg determine the energy loss in each of successive bounces. [2 Marks]

b) The bracket is subjected to the two forces shown.

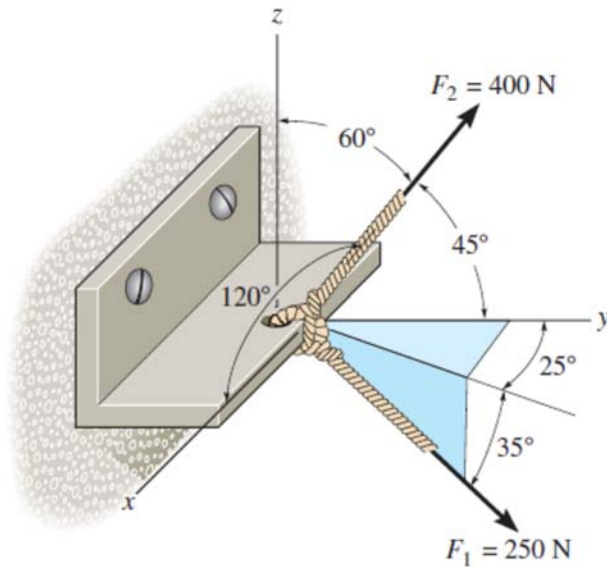

- i) Express each force in Cartesian vector form **[5 Marks]**
- ii) Determine the resultant force F_R . **[2 Marks]**
- iii) Find the magnitude and coordinate direction angles of the resultant force. **[3 Marks]**

c) Three control rods attached to a lever ABC exert on it the forces shown.

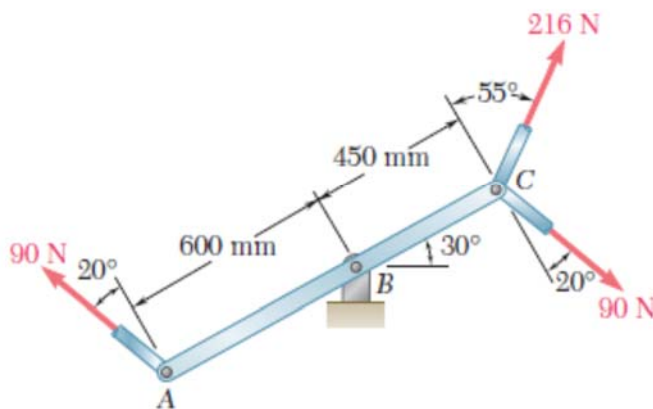

- (i) Replace the three forces with an equivalent force couple system at B . **[2 Marks]**
- (ii) Determine the single force that is equivalent to the force-couple system obtained in part i, and specify its point of application on the lever. **[3 Marks]**

QUESTION TWO (Equilibrium of Rigid Bodies. Equivalent Moments)

a) A 200-N force is applied as shown to the bracket ABC . Determine the moment of the force about A . [5 Marks]

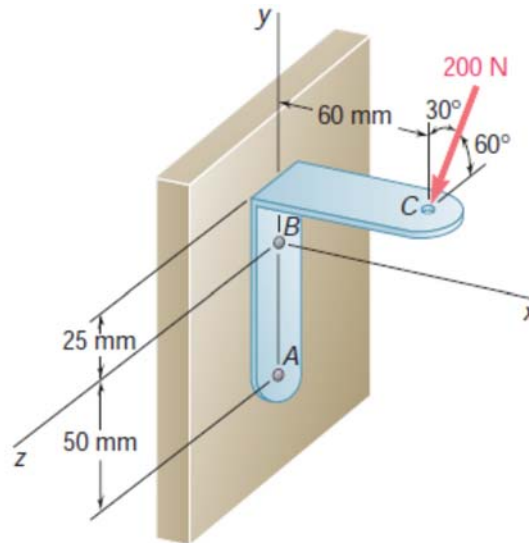

b) The force of $F = 30$ N acts on the bracket as shown

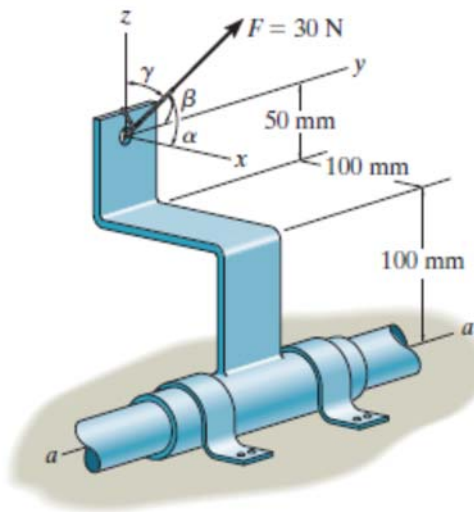

i) Determine the moment of the force about the $a-a$ axis of the pipe if $\alpha = 60^\circ$, $\beta = 60^\circ$, and $\gamma = 45^\circ$ [3 Marks]

ii) Determine the coordinate direction angles of F in order to produce the maximum moment about the $a-a$ axis. What is this moment? [3 Marks]

c) The uniform smooth rod shown in figure below is subjected to a force and couple moment. If the rod is supported at A by a smooth wall and at B and C either at the top or bottom by rollers, determine the reactions at these supports. Neglect the weight of the rod. [4 Marks]

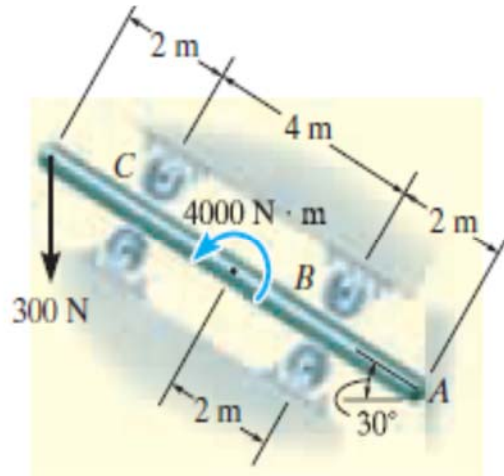

Question Three (Kinetics, Kinematics)

a) A box slides down the slope described by the equation [4 Marks]

$$y = (0.05x^2) \text{ m,}$$

$$v_x = -3 \text{ m/s, } a_x = -1.5 \text{ m/s}^2 \text{ at } x = 5 \text{ m.}$$

Find the y components of the velocity and the acceleration of the box at $x = 5 \text{ m}$

b) The crate has a mass of 120 kg, and the coefficients of friction between it and the sloping dock are $\mu_s = 0.6$. The crate starts from rest, and the winch exerts a tension $T = 1220 \text{ N}$. [4 Marks]

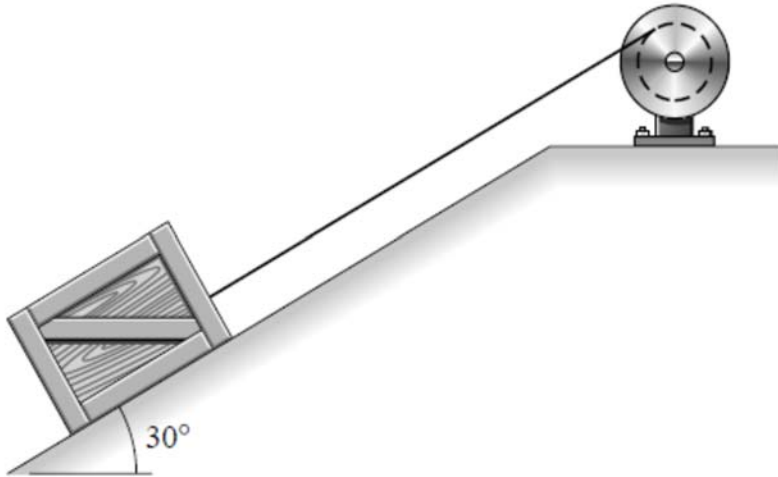

i) What impulse is applied to the crate during the first second in (s) of motion?

ii) What is the crate's velocity after 1 s?

c) The cliff divers must time their dives that they enter the water at the crest (high point) of a wave. The crests of the waves are 1 m above the mean water depth $h = 4$ m. The horizontal velocity of the waves is equal to \sqrt{gh} . The diver's aiming point is 2 m out from the base of the cliff. Assume that his velocity is horizontal when he begins the dive.

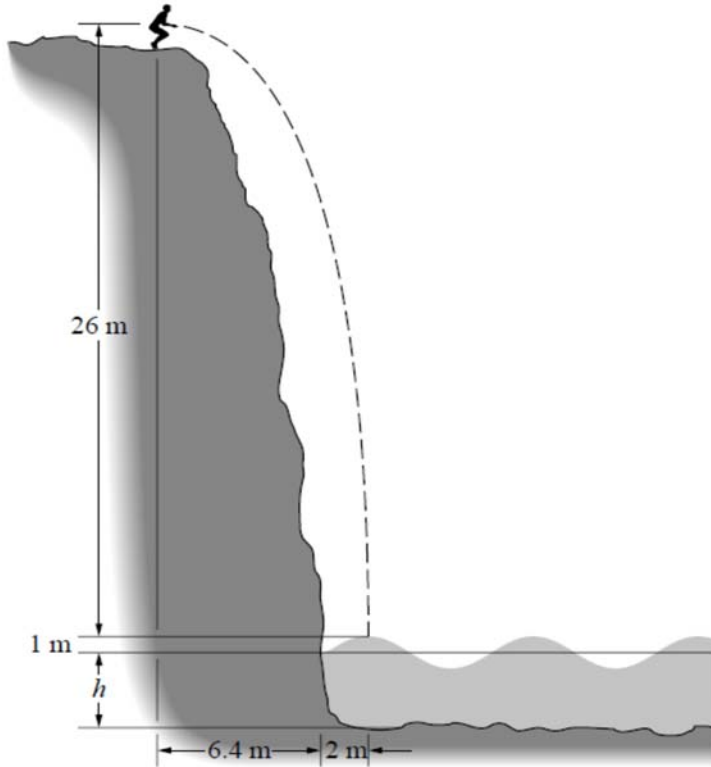

- i) What is the magnitude of the driver's velocity when he enters the water? **[4 Marks]**
- (ii) How far from his aiming point must a wave crest be when he dives in order for him to enter the water at the crest? **[3 Marks]**

Question Four (Analysis of Structures, Forces on Cables)

- a) The cable of a suspension bridge supports half of the uniform road surface between the two towers at A and B , figure below. If this distributed loading is $w_0 = 1814 \text{ kg/m}$, determine the maximum force developed in the cable and the cable's required length. The span length $L = 1280 \text{ m}$ and sag $h = 150 \text{ m}$. **[9 Marks]**

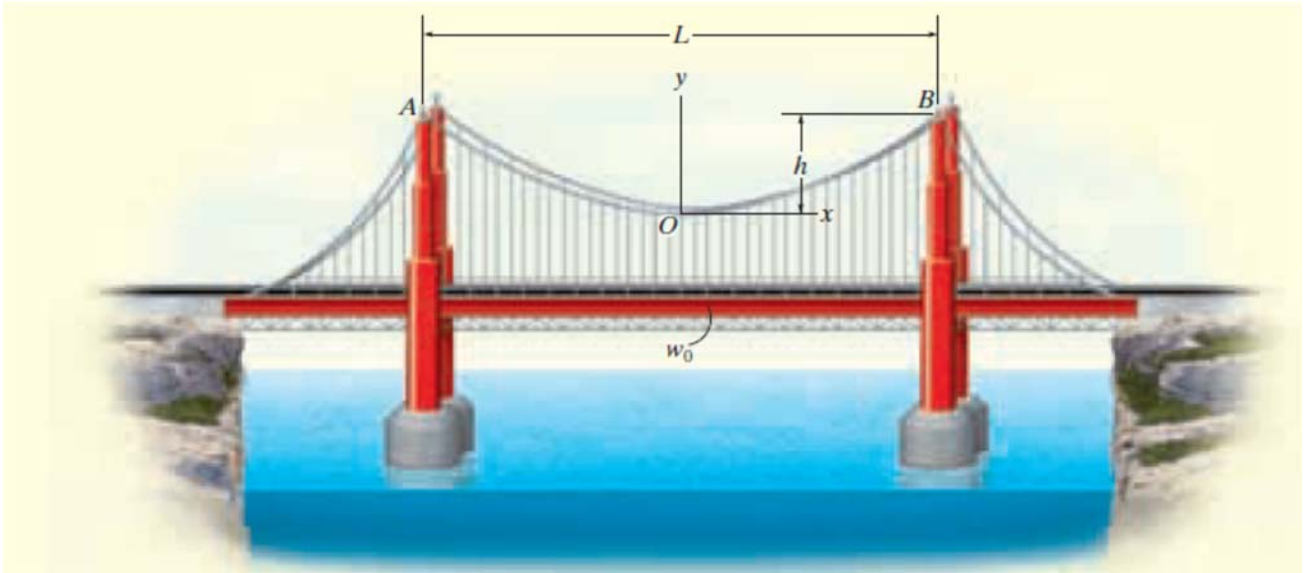

b) The portion of truss shown represents the upper part of a power transmission line tower. For the given loading, determine the force in each of the members located above HJ . State whether each member is in tension or compression [6 Marks]

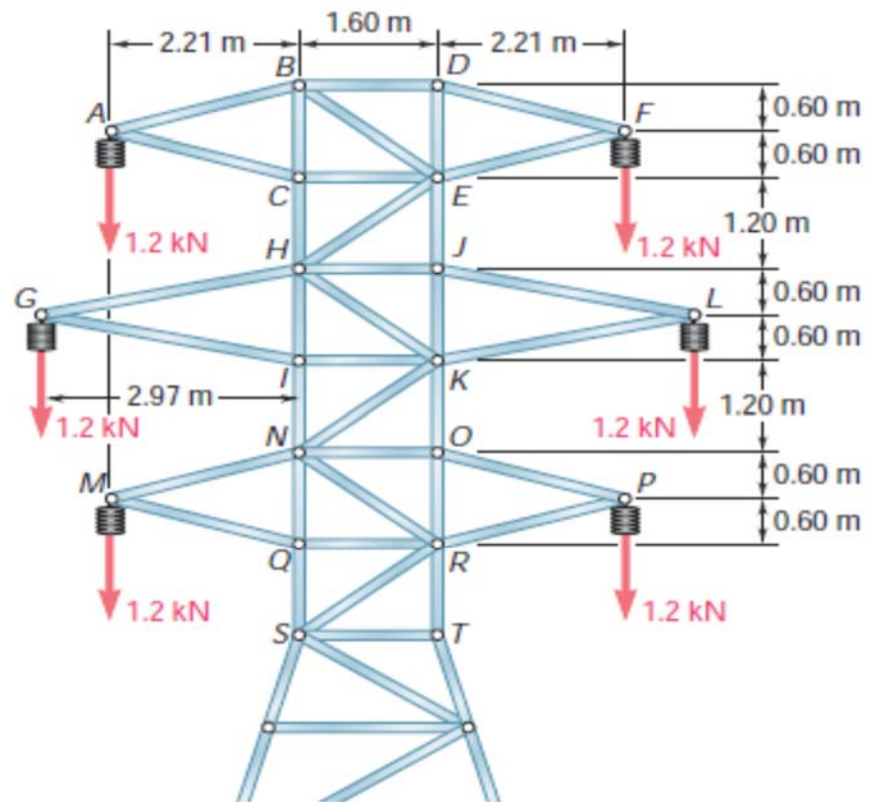

Question Five (Stress and Strain)

A tension test was performed on a steel specimen having an original diameter of 12.5 mm and gauge length of 50 mm. The data is listed in the table. **[11 Marks]**

Load (kN)	Elongation (mm)
0	0
7.0	0.0125
21.0	0.0375
36.0	0.0625
50.0	0.0875
53.0	0.125
53.0	0.2
54.0	0.5
75.0	1.0
90.0	2.5
97.0	7.0
87.8	10.0
83.3	11.5

Plot the stress–strain diagram and determine approximately the modulus of elasticity, the yield stress, the ultimate stress, and the rupture stress. Use a scale of 25 mm = 140 MPa and 25 mm = 0.05 mm/mm.

b) A bar having a length of 125 mm and cross-sectional area of 437.5 mm² is subjected to an axial force of 40 kN. If the bar stretches 0.05 mm, determine the modulus of elasticity of the material. The material has linear-elastic behavior. **[4 Marks]**

