

# ANALYSIS OF INDUCTION GENERATOR CONTROLLER TECHNIQUES FOR PICO HYDROPOWER A CASE STUDY OF A 3kW PICO HYDROPOWER SCHEME IN KASESE, WESTERN UGANDA

Teddy Nalubega<sup>1</sup> Prof.Da Silva Izael<sup>2</sup>, Assoc. Prof Okou Richard<sup>3</sup>,Abbo Mary Suzan<sup>4</sup>

Makerere University, Centre for Research in Energy and Energy Conservation, P.O. Box 7062, Kampala, Uganda<sup>1,4</sup>.Strathmore University, Strathmore Energy Research Centre, Madaraka Estate, Ole Sangale Road, P.O. Box 59857, 00200 City Square, Nairobi, Kenya<sup>2</sup>,Makerere University, Department of Electrical and Computer Engineering, Design, Art and Technology (CEDAT), P.O. Box 7062, Kampala, Uganda

**Abstract** – This paper presents a comparative analysis of control techniques used on induction generators for stand-alone Pico hydropower schemes. The techniques were tested on a prototype Pico hydropower system modeled for the site developed in western Uganda by the Centre for Research in Energy and Energy Conservation. The case study scheme to date is manually operated, a process that requires constant attention due to variations in load. This demonstrated the need for an automatic load controller. The site specifications were considered when designing models using Matlab simulink employing the automatic load control techniques. These model designs are simple so that it is affordable for local practical application. The proposed designed control techniques presented in this paper are composed of logic gates, IGBT switch, uncontrolled diode rectifier, the PID controller and other semiconductor devices supplying an electrical load and a ballast load. In addition, the response of the case study site and the Matlab model to load variations is presented. **Key Terms** - Matlab IG model, Electrical load controller, Stand-alone Pico hydropower development, RMS site performance.

## 1. INTRODUCTION

Development of Pico hydropower in off-grid areas for rural electricity access and economic growth is one of the goals to improve on the standards of living by international bodies such the World Bank and funding from EU and these support in the attainment of the millennium development goals. These schemes developed in a decentralized manner yield better economic and livelihood impact on society. These have been promoted [1] and proven more economical than grid extension for no need of transmission costs. The advancements in development of these Pico hydropower schemes have opted for more available, reliable, robust, easily maintained and affordable

SEIG presented with appropriate control systems for effective operation [2-6]. Although these have poor voltage regulation [7-8], various papers by researchers show proper functionality of the schemes with proposed designs of electronic load controllers [9-18]. The coupled controllers however need to be affordable for developers and the transient response resulting from load change need to be within acceptable limits for such a controller to be effective. This paper presents the analysis of the performance of two load control designs for a 3kW Pico hydropower scheme modeled using Matlab feeding a typical variable load profile and the performance of the case study site at the RMS 3kW Pico site with a manual load controller is also presented.

## 2. ENERGY SITUATION IN UGANDA

In Uganda, the main resource for electricity generation is hydropower with a very low electrification rate of 12% at national level but only 5% - 6% in rural areas [19], and nearly all from the big hydropower plants. SHPs projects with capacities ranging from 1MW to 20MW received a push under the Global Energy Transfer Feed-in-tariff (GET FIT) program to address the short term to medium term generation requirement to add a total of about 150MW to the total generated power of Uganda three years from October 2013[20]. These and similar government initiatives do not include projects below one mega Watt and therefore very little interest in the lowest of kiloWatts. Micro-hydro power plants configured into decentralized village-scale or county-scale mini-grids serve well in increasing electricity access within society but these had not picked much attention in Uganda other than by the private sector. This has been proven at Thima, Kirinyaga District in Kenya supplying 160 households [21], in Chembu village in Coorg District of [22], in Sri Lanka and in Nepal to supply electricity to thousands of rural households [23]. The World Bank funded the RMS site under the Energy for Rural Transformation

program under Private sector foundation Uganda to demonstrate the impact of these hydro schemes within the country.

Pico hydropower systems (capacity of up to 5kW) have a great potential in Uganda especially for off-grid decentralized energy systems. Small hydropower (SHP) schemes have a potential of 210 MW [24] that can be used to provide electricity to rural communities for productive use and for applications such as lighting, battery charging and refrigeration. This potential of 210MW is without the contribution of Pico hydropower systems in Uganda given that much attention has been given to these in the energy sector. This energy provision small as it seems improves on the livelihood of people in rural areas whose demand is limited to mainly lighting and few business enterprises

It is important also to note that the main challenge is not only the proof of technology but also the sustainability of these schemes after installation for the case of Uganda. Some of the sites that were installed years earlier failed after a short period of operation and this was a result of lack of local capacity to keep them running, replacing the spare parts and poor maintenance of the schemes which are very important aspects of sustainability of hydropower projects. The prospects of having a design of such an automatic controller for the Pico hydropower schemes which could be easily supplied locally is highly required such that these can be locally supplied, maintained and hence sustainability of power supply in the decentralized areas.

## 2.2 PICO HYDROPOWER SCHEME AT RMS

This Pico hydropower scheme is located along the Rwenzori Mountains at Kasese district in the western part of Uganda. Kasese is about 400km from Kampala and the site is located in Nyakaringijo village about 40 km from Kasese town accessible using a murrum road. The RMS has a Camp with Cottages for tourists and despite the suitable topography; there was no reliable source of electricity within the Camp and surrounding areas other than a small diesel generator supplying electricity for lighting the Camp just for few hours at night. But because river Kyabaruli a tributary of river Mubuku near the Camp a possibility of generating electricity was sought.

The project funded by PSFU under the Energy for Rural transformation (ERT) project is installed with a locally manufactured crossflow turbine, and an induction generator form Dar es salaam University. The feasibility study for this site and site implementation was supervised by CREEC.

### Site design specifications

- Design power: 3kW
- Net Head of 10m
- Design flow measurements: 50 l/s.
- Turbine Type: Crossflow
- Generator: Induction generator rated 720 rpm
- Scheme Type: Run-off-River
- Load control: manual with air fans for a ballast

## 3. MATLAB MODEL DESIGN

Using Matlab R2011a simulink, the required model components were selected for the scheme design simulation and reference to literature[2-18, 21]for calculations. These blocks such as the induction machine and loads were selected from Matlab simulink library. The two control technique models developed for the model ensure a near constant load as seen by the generator. One uses logic gates and the other the PID controller as key devices.

### 3.1 Model 1: Logic gates sensing

This model used the following truth table to control the load variation and changes. The loads were designed within three circuits. The logic gates sensors switched ON and OFF depending on the state of the load thereby maintaining a constant load on the generator.

$L_n$  – Primary Load,  $G_n$ - Gate Drive and  $D_n$ -Dump load (n representing a number of the load = 1, 2 &3); T- period of time

Primary load state 1=ON, 0=OFF				AND gateinputs			NOT gate			State for dump load		
T	L 1	L 2	L 3	G 1	G 2	G 3	G 1	G 2	G 3	D 1	D 2	D 3
1	0	0	0	0, 0, 0	0, 0, 0	0, 0, 0	I	I	I	1	1	1
2	I	0	0	I, I, I	0, 0, 0	0, 0, 0	0	I	I	0	1	1
3	I	I	0	I, I, I	I, I, 0	0, 0, 0	0	0	I	0	0	0
4	I	I	I	I, I, I	I, I, I	I, I, I	0	0	0	0	0	0
5	I	I	I	I, I, I	I, I, I	I, I, I	0	0	0	0	0	0
6	0	0	0	0, 0, 0	0, 0, 0	0, 0, 0	I	I	I	1	1	1

**Table 1: Logic gate control truth table for a variable load operation**

The truth tables shows that the model made use of the AND and NOT logic gates for the load switching.

The figures below show the models that were run and the scopes displayed the voltage, current, frequency and load change performance of the design.

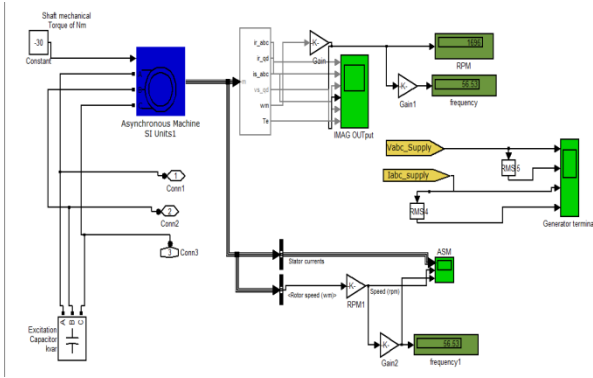

Figure 1: Induction generator model

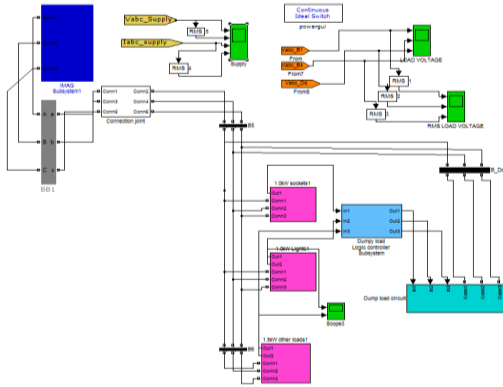

Figure 2: IG with the logic load model

### 3.2 Model 2: Constant power control

This model operates on a principle of maintaining a near constant power at the terminals of the IG. The power difference is sensed by the PID controller and registered as an error as input to a pulse generator. The pulses generated then control the switching variations of the dump load. The power difference (error) is the difference between the connected power<sub>load</sub> at that instant and the reference power (site/plant power capacity). The load and generator parameters are similar to the ones in the first model.

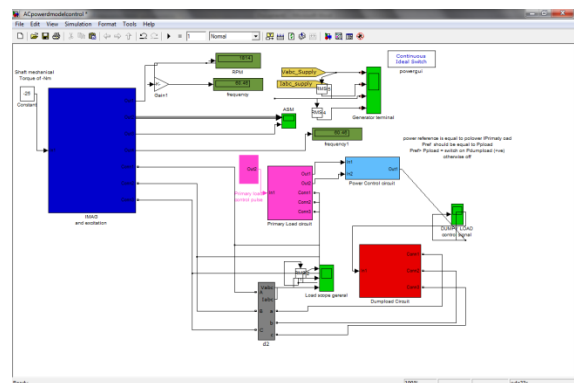

Figure 31: Power error control model

The PID controller and the circuitry was as shown in the figure 4 below.

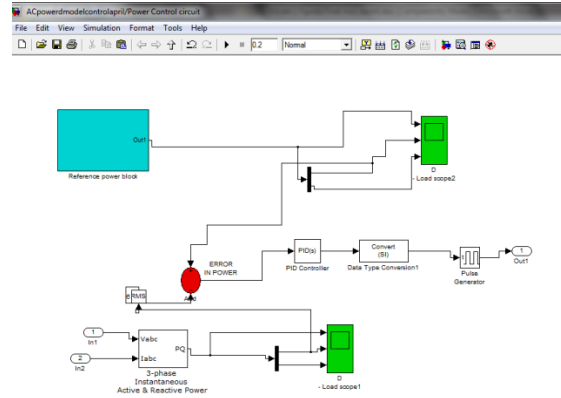

Figure 42: Error calculation and PID controller

## 4. RESULTS FROM THE MODEL AND CASE STUDY SITE

### 4.1 Results for model 1

The figures below show the scope performance of model 1 for voltage, frequency and current. These are for the scopes for the generator (figure 5&6) and at the load terminal.

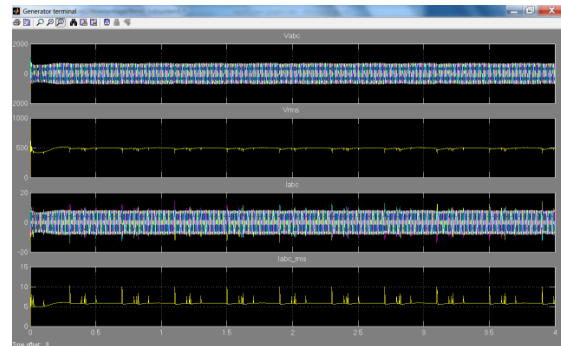

Figure 5: Induction generator output

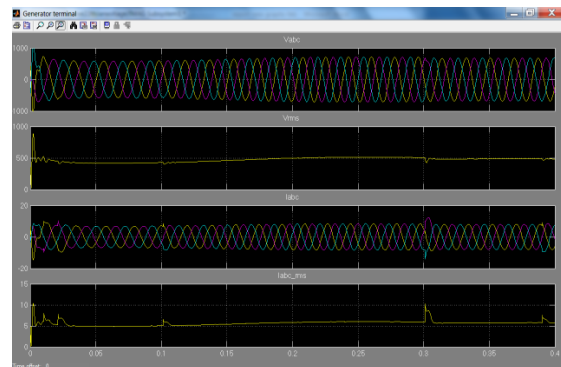

Figure 6: IG terminal voltage and current

The model presents a near constant voltage and current values at the generator and at the load terminal as shown in figures 7&8 below.



Figure 7: load voltage and current parameters

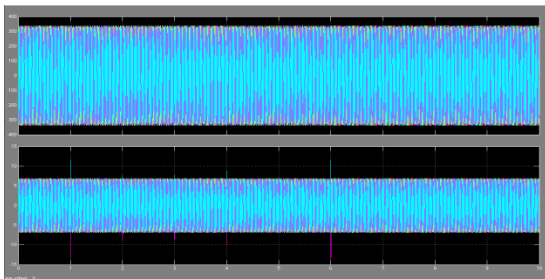

Figure 8: Load terminal voltage and current waveforms characteristics

This model gives merits of effective automation for load management and simplicity of the circuitry that comprises of logic gate sensors. This model is applicable for three phase, single phase, dc or ac ballast loads. It however has a limitation of a need to custom design for each site to determine the load and ballast circuits beforehand.

The voltage and current waveforms portray pure sine waves without distortion. This is very crucial for loads to properly function especially for frequency sensitive type of loads for example the fans.

The response to load changes last a few microseconds before the system regains stability. This time lag of either a voltage dip/surges or current increase on average lasted about 0.03miliseoconds (figure 6) at load switching points. 250V was the highest voltage drop realised.The frequency of the systems was below 60 Hz.

The cost of the semiconductor devices ranges from 3 to 10 USD (RS Components Ltd.) per device which is affordable. The cost of having an AC dump load system is much more compared to one with a DC one and proper equipment selection is required.

#### 4.2 Results for model 2

The figures also shows the scope waveforms for the model performances

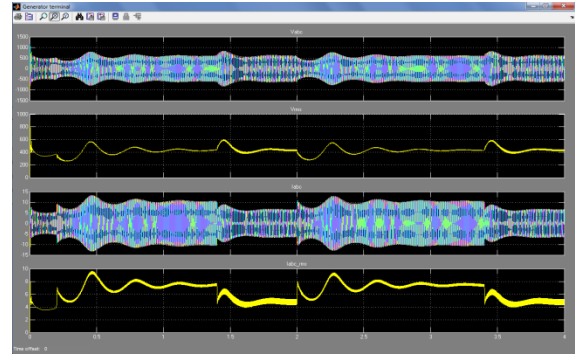

Figure 9:IG voltage and current waveforms

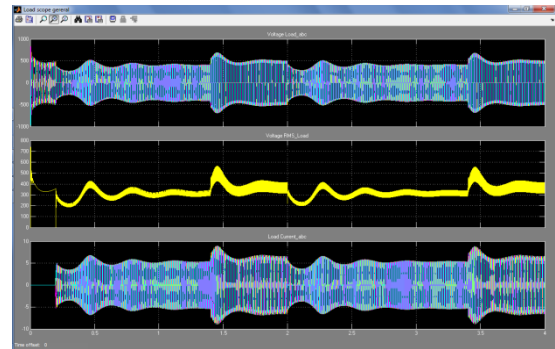

Figure 10: Load terminal volatge and current wave forms

Voltage waveforms: the waveforms are generally not as smooth as the in the previous discussion. There are rugged sinusoidal waveforms with distortions especially when the dump load on connected at load switching points (figure 9&10). At longer simulation periods, the appearance then becomes nearly constant.

Response to load variations: this is reflected with voltage and current surges. The system stability is regained after abut 2miliseconds and this is longer than in the previous control technique.

Frequency: Results show a minimum variation in frequency and most pronounced at load switching points.

Cost: the cost of the PID and the reference block components could go for more than 200USD. The rest of the model components are as applied to the previous model. This design is more expensive but more flexible with site installation.

Technical design: this technique is not as simple as the previous because it needs more technical capacity and finer tuning knowledge for proper functioning. On the local market the previous one could be easier to design by a technician.

General operational: the model was successful designed to control and regulate the voltage at the IG system with a typical load profile design in the simplest way possible.

#### 4.3 Case study for a PQA results

Data collection and site measurements for the performance this Pico hydropower site were taken using a PQA824, which recorded the power details and saved the screen snapshots to assess the performance of the plant. The graphs below give the power characteristics of the site.

### Scheme with a constant load connected

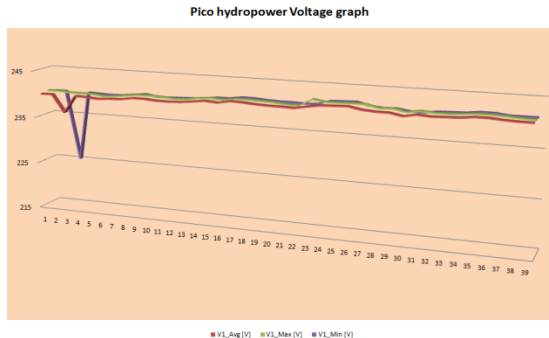

Figure 11: Voltage waveform at a constant load

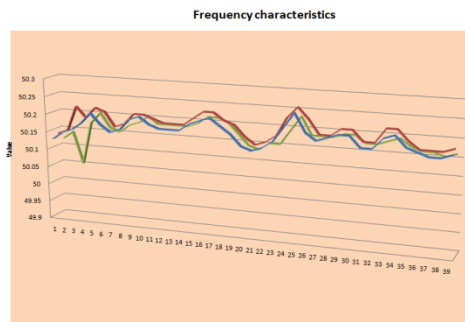

Figure 12: Frequency variation at a constant load

### Scheme with load variation

The scheme response to load changes was achieved by varying the load connected at a time. The data was recorded for longer periods and sampling done every after 5 seconds.

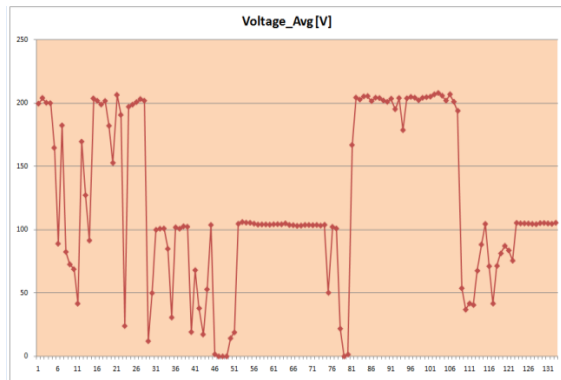

Figure 12: Voltage characteristics

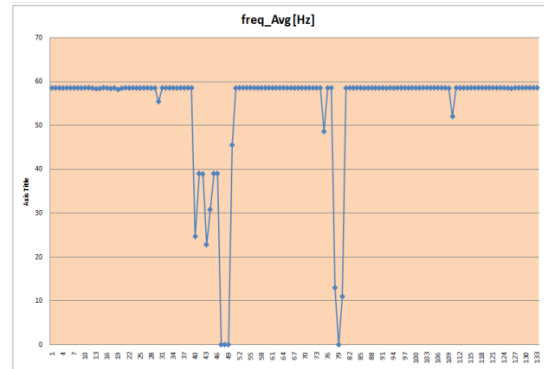

Figure 13: Frequency characteristics

Superimposing the frequency onto the voltage curve ensuring a near constant load at the induction generator resulted into the following waveform characteristics

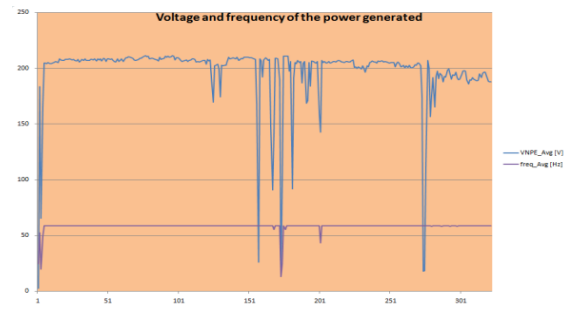

Figure 14: Site characteristics

The data collected from RMS site indicates the following:

- The system maintains a constant frequency when properly operated which is very crucial with power quality. Variations are later on realized with connection of the PQA meter for longer periods but these are within range. The highest recorded value was 59 Hz
- The average voltage variation is stable even though the max value indicated shows a shoot up in the value. The nature of the voltage sine wave is seen to be fairly smooth but with load increases, the voltage drops for over a few seconds to half the voltage (figure 12). This takes on a long time (more than a minute) before stability is regained.
- The cost implication of having a manual system is higher in a long run given that it needs fulltime technical and immediate attention for every load switching. This is made easier and more efficient with an automatic system.

## 5. CONCLUSION

This paper shows the two models designed to simulate a Pico hydropower scheme using two different automatic load control techniques. The

performance of each is clearly shown and the comparison to the manual system for the case study in western Uganda.

Various publications have presented diverse techniques which perform better than these two but this research sought alternatives that could be easier for local technical capacity to develop within Uganda such that hydropower schemes such as RMS could make use of them at an affordable cost.

Further research is recommended to be done for practical hands on for the models and improvements to ensure that flexibility and better performance is incorporated.

The paper emphasizes what other researchers have mentioned that every Pico hydropower scheme using of induction generators needs an electronic load controller as compared to a manual one if at all the quality of power generated is to be to the required standards. Manual operations need technical responsible and careful operators

## 6. APPENDIX

### 1. Power house and equipment

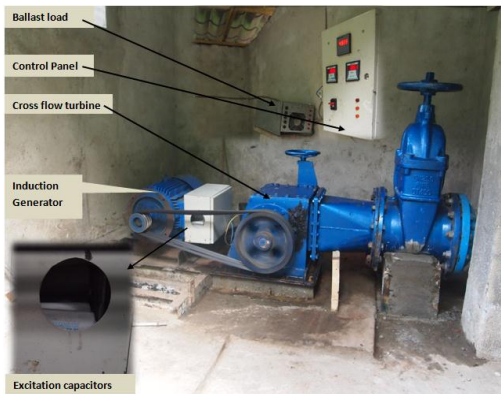

## 7. REFERENCES

- [1] K. Subramanian\*, K. K. Ray\*, K. Hari Prasad, Nand Gopal.E, Nimisha Gupta, Nirupama.V, Pragyajha and Meenakshi Sinha (2010). State Of The Art of Electronic Load Controller of Self-Excited Asynchronous Generator Used In Mini / Micro Hydro Power Generation \*Power Electronics Division, School of Electrical Engineering VIT University Vellore, Tamil Nadu, India, 632 014 IEmail id: [ksubramanian@vit.ac.in](mailto:ksubramanian@vit.ac.in)
- [2] Smith, Nigel. *Motors as Generators for Micro hydro power*. India : Practical Action Publishing, 2008
- [3] C. F. Wanger, "Self-Excitation Of Induction Motors," AIEE Trans., vol. 58, pp. 47–51, 1939.
- [4] S. S. Murthy, O. P. Malik, and A. K. Tandon, "Analysis of self excited induction generator," Proc. Inst. Elect.Eng. C, vol. 129, no. 6, pp. 260–265, Nov. 1982
- [5] G. Raina and O. P. Malik, "Wind Energy Conversion Using A Self-Excited Induction Generator," IEEE Trans.Power App. Syst., vol. PAS -102, no. 12, pp. 3933–3936, Dec. 1983.
- [6] J.K.Chatterjee, B.M. Doshi and K.K.Ray, " A New method for thyristor phase controlled Var compensator", IEEE/PES winter meeting 89.WM 133 – OPWRS, New York, 1989.
- [7] K. K. Ray, " Performance Evaluation of A Novel Var Controller And Its Application In Brushless Stand Alone Power Generation," Ph.D. Thesis, department of Electrical Engineering, IIT Delhi, India, 1990.
- [8] Bhim, S., Murthy, S.S., (2006). Analysis and design of the Electronic Load Controller for Self Excited Induction Generator, IEEE Transactions on Energy Conversion, (Vol. 21), no. 1, March.
- [9] R. Bonert and G. Hoops, "Stand alone induction generator with terminal impedance controller and no turbine controls," in *Proc. IEEE Power Engineering Soc. Summer Meeting*, 1989, pp. 28–31.
- [10] N. Elsonbaty, P. G. Holmes, M. Salama, N. P. A. Smith, and A. A. Williams, "VSCF induction generation in stand-alone micro-hydro generating systems," in *Proc. Renewable Energy Conf.*, 1993, pp. 89–94.
- [11] S. Rajakaruna and R. Bonert, "A technique for the steady-state analysis of a self-excited induction generator with variable speed," *IEEE Trans.Energy Convers.*, vol. 8, no. 4, pp. 757–761, Dec. 1993.
- [12] N. P. A. Smith, "Induction generators for stand-alone micro-hydro systems," in *Proc. IEEE Int. Conf. Power Electronics Drive Energy Systems for Industrial Growth*, New Delhi, India, 1996, pp. 669–673.
- [13] A.-R. A. M. Makky and N. A. El-Latif, "Integral-cycle control with a d.c. chopper controller for single-phase induction motor," *Elect. Power Syst. Res.*, vol. 40, pp. 91–98, 1997.
- [14] F. A. Farret, C. A. Portolann, and R. Q. Machado, "Electronic control by the load for asynchronous turbogenerators, driven by multiple sources of energy," in *Proc. IEEE Conf. Devices, Circuits, Systems*, 1998, pp. 332–337.
- [15] D. Henderson, "An advanced electronic load governor for control of micro hydroelectric generation," *IEEE Trans. Energy Convers.*, vol. 13, no. 3, pp. 300–304, Sep. 1998.
- [16] R. Bonert and S. Rajakaruna, "Self-excited induction generator with excellent voltage and frequency control," *Proc. Inst. Elect. Eng., Gen.*

- Transm. Distrib.*, vol. 145, no. 1, pp. 33–39, Jan. 1998.
- [17] S. S. Murthy, R. Jose, and B. Singh, “Experience in the development of microhydel grid independent power generation scheme using induction generators for Indian conditions,” in *Proc. IEEE Int. Conf. Global Connectivity Energy, Computer, Communication, Control*, vol. 2, 1998, pp. 461–465.
- [18] Energypedia; Uganda Energy Situation [https://energypedia.info/wiki/Uganda\\_Energy\\_Situation](https://energypedia.info/wiki/Uganda_Energy_Situation) (Accessed on the 20<sup>th</sup> May 2014)
- [19] Electricity Regulatory Agency, Issue 8 2013
- [20] Maher, P. (2002). *Micro Hydro Centre. Community Pico Hydro in Sub-Saharan Africa/ Case Study Two/ Thima, Kirinyaga District, Kenya*, the Nottingham Trent University
- [21] Akshay Urja Renewable Energy. ( February 2012). *Pioc hydro in Karnataka. Volume 5, Issue 3.*
- [22] People, Energy & Environment Development Association [PEEDA]. (2009).
- [23] *Low Head Pico-Hydro Promotion Project* [Brochure]. Kathmandu, Nepal: Author
- [24] Ministry of Energy and Mineral Development. *The Renewable Energy Policy for Uganda*. Kampala : New Vision, 2007

**Co-author:** Assoc. Prof Okou Richard is a lecture at Makerere University, Department of Electrical and computer engineering. PhD in Electrical Engineering, (University of Cape Town), Master of Science in Sustainable Energy Engineering (KTH Stockholm), Bachelor of Science in Electrical engineering (Makerere University). He is a member, Institute of Electrical and Electronics Engineering (IEEE), USA and the Institute of Engineers and Technologists (IET), UK

**Co-author:** Mary Suzan Abbo holds a master’s of Science in Utilities and Waste Sustainable Processing from Karlsruhe University, Germany and a Bachelor of Science in Civil Engineering from Makerere University. Currently a PhD in renewable energy at Makerere University

**Presenter:** The paper is presented by Teddy Nalubega

#### **Principal Author:**



Teddy Nalubega holds a BSC in Electrical Engineering from Makerere University and at present completing an MSc in Renewable Energy at the same University.

#### **Co-author::**



Prof. Izael Da Silva holds a PhD in Power Systems Engineering from University of Sao Paulo, Brazil and is the director of SERC – Strathmore Energy Research Centre in Nairobi. He is also one of the partners for the implementation of the Kenya Climate Innovation Centre managed by the World Bank and supported by DANIDA and DFID.

+254(0)733900400 [idasilva@strathmore.edu](mailto:idasilva@strathmore.edu)