



---

**Electronic Theses and Dissertations**

---

2020

# Block Chain Technology to enhance food traceability and safety: case study of Agriculture Industry in Kenya.

Lesiit, Lenjula Letitoiya  
*Faculty of Information Technology*  
*Strathmore University*

## **Recommended Citation**

Lesiit, L. L. (2020). *Block Chain Technology to enhance food traceability and safety: Case study of Agriculture Industry in Kenya*. [Thesis, Strathmore University]. <http://hdl.handle.net/11071/12090>

Follow this and additional works at: <http://hdl.handle.net/11071/12090>

**BLOCK CHAIN TECHNOLOGY TO ENHANCE FOOD TRACEABILITY AND  
SAFETY.**

**CASE STUDY OF AGRICULTURE INDUSTRY IN KENYA**



A Thesis Proposal Submitted to the Faculty of Information in partial fulfillment of the requirements for the award of Master of Science in Information Technology of Strathmore University

**STRATHMORE UNIVERSITY**

April 2020

## Declaration

This research proposal is my original work and has not been presented for a degree in any other university. No part of this proposal may be reproduced without the prior permission of the author and/ or Strathmore University. All other sources of information cited herein have been duly acknowledged.

Signature .....  ..... Date .....13/07/2020.....

Name: Lenjula Letitoiya Lesiit

Registration Number: 094757

### SUPERVISOR'S DECLARATION

This thesis has been submitted for review with my approval as a university supervisor.

Signature.....  ..... Date.....13/07/2020.....

Prof. Ismail Ateya Lukandu, D.Sc.

Faculty of Information Technology,  
Strathmore University.

# Table of Contents

Declaration .....	ii
Table of Contents .....	iii
Abstract .....	x
Acknowledgements .....	xi
Abbreviations/ Acronyms .....	xii
Definition of Terms .....	xiii
List of Figures .....	xiv
List of Tables .....	xvii
Chapter 1 : Introduction .....	1
1.1. Background .....	1
1.2. Problem Statement .....	2
1.3. Aim .....	5
1.4. Specific Objectives .....	5
1.5. Research Questions .....	5
1.6. Justification .....	6
1.7. Scope and Limitation .....	6
Chapter 2 : Literature Review .....	8
2.1. Introduction .....	8
2.2. Theoretical Framework .....	8
2.2.1. Various Actors and Stakeholders in Food Supply Chain in Kenya .....	8
2.2.2. Current Techniques, Models and Technologies Used in Blockchain Technology .....	15
2.2.2.1. Transaction definition .....	18

2.2.2.2. Transaction authentication .....	19
2.2.2.3. Block Validation .....	19
2.2.2.4. Block chaining.....	20
2.3. Empirical Review.....	26
2.4 Conceptual Framework/Proposed Architecture .....	29
Chapter 3 : Research Methodology.....	30
3.1 Introduction .....	30
3.2 Agile Software Development Methodology .....	30
3.3 Research Design.....	31
3.3.1 System Architecture .....	32
3.3.2 System Analysis.....	33
3.3.3 System Design.....	34
3.3.4 System Implementation.....	34
3.3.5 System Testing.....	34
3.4 Target Population .....	35
3.5 Sample Techniques and Sample Size.....	36
3.6 Data Collection Procedure .....	36
3.7 Data Analysis Procedure.....	37
3.8 Research Quality Aspects.....	37
3.8.1 Validity.....	37
3.8.2 Reliability.....	37
Chapter 4 : System Design and Architecture.....	39
4.1. Introduction .....	39
4.2. Data Analysis .....	39
4.2.1 Degree of Response.....	39

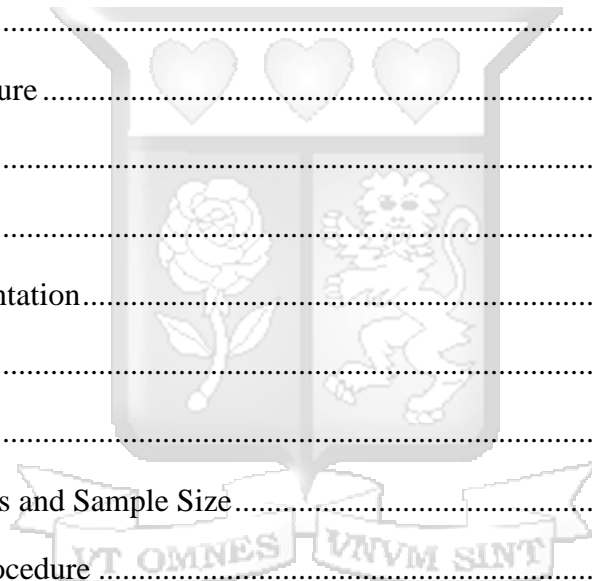

4.2.2 Farmers.....	40
4.2.2.1 Respondents details .....	40
4.2.2.2 Whether Farmers Use Mobile Service Delivery to Market and Check Pricing Information .....	40
4.2.2.3 Whether Farmers Use Tagging of the Produce (RFID/Bar Code) For Tracking Information .....	41
4.2.2.3 Whether Farmers Have a System to Capture the Source of Manure and Water Usage .....	41
4.2.2.4 Whether Farmers Have a System to Capture the Details of the Wholesaler Who Collects Their Produce .....	42
4.2.2.5. Whether Farmers have Strategies to Control Foodborne Pathogens in their Farm ..	43
4.2.2.6. What Approaches the Farmer Uses to Ensure their Produce are Traceable and Safe .....	43
4.2.2.7. Considering the Approaches Selected Above Only, Rate the Same on the Effectiveness in Enhancing Food Traceability and Safety .....	44
4.2.2.8. Rate the Challenges You Have Experienced with Produce Traceability and Produce Safety .....	45
4.2.2.9. Would the Farmers Like to have a System that will Enhance Food Traceability and Food Safety of their Produce .....	46
4.2.2.10. Medium to Access the System Via.....	46
4.2.2.11. Would You Sell To Customers Directly or to Distributors .....	47
4.2.2.12. Authentication Preference by the Farmers .....	48
4.2.2.12. Whether the Farmer would like to Buy Farm Produce Directly from Producers or Wholesaler .....	49
4.2.3. Food Processing Companies .....	49
4.2.3.1. Whether the Company has Ever Registered a Food Borne Crisis .....	50
4.2.3.2. At What Stage the Company did the Food Get Contaminated.....	51

4.2.3.3. Company’s Action after Finding Out of the Food Borne Issue.....	51
4.2.3.4. Approaches Employed by the Companies to Enhance Food Traceability and Safety .....	52
4.2.3.5. Considering the Approaches Selected Above Only, Rate the Same on the Effectiveness in Enhancing Food Traceability and Safety .....	52
4.2.3.6. Rate the Challenges You Have Experienced with Produce Traceability and Produce Safety Considering the above Approaches .....	53
4.2.4. Food Consumers/Customers .....	54
4.2.4.1. The Age Range of the Respondents .....	54
4.2.4.2. The Gender of the Respondents.....	55
4.2.4.2. The Education Level of the Respondents .....	56
4.2.4.2. Whether the Customer have ever been Victim of a Food Borne Disease Case.....	56
4.2.4.2. Whether the Customer found out at What Stage the Food Contamination Took Place .....	57
4.2.4.3. Whether Farmers Use Mobile Service Delivery to Market and Check Pricing Information .....	58
4.2.4.4. Whether Farmers Use Tagging of the Produce (RFID/Bar Code) For Tracking Information .....	59
4.2.4.5. Whether Farmers Have a System to Capture the Source of Manure and Water Usage .....	60
4.2.4.6. Whether Farmers Have a System to Capture the Details of the Wholesaler Who Collects Their Produce .....	60
4.2.4.7. Whether Farmers have Strategies to Control Foodborne Pathogens their Your Farm .....	61
4.2.4.8. What Approaches the Farmer Uses to ensure their Produce are Traceable and Safe	62
4.2.4.9. Considering the Approaches Selected Above Only, Rate the Same on the Effectiveness in Enhancing Food Traceability and Safety .....	62

4.2.4.10. Rate the Challenges the Farmers will Experience with Produce Traceability and Produce Safety Considering the Above.....	62
4.2.4.11. Medium to Access the System Via.....	64
4.2.4.12. Would You Buy Directly from the Farmers or Would You Buy from Distributors .....	64
4.2.4.13. Authentication Preference by the Customers .....	65
4.2.5 Summary of Data Analysis .....	65
4.2.6 Data Analysis Discussions .....	67
4.3. Requirements Analysis.....	67
4.3.1. Functional Requirements.....	67
4.3.2. Non-functional Requirements .....	69
4.4. System Design.....	69
4.4.1 System Architecture .....	70
4.4.2 Context Diagram .....	72
4.4.3 Use Case Diagram.....	73
4.4.4 Sequence Diagram.....	77
4.4.5 Data Flow Diagram .....	77
4.4.6 Entity Relationship Diagram.....	78
4.4.7 Database .....	79
Chapter 5 : System Implementation and Testing.....	80
5.1 Introduction .....	80
5.2 System Implementation.....	80
5.2.1 Application Hardware Requirements .....	80
5.2.1.1 Server Specifications .....	80
5.2.1.2 Mobile Application.....	80
5.2.2 Application Software Requirements .....	80

5.2.2.1 Framework.....	80
5.2.2.2 Language .....	81
5.2.2.5 Ionic.....	81
5.2.2.6 MySQL.....	81
5.2.3 System Users and Graphical User Interface.....	81
5.2.3.1 Landing Page.....	81
5.2.3.2 Sign-Up page.....	83
5.2.3.4 User Roles.....	85
5.2.4 User Roles and Graphical User Interface.....	86
5.2.4.1 Farmer User Role.....	86
5.2.4.2 Government User Role.....	87
5.2.4.3 Customer User Role.....	88
5.2.4.4 Processing Company User Role.....	90
5.2.4.5 Super Administrator User Role.....	91
5.3 System Testing.....	92
5.3.1 Functional Testing.....	92
5.3.2 Usability Testing.....	94
5.3.3 Regression Testing.....	94
5.3.3.1 Customer Browsing the Catalogue.....	94
5.3.3.2 Customer Reading the Product Details.....	95
5.3.3.3 Customer Scanning Bar Code.....	96
5.3.5 Compatibility Testing.....	97
Chapter 6: Discussion.....	99
6.1 Introduction.....	99
6.2 Findings and Achievements.....	99

6.3	Review of Research Objectives in Relation to the Mobile Application .....	99
6.4	Advantages of the Application in Contrast with the Current System .....	100
6.5	Limitations of the Application .....	101
6.6	Application, Efficiency and Ease of Use .....	101
Chapter 7: Conclusions, Recommendations and Future Work.....		103
7.1	Introduction .....	103
7.2	Conclusions .....	103
7.3	Recommendations .....	104
7.4	Future Work .....	105
REFERENCES .....		107
APPENDICES .....		117
Appendix A: Time Schedule.....		117
Appendix B: Farmers Questionnaire.....		118
Appendix C: Food Processing Companies Questionnaire .....		123
Appendix D: Customers of Farm Produce Questionnaire.....		127
Appendix E: NACOSTI Research Authorization Letter.....		133
Appendix F: NACOSTI Research Permit .....		134

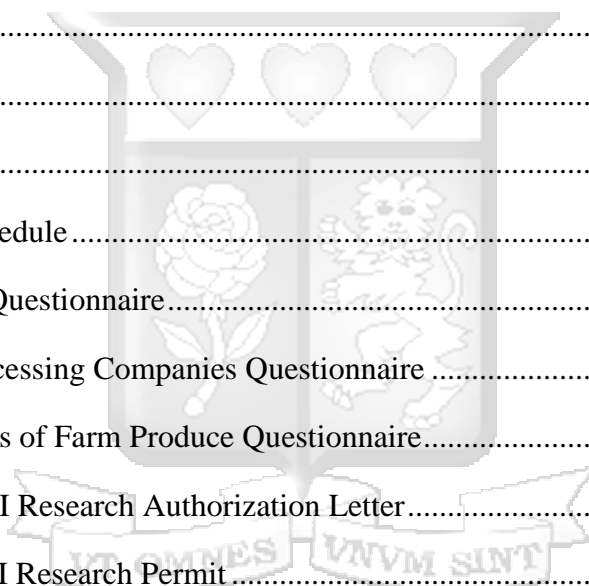

## Abstract

Food safety has been one of the growing concerns and challenges in African countries. We had reports of sub standards food stuff, including chemically made eggs being sold to un-suspecting citizens. This is a global challenge, however, it is worth mentioning that it has been a serious issue in Africa due to rampant corruption where the oversight institution are easily compromised by unscrupulous business entities mainly because of lack of tracking system that enable the public know who made decisions or certain approvals. In South Africa, Listeria Outbreak caused 203 fatalities by the time the outbreak was declared over in September 2018. Closer home, Kenya has seen a fair share of food scandal starting with the infamous Aflatoxin-contaminated maize in Kenya resulted in 317 cases of hepatic failure and 125 deaths. There is lack of a system that would ensure companies and individuals involved in production of agricultural produce keep highest level of ethics; through a transparent supply chain management system that not only give the policy makers and oversight organization openness but also neutrality, reliability and thus security of the produce from the farm to table. This projects main objective is to develop a system that will guarantee food quality and safety from supply chain perspective by applying blockchain technology in agricultural supply-chain management, from farm to table. Since its conception in 2008, blockchain has developed over the last decade into one of today's biggest technologies with a massive potential to impact virtually every industry from financial to manufacturing to educational institutions. Blockchain provided the answer to digital trust because it records important information in a public space and doesn't allow anyone to remove it; it's transparent, time-stamped and decentralized. The system developed enhances food safety and integrity through higher traceability thus helping everybody stakeholder in the supply chain quickly trace outbreaks back to specific sources, which could mitigate food fraud or food crises. The stakeholder are not only able to get quality and safer products but also forces the dishonest business entities out of business therefore making the market safe. The system offers many other benefits tandem to the blockchain attributes such as, providing a secure way to perform transactions among untrusted parties; decentralizing ledger that helps in connecting inputs, suppliers, producers and buyers.

## **Acknowledgements**

I am highly grateful to our Lord and Saviour Jesus Christ for all His wisdom, knowledge and understanding.

I truly appreciate my supervisor; Prof.. Ismail Ateya Lukandu for all the support he has given me in guiding me through this thesis writing. Thank you for your invaluable advice, guidance and patience throughout my proposal writing.

I express my gratitude to my parents for providing me with unfailing support and continuous encouragement throughout my years of study and through the process of researching and writing this thesis. This accomplishment would not have been possible without them



## Abbreviations/ Acronyms

<b>CSS</b>	-	Cascading Style Sheet
<b>ERD</b>	-	Entity Relationship Diagram
<b>IDE</b>	-	An integrated development environment.
<b>KEBS</b>	-	Kenya Bureau of Standards
<b>SDK</b>	-	A software development kit
<b>WHO</b>	-	World Health Organization
<b>ICC</b>	-	International Criminal Court
<b>IFOAM</b>	-	International Federation of Organic Agricultural Movements
<b>UML</b>	-	Unified Modelling Language
<b>FAO</b>	-	Food and Agriculture Organization
<b>NGO</b>	-	Non-Governmental Organization
<b>RFID</b>	-	Radio-frequency identification
<b>GMO</b>	-	Genetically Modified Organism

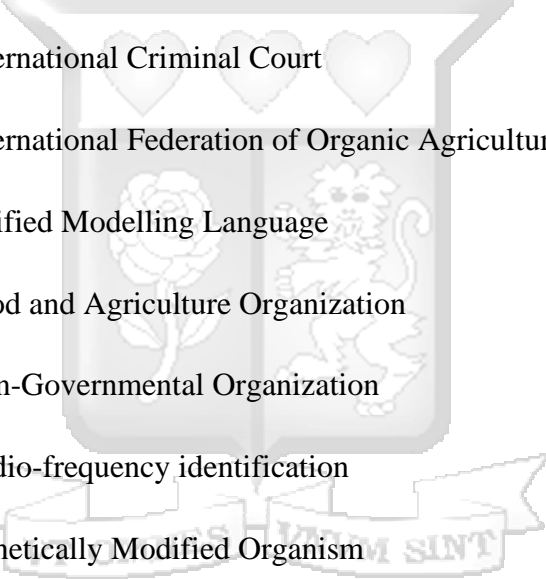

## Definition of Terms

**Algorithm** A process or set of rules to be followed in calculations or other problem-solving operations, especially by a computer (Dictionary.com, n.d).

**Arrays** An array is a data structure that contains a group of elements. (Christensson, 2007).

**JavaScript** JavaScript is the only scripting language able to run on nearly all browsers (Gamage & Dong, 2006).

**JSON** JavaScript Object Notation (Goyal, Singh, & Ramkumar, 2017; Guo, Xia, & Xiang, 2017)

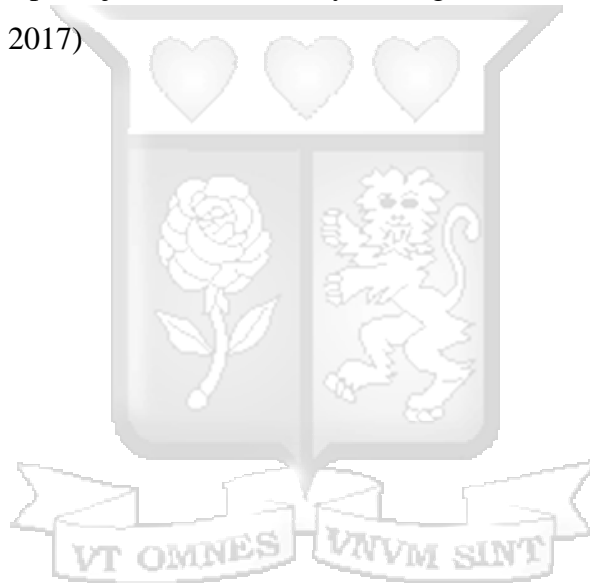

## List of Figures

Figure 2.1 : Interrelation of Stakeholder in the Food Supply Chain.....	11
Figure 2.2 : Different Network Structures .....	17
Figure 2.3 : Signing and Verifying of Transaction.....	18
Figure 2.4 : Blocks Linked to Chain.....	19
Figure 2.5 : Structure of blockchain .....	20
Figure 2.6 : Basic Logical structure of the Whole Research .....	26
Figure 2.7 : Conceptual Framework of an Agri-food Supply Chain Traceability System Based on RFID & Blockchain Technology .....	27
Figure 2.8 : The Proposed Framework of a Blockchain Supported Traceability System.....	28
Figure 2.9 : Conceptual Framework of a Blockchain-based System with Smart Contracts.....	29
Figure 3.1 : Agile Methodology.....	31
Figure 3.2 : Blockchain Process.....	33
Figure 3.3 : Object-oriented Analysis and Design (OOAD) Artifacts.....	33
Figure 4.1 : The Average Rating for the Level of Embracing of use of Mobile Service Delivery to Market and Check Pricing Information .....	40
Figure 4.2 : The Average Rating for Level of Use of Tagging of the Produce (RFID/bar code) by Farmers for Tracking Information .....	41
Figure 4.3 : The Average Rating for Level of Use of System to Capture the Source of Manure and Water Usage.....	42
Figure 4.4 : The Average Rating for Level of Use of System to Capture the Details of the Wholesaler Who Collects Farmers Produce .....	42
Figure 4.5 : Average Rating on the whether the Farmers have Strategies to Control Foodborne Pathogens .....	43
Figure 4.6 :Approaches the Farmers Use to Ensure their Produce are Traceable and Safe .....	44
Figure 4.7 : User Preference on Access of the System.....	47
Figure 4.8 : Sale Preference for the Farmers .....	48
Figure 4.9 : Authentication Preference by the Farmers .....	48
Figure 4.10 : Procurement of Farm Inputs Preference by the Farmers.....	49
Figure 4.11 : Position of the Respondents in the Respective Companies.....	50
Figure 4.12 : Education Level of the Respondents .....	50

Figure 4.13 : Percentage of Companies that have Registered Food borne Cases.....	51
Figure 4.14 :Stage of Contamination of the Company Products .....	51
Figure 4.15 : Popularity of the Approaches by the Companies .....	52
Figure 4.16 : .....	55
Figure 4.17 : The Gender of the Respondents .....	55
Figure 4.18 : Education Level of The Reponsesdents.....	56
Figure 4.19 : Percentage of the Respondents who have Experienced Case of Food Borne Disease .....	57
Figure 4.20 : The Stage at which the Respondents Believe the Contamination took Place .....	58
Figure 4.21 : The Average Rating for the Level of Embracing of use of Mobile Service Delivery to Market and Check Pricing Information .....	59
Figure 4.22 : The Average Rating for Level of Use of Tagging of the Produce (RFID/bar code) by Farmers for Tracking Information .....	59
Figure 4.23 : The Average Rating for Level of Use of System to Capture the Source of Manure and Water Usage .....	60
Figure 4.24 : The Average Rating for Level of Use of System to Capture the Details of the Wholesaler Who Collects Farmers Produce .....	61
Figure 4.25 : Average Rating on the whether the Farmers have Strategies to Control Foodborne Pathogens .....	61
Figure 4.26 : User Preference on Access of the System.....	64
Figure 4.27 : Commerce Preference of Customers.....	65
Figure 4.28 : Authentication Preference by the Customers .....	65
Figure 4.29 : System Architecture of Block Chain System to Enhance Food Traceability and Safety: .....	71
Figure 4.30 : Context Diagram of the Block Chain System to Enhance Food Traceability and Safety: .....	72
Figure 4.31 : Use Case Diagram.....	76
Figure 4.32 : Sequence Diagram of the System.....	77
Figure 4.33 : Data Flow Diagram of the System .....	78
Figure 4.34 : Entity Relationship Diagram of the System .....	79
Figure 5.1: Web Interface of the Landing Page for Food Traceability and Safety System.....	82

Figure 5.2 : Mobile Interface of the Landing Page for Food Traceability and Safety System.....	83
Figure 5.3 : Web Sign-up page .....	84
Figure 5.4 : Mobile Sign-up page .....	85
Figure 5.5 : Verification Page of the System by the Government User Role.....	86
Figure 5.6 : Parent Profile Dashboard - Web Impression.....	87
Figure 5.7 : Government User Role - Web Impression .....	88
Figure 5.8 : Customer/Consumer Role Dashboard.....	89
Figure 5.9 : Processing Company Role Dashboard .....	91
Figure 5.10 : Super Administrator User Role - Web Impression .....	92
Figure 5.11 : Customers' Usability Feedback.....	94
Figure 5.12 : Catalogue View for Customer.....	95
Figure 5.13 : Product Information View for the Customer.....	96
Figure 5.14 : Bar/QR Code Scanner .....	97

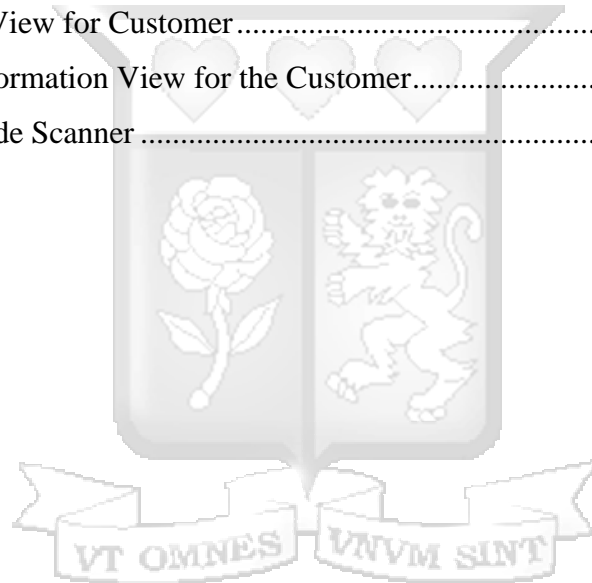

## List of Tables

Table 2.1 : Agri-food Chain Stakeholders in Various Sectors.....	9
Table 2.2 : Overview of the main Characteristics of Food Supply Chain Networks and their impact on Logistics and Information and Communication Technology .....	14
Table 2.3 : Comparison between Bitcoin, Legal Currency and Traditional Online Payments.....	16
Table 2.4 : Essential Parts of Blockchain Technology .....	22
Table 3.1 : Types of Tests Used in the Project .....	35
Table 4.1 : Table Showing the Average Rating of the Effectiveness of Approaches Selected by Farmers .....	45
Table 4.2 : The Average Rating for Level of Challenges Farmers have Experienced with Produce Traceability and Produce Safety .....	45
Table 4.3 : The Average Rating the Approaches on the Effectiveness to Enhance Food Traceability and Safety .....	53
Table 4.4 : The Average Rating for Level of Challenges Companies have Experienced with Product Traceability and Produce Safety.....	53
Table 4.5 : Showing the Average Rating of the Effectiveness of Approaches Selected by Farmers .....	62
Table 4.6 : The Average Rating for Level of Challenges Farmers have Experienced with Produce Traceability and Produce Safety .....	63
Table 4.7 : Use Case Main Success Story.....	74
Table 5.1 : Functional Testing Variables and Results .....	92
Table 5.8 : Web Compatibility Test Results.....	97
Table 5.9 : Mobile Operating System Compatibility Test Results .....	98

# Chapter 1 : Introduction

## 1.1. Background

Food quality and safety has not only been an Africa concern but a global one. The World Health Organization (WHO), acknowledges this by virtue changing food habits, popularization of mass catering establishment and notably, globalization of the world food supply chain. As our food supply becomes increasingly globalized, the need to strengthen food safety systems in and between all countries is becoming more and more evident (WHO, 2017).

Food scandal cases have been growing Africa, corruption being the main catalyst that is propelling the challenge. In South Africa, Listeria Outbreak caused 203 fatalities by the time the outbreak was declared over in September 2018 (Child, 2018). In March of 2016, there were reports of low quality import of chicken from United States of America to South Africa after two countries agreed on the terms for South Africa to be included in the African Growth and Opportunity Act (Miya, 2019). The outrage that followed was not only around the quality of the chickens, but also the financial impact on the local poultry industry. Closer home, Kenya has seen a fair share of food scandal starting with the infamous Aflatoxin-contaminated maize in Kenya resulted in 317 cases of hepatic failure and 125 deaths (Probst, Bandyopadhyay, Price & Cotty, 2011).

In 2007, when Kenya was experience gran shortage, a record time importation of maize from Mexico was the topic of discussion a it emerged that this was consignment of surplus of an old stock that was imported by South Africa the previous year when they were experiencing food shortages The matter was complicated by Mexican embassy coming out to clarify that it did not confirm the transaction of the importation of the maize from Mexico (Marete, Andae & Bii, 2017). Fast forward to 2018, Kenya was grappling with yet another scandal with fears of Mercury in the sugar that was circulating in the market (Lime, 2018; Nyamori, 2018).

The above cases are just but a handful of cases in the African states, involving food scandals that not only affect the food safety and quality but affect the economic status of the farmers as well. As rightfully noted by the World Health Organization, and from the above text, it's clear that it

would be myopic to look at food scandals from a regional perspective, not to mention country level, as the globe edges day by day towards a global village economical. A case of Corona virus that originated in China due to poor handling of animal is another example of how the world is mere village. The virus has ended up affecting countries far away from China more than it did affect China degenerating to a global pandemic ("Coronavirus Disease (COVID-19) - events as they happen", 2020).

The project will endeavour to develop a blockchain system that will inject transparency and accountability in the food production and supply chain. Block chain technology came about to solve the challenge of currency transactions. Currency transactions between persons or companies are usually centralized and controlled by a third party organization such as a bank. Making a digital payment or currency transfer requires a bank or credit card provider as a middleman to complete the transaction. In addition, a transaction causes a fee from a bank or a credit card company. The transaction system is typically centralized, and all data and information are controlled and managed by a third party organization, rather than the two principal entities involved in the transaction. The goal of Blockchain technology is to create a decentralized environment where no third party is in control of the transactions and data.

Blockchain is a solution with distributed database which maintains a growing list of data records that are confirmed by the nodes participating in it, in our case the nodes will be the stakeholders in the production and supply chain of the food products. Blockchain is a decentralized solution which does not require any third party organization in the middle. The information about every transaction ever completed in Blockchain is shared and available to all nodes. This attribute makes the system more transparent than centralized transactions involving a third party. In addition, the nodes in Blockchain are all anonymous, which makes it more secure for other nodes to confirm the transactions (Yli-Huumo, Ko, Choi, Park & Smolander, 2016).

## **1.2. Problem Statement**

The good percentage of people from all over the world will experience a foodborne disease at some point in their lives. This outlines the significance of making sure the food we eat is safe and not contaminated with potentially harmful bacteria, parasites, viruses, toxins and chemicals. World Health Organization lists the below ten facts about food safety (WHO, 2016):

- i. Fact 1: More than 200 diseases are spread through food**
  - a. 1 in 10 people fall ill every year from eating contaminated food, and 420 000 people die each year as a result. Children under 5 years of age are at particularly high risk, with some 125 000 young children dying from foodborne diseases every year.
- ii. Fact 2: Contaminated food can cause long-term health problems**
  - a. The most common symptoms of foodborne disease are stomach pains, vomiting and diarrhoea. Food contaminated with heavy metals or with naturally occurring toxins can also cause long-term health problems including cancer and neurological disorders.
- iii. Fact 3: Foodborne diseases affect vulnerable people harder than other groups**
  - a. Infections caused by contaminated food have a much higher impact on populations with poor or fragile health status and can easily lead to serious illness and death. For infants, pregnant women, the sick and the elderly, the consequences of foodborne disease are usually more severe and may be fatal.
- iv. Fact 4: There are many opportunities for food contamination to take place**
  - a. Today's food supply is complex and involves a range of different stages including on-farm production, slaughtering or harvesting, processing, storage, transport and distribution before the food reaches the consumers.
- v. Fact 5: Globalization makes food safety more complex and essential**
  - a. Globalization of food production and trade is making the food chain longer and complicates foodborne disease outbreak investigation and product recall in case of emergency.
- vi. Fact 6: Food safety is multisectoral and multidisciplinary**
  - a. To improve food safety, a multitude of different professionals are working together, making use of the best available science and technologies. Different governmental departments and agencies, encompassing public health, agriculture, education and trade, need to collaborate and communicate with each other and engage with the civil society including consumer groups.
- vii. Fact 7: Food contamination also affects the economy and society as a whole**

- a. Food contamination has far reaching effects beyond direct public health consequences – it undermines food exports, tourism, livelihoods of food handlers and economic development, both in developed and developing countries.
- viii. Fact 8: Some harmful bacteria are becoming resistant to drug treatments**
- a. Antimicrobial resistance is a growing global health concern. Overuse and misuse of antimicrobials in agriculture and animal husbandry, in addition to human clinical uses, is one of the factors leading to the emergence and spread of antimicrobial resistance. Antimicrobial-resistant bacteria in animals may be transmitted to humans via food.
- ix. Fact 9: Everybody has a role to play in keeping food safe**
- a. Food safety is a shared responsibility between governments, industry, producers, academia, and consumers. Everyone has a role to play. Achieving food safety is a multi-sectoral effort requiring expertise from a range of different disciplines – toxicology, microbiology, parasitology, nutrition, health economics, and human and veterinary medicine. Local communities, women’s groups and school education also play an important role.
- x. Fact 10: Consumers must be well informed on food safety practices**
- a. People should make informed and wise food choices and adopt adequate behaviors. They should know common food hazards and how to handle food safely, using the information provided in food labelling.

Whether intentional or not, food scandals through outbreak of foodborne diseases is deadly not only to the consumer but also to the producer. The project seeks to address this problem by development of a system powered by blockchain technology to address some the facts mentioned above. By injecting transparent in the production line and supply chain, the consumer will be more informed about the food on his table. As mentioned on fact 6, food safety is a multi-sectorial and multi-disciplinary effort. The system will have these a multitude of different professionals; different governmental departments and agencies, encompassing public health, agriculture, education and trade are part of the system as stakeholders and will be responsible for validation and verification for transactions in the system via a consensus algorithm.

Blockchain through its decentralized database will store accounts and transactions between stakeholders (Swan, 2015). This functionality makes blockchain sometimes to be referred as public ledger. Yli-Huumo et al. (2016) state that every stakeholder or participant in the system, also known as node, has the complete and automatically updated list of records of the transactions on the blockchain from the very beginning and the list can be queried, making information about transactions retrievable and transparent.

### **1.3. Aim**

The aim of this study is to develop a system using block chain technology that will inject transparency, and decentralization in the supply chain to enhance food traceability and safety in Kenya.

### **1.4. Specific Objectives**

- i. To investigate the various actors and stakeholders in food supply chain in Kenya.
- ii. To analyse current techniques, models and technologies used in blockchain technology.
- iii. To develop a system that enhance food traceability and safety by employing block chain technology.
- iv. To validate that the block chain technology powered system to confirm that it enhances food traceability and safety by providing transparency to stakeholders and decentralization in the food supply chain.

### **1.5. Research Questions**

- i. What factors need transparency, accountability and distribution in the food supply chain?
- ii. What are the current techniques, models and technologies used in blockchain technology?
- iii. How a system that enhance food traceability and safety by employing block chain technology be developed?
- iv. How will the developed system that enhance food traceability and safety by employing block chain technology be tested?

## **1.6. Justification**

The system will have tremendous benefits to Kenyans, farmers and standardization agencies (government) (User, 2019). Food is a basic physiological need that every human being must have to survive (Maslow, 1943). This has made the food industry the most lucrative industry in the world with some companies having production and supplies across the globe. The industry therefore has potential of affecting so many people health wise should something go wrong in the production chain or supply chain. Food can become contaminated at any point during production, distribution and preparation. Everyone along the production chain, from producer to consumer, has a role to play to ensure the food we eat does not cause diseases. This is however, complicated by globalization. The system will be able to bring on board all players as nodes on the blockchain system. They will be able to validate transaction and view previous transactions that cannot be changed.

By ensuring the transparency and given that the database is distributed and can be accessed from anywhere on the globe, customers will be more informed about the safety of the food they are having on the table, the government will be able to track the source of food in case of an outbreak and everybody in the block chain will be able to receive this information and hence recall of infected food will be possible.

The system will do away with middlemen hence the farmers will be able to get the best value for their products', the consumers will not be extorted by middle men hence will get value for money. The farmers will not lose source of their livelihood every so often due to foodborne diseases. The standardization agencies and civil society will have an easier reference point platform for ensuring standards are met.

## **1.7. Scope and Limitation**

The scope of the study will be Kenya. The project will sought the views of the Kenyan farmers and the challenges that they have with the current production and supply chain of their produce. The project will seek the indulgence of the various ministries including ministry of Agriculture and Ministry of Trade on the challenges that they have with the current system and how they think implementation of the proposed system can help them serve Kenyans better. Finally the

project will engage Kenyan consumers on the view of the various food scandals and their opinion on how this scenarios acne be avoided in future.

The biggest limitation of the project is the scope; Kenya. Due to globalization, it's myopic to look at food production and supply chain at a national level. In fact most of the scandals mentioned above had international aspects in them. However, due to the level and time for this study, we will narrow down to the national level; Kenya as a country: the scope of this project will limit the study to Food safety in Kenya.



## Chapter 2 : Literature Review

### 2.1. Introduction

Food is a basic need not only for human beings (Maslow, 1943) but also to any living animal. However, if not checked, food system is vulnerable to natural and artificial adulteration and contamination. Because of the huge demand that food has, food have been weaponized in the past decades by way of destroying farms so that the enemy population could starve or get infected by foodborne diseases and infection (Lee, n.d.). This fear made the highest court on planet, the International Criminal Court (ICC), an Intergovernmental organization that prosecutes individuals for International crimes to pass a regulations stating ““Employing poison or poisoned weapons” constitutes a war crime in international armed conflicts under the Statute of the International Criminal Court.” (icrc, 2019).

The above mentioned shows the level of magnitude that food has on the daily lives of humans. However, ICC mandate is only international, and though regulations are good in checking practice, its implementation will come too late when the damage is already done: people have been poisoned and died already. Furthermore, customers would like to ascertain the quality of the food they are having at the table and to some ensure that the person who toiled (the farmer) to prepare the product get what is dully theirs.

### 2.2. Theoretical Framework

#### 2.2.1. Various Actors and Stakeholders in Food Supply Chain in Kenya

Agri-food chain is a complex network of input and output with the end product of food that consumers finally enjoys on their table. The food supply chain is made of processes (decision making and execution) and flow (material, information and money) that aim to meet the customers’ needs of food on the table (Jack, Carlos & Jacques, 2007). Looking at the chain at Macro scale, we can reduce the activities to agricultural activities, food processing, distribution and consumption. Looking at the supply chain at a micro-scale however, we can find a number of other players such as feedstock suppliers; agro-chemical manufacturers and suppliers; machinery and equipment manufacturers and suppliers; farmers; produce marketers and sellers;

food processors; suppliers of food additives; packaging suppliers; transport companies; food retailers; consumers; and waste processors. Other stakeholders who are worth mentioning include private and public research centres in the different subsectors of the agri-food sector. It has also to be considered that legal and regulatory requirements exert an influence in every link of the agri-food chain (Chain, Production, & Processors, n.d.).

Table 2.1 : Agri-food Chain Stakeholders in Various Sectors (Adapted from Chain, Production, & Processors, n.d.)

Stage	Agri-food chain link	Dairy Products	Cereal Products	Fruit & Vegetables	Meat Products
Raw material production	<b>Farm suppliers inputs</b>	livestock feed providers; fertilizer, pesticide, veterinary & agro-chemical manufacturers	seed providers; fertilizer, pesticide & agro-chemical manufacturers	seed providers; fertilizer, pesticide & agro-chemical manufacturers	livestock feed providers; fertilizer, pesticides, veterinary & agro-chemical manufacturers
	<b>Farmers</b>	livestock breeding	seed growers	horticultural production	animal husbandry
Processing stages	<b>Food Processors &amp; packagers</b>	dairy product manufacture: milk, yoghurt, ice-cream, powder milk, etc.	grain millers, bakeries, pasta manufacturers, breakfast cereal manufacturers	canned, dehydrated and frozen vegetable based packaged convenience foods manufacturers	abattoirs; butchers; canned, hydrated and frozen packaged meat based convenience foods manufacturers
Post processing stages	<b>Logistic</b>	Transport			
	<b>Retailers</b>	milkmen, super markets, grocery shops	bakeries, supermarkets, grocery shops	supermarkets, fresh fruit & vegetable markets, green grocers, grocery shops	butcheries, supermarkets
	<b>Consumers</b>	single to family households with various age groups lifestyles, cultures, preferences, incomes			

Such a complex supply chain as shown above marked by the complexity of globalization has resulted in several transparency and traceability related issues, thereby culminating in the preponderance of unethical, non-sustainable and socially irresponsible behaviour by some actors along the supply chain hence the need for a system that will enable traceability of the food from the farm to fork.

Furthermore, the International Federation of Organic Agricultural Movements (IFOAM) defines four principles that the organic food industry have to account for and this includes the principles of health, ecology, fairness and care; illustrates that the organic agricultural industry have its base on sustainability and social responsibility to all actors and stakeholders including mother earth (Jacob-john & Veerapa, 2015).

Jacob –john and Veerapa (2015) in their work classifies the food supply chain into four tiers as listed below:

- i. Tier 1 – The suppliers of inputs to the farmer and within the context of organic food supply chains includes suppliers of raw materials
- ii. Tier 2 – The farmers of fresh produce and are normally the custodians of the land. For the purpose of this work, this included only organic farmers who cultivated organic or sustainably grown produce.
- iii. Tier 3 – These are traders, service societies and exporting companies that are in charge of supplying to the final business customers. They get the products from the farmers and they sell it to the retailing organizations and as such, final business customers-businesses, which sell to the consumers.
- iv. Tier 4 – The final tier of the food supply chain involves the final business customers.

The above tiers interrelated as shown on Figure 2.1. The complex web of food production by a farmer. There are a number of players ion the web that are that contribute to the success production of food products and a slip by any of them could cause food borne diseases.

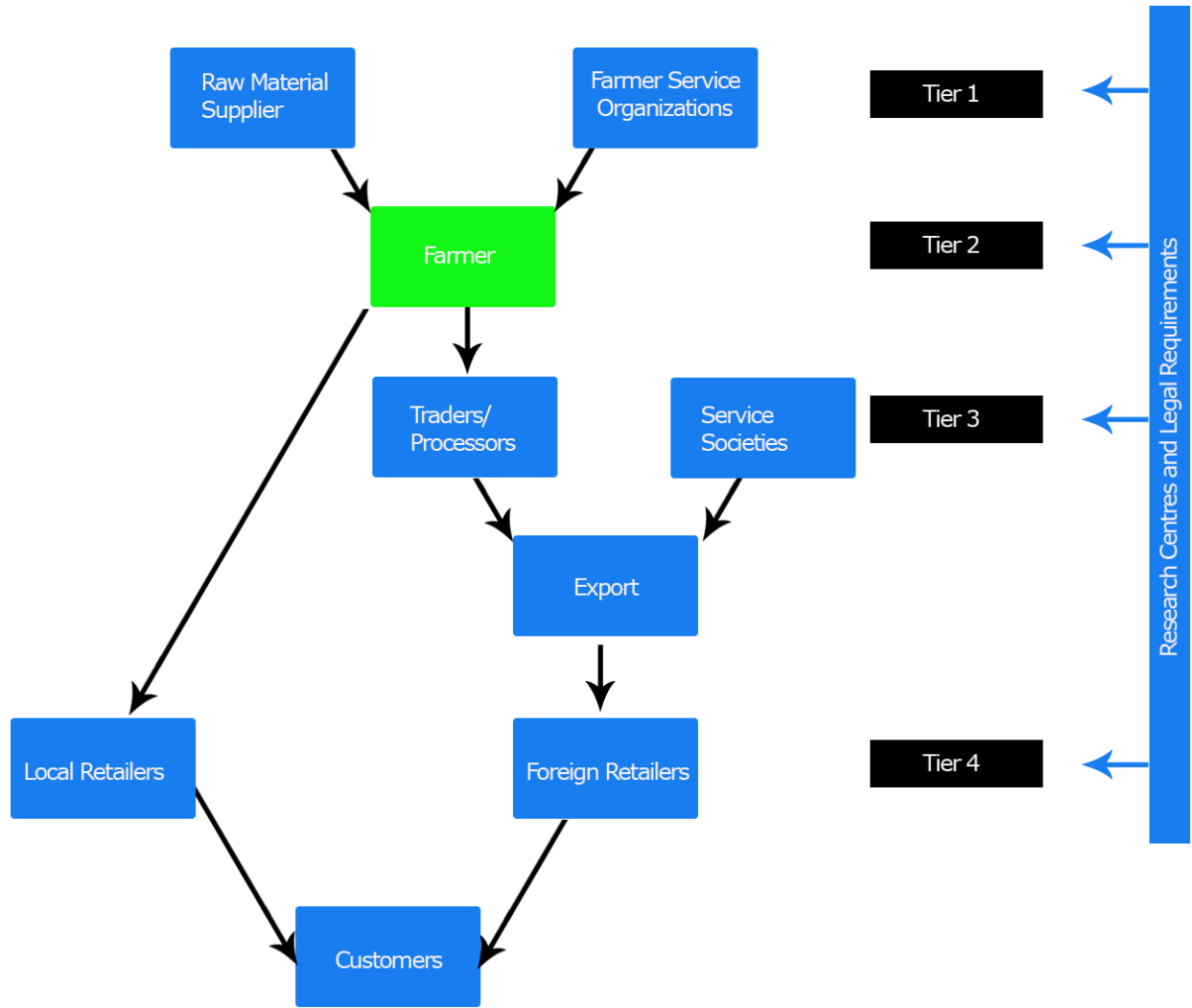

Figure 2.1 : Interrelation of Stakeholder in the Food Supply Chain (Adapted from Jacob-john & Veerapa, 2015)

As shown in the Table 2.1 and Figure 2.1, the supply chain must work as one single unit as gears do. Failure by one of the actors and the end product will lose quality and in worst cases, cause food borne diseases. Food and Agriculture Organization of the United Nations (FAO) (Jack, Carlos & Jacques, 2007) in their paper Agricultural Management, marketing and Finance Occasional Paper, titled Agro-industrial Supply Chain Management: Concepts and Applications, identifies two types of food supply chain:

- i. *Agri-food chains for fresh agricultural products*' (such as fresh vegetables, flowers, and fruit). The generally include growers, auctions, wholesalers, importers and exporters,

retailers and speciality shops and their input and service suppliers. With this type of supply chain, all of the stages mentioned above leave the intrinsic characteristics of the product grown or produced untouched. Main processes in this type include handling, conditioned storing, packing, transportation and especially trading of these goods.

- ii. *Agrifood chains for processed food products*' (such as portioned meats, snacks, juices, desserts, canned food products). With this type of chains, agricultural products are used as raw materials for producing consumer products with higher added value. Conservation and conditioning processes extend the shelf-life of the products.

The type of food chain has an impact on the logistic and Information Technology Logistics and Information and Communication Technology. Table 2.2 below delve into details of these impacts.





Table 2.2 : Overview of the main Characteristics of Food Supply Chain Networks and their impact on Logistics and Information and Communication Technology (Adapted from Van der Vorst et al., 2005)

<b>supply chain stage</b>	<b>Product and process characteristics</b>	<b>Impact on Logistics and ICT</b>
Overall	<ul style="list-style-type: none"> <li>• Shelf-life constraints for raw materials, intermediates and finished products and changes in product quality level while progressing the supply chain (decay)</li> <li>• Recycling of materials required</li> </ul>	<ul style="list-style-type: none"> <li>• Timing constraints</li> <li>• Information requirements</li> <li>• Return flows</li> </ul>
Growers / Producers	<ul style="list-style-type: none"> <li>• Long production times (producing new or additional products takes a lot of time)</li> <li>• Seasonality in production</li> <li>• Variability of quality and quantity of supply</li> </ul>	<ul style="list-style-type: none"> <li>• Responsiveness</li> <li>• Flexibility in process and planning</li> </ul>
Food processing industry	<ul style="list-style-type: none"> <li>• High volume, low variety (although the variety is increasing) production systems</li> <li>• Highly sophisticated capital-intensive machinery leading to the need to maintain capacity utilization</li> <li>• Variable process yield in quantity and quality due to biological variations, seasonality, random factors connected with weather, pests, other biological hazards</li> </ul>	<ul style="list-style-type: none"> <li>• Importance of production planning and scheduling focusing on high capacity utilization</li> <li>• Timing constraints, ICT possibility to confine products</li> <li>• Flexible production planning that can handle this Complexity</li> </ul>
Auctions / Wholesalers/ Retailers	<ul style="list-style-type: none"> <li>• Variability of quality and quantity of supply of farm-based inputs</li> <li>• Seasonal supply of products requires global (year-round) sourcing</li> <li>• Requirements for conditioned transportation and storage means</li> </ul>	<ul style="list-style-type: none"> <li>• Pricing issues</li> <li>• Timing constraints</li> <li>• Need for conditioning</li> <li>• Pre-information on quality status of products</li> </ul>

### 2.2.2. Current Techniques, Models and Technologies Used in Blockchain Technology

Speaking technically from Information technology perspective, the blockchain is a distributed replicated database that allows secure transactions between two entities without a central authority. However, looking at the term from a wider perspective, experts and researchers use this term to identify the whole technology ecosystem behind digital assets exchange among participants of the same network, with no intermediaries. (Miragliotta & Engineering, 2018). The entire system is decentralized, its transactions are automatically verified by users and the public ledger is secured through extremely strong encryption (Nakamoto, 2008). The infamous Bitcoin is a type of crypto currency transactions implemented through the new disruptive technology – blockchain (Antonopoulos, 2014). Table represents the main difference between Bitcoin, Legal Currency and traditional Online Payment.

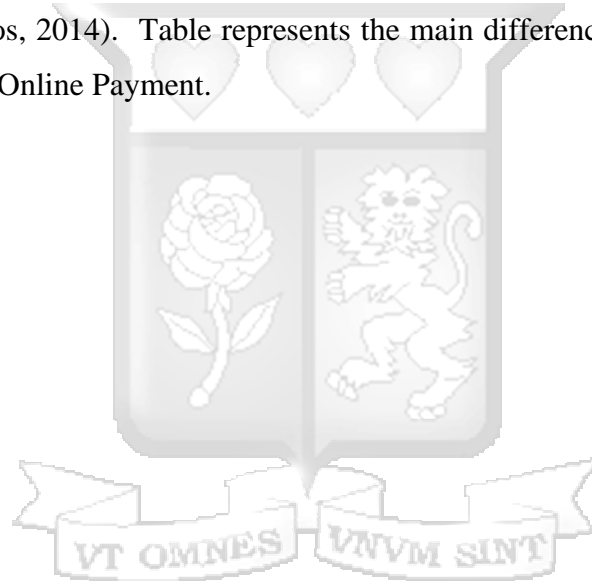

Table 2.3 : Comparison between Bitcoin, Legal Currency and Traditional Online Payments (Adapted from Miragliotta et al, 2018)

Characterisites		Bitcoin	Legal currency	Traditional online payments
Management	Issuer	Issued by the system	Government or banks	E-money service providers
	Manager	Managed by P2P network	Government or banks	E-money service providers
Value	Issuance cap	21 million BTC	None	Issued within the amount deposited in advance
	Grounds for value	Trust in the system	Trust in the government	Trust in a reliable third-party
Money transfer	Required time	A block is created every 10 minutes, the blockchain is considered authentic after the creation of 6 blocks, so the finalization time is of 60 minutes	Immediately in the case of direct receipt, a long time when there is the need to transfer money	Several days to one month, until payments to member stores are completed
	Transfer fees	Small amount sustained by senders	Expensive sustained or by senders or by the receivers	Sustained by the receivers
Anonymity	Anonymity of transactions	Transaction records are explicit but anonymous	High anonymity	Low anonymity
	Disclosure of transaction records	Disclosed	Undisclosed	Generally undisclosed

Most of the new products that are currently getting developed with the implementation of the blockchain technology is mainly from the financial sector to its existing business processes (Swan, 2015). According to Yli-Huumo et al. (2016), further research needs to be done on the scalability of blockchain application beyond crypto currency application of bitcoin, to achieve the expansion in industry use of the technology. This is where this work comes; to research on Block Chain Technology to Enhance Food Traceability and Safety; Case Study of Agriculture Industry in Kenya.

As mentioned earlier, blockchain technology is based on a distributed ledger system as illustrated in Figure 2.2 and can be seen as a verification system for digital transactions where data about a transaction, between members of the network, can be stored. The centralized system have one node/computer making the decisions. The other nodes connected to the main nodes just send in requests to be processed by the main node. The decentralized systems are a subset of distributed systems. With decentralized systems, decision is an aggregate of response from decision by each of the nodes. Distributed systems on the other hand have a shared processing across multiple nodes, but the decisions might be centralized. This is very vital to a system that's main aim is to increase transparency as every node will take part in a work process and be is a where of the contributions by other nodes,

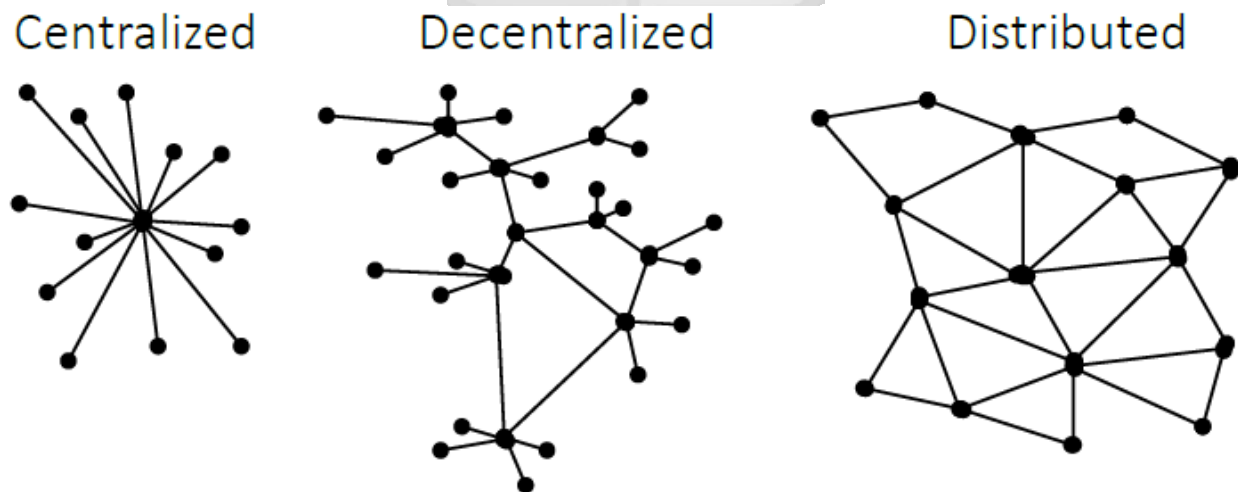

Figure 2.2 : Different Network Structures (Adapted from Holmberg, 2018)

### 2.2.2.1. Transaction definition

This is a message composed of the public address of the receiver, a cryptographic digital signature to prove the authenticity of transaction and, finally, the value of the transaction. Transactions are created and transmitted to the network by the sender. The system uses hash function to protect against the falsification of data in the transaction. This function provides to modify the hash value when there is also a little change in the data of transactions.

“Public-key cryptography” method has been adopted to protect the information of participants of the network. Each transaction has two different keys, one private, exclusive property of each participants, used to unlock the cryptocurrency fund; and the other public, like an e-mail address. These two keys allow to encrypt and decrypt the transaction (Miragliotta & Engineering, 2018). Figure 2.3 illustrates the use of public and private keys to verify transaction. This aspect of the blockchain will come in handy when transaction between various nodes in the system take place, for instance buying of agricultural produce/products by customers

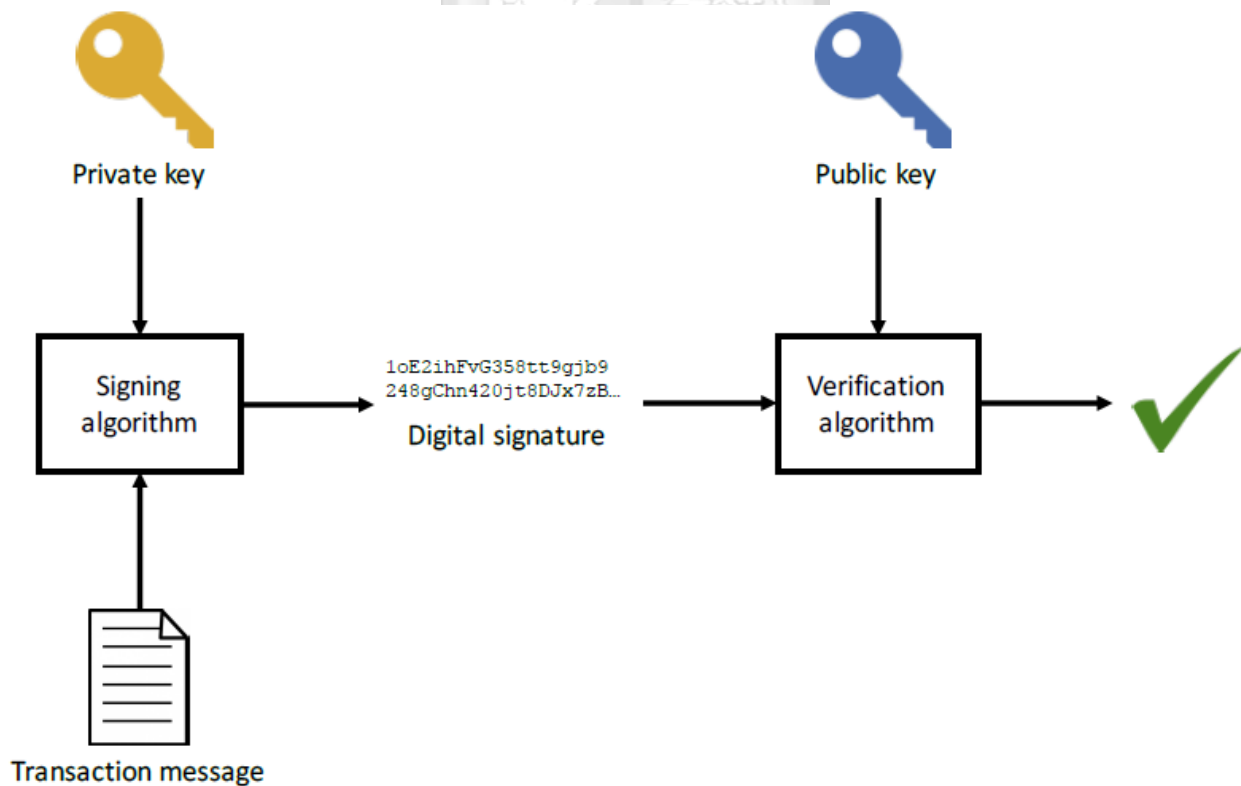

Figure 2.3 : Signing and Verifying of Transaction (Adapted from Pharmaceuticals, 2016)

The digital signature proves the authenticity of the transaction and it is made by encrypting the hash value of the data transferred with the sender's public key. This ensures the credibility of the information and that the right node will receive the information that was intended for them. This would also ensure that there is no sniffing or tapping of the information.

### 2.2.2.2. Transaction authentication

The nodes/users in the network receive the message, use the sender's public key to decrypt the digital signature and then verify the authenticity of the transaction. The nodes use the same hash function of the sender and create a new hash function and does comparison to check if the two values are the same: if it happens, they confirm the authenticity of the digital signature. This is followed by, transactions collection in an updated version of the database or ledger, called block (Miragliotta & Engineering, 2018). Figure 2.4 illustrates a cross section of blocks linked to a chain. The project implements block chain technology the development of the system to ensure no data corruption and data credibility.

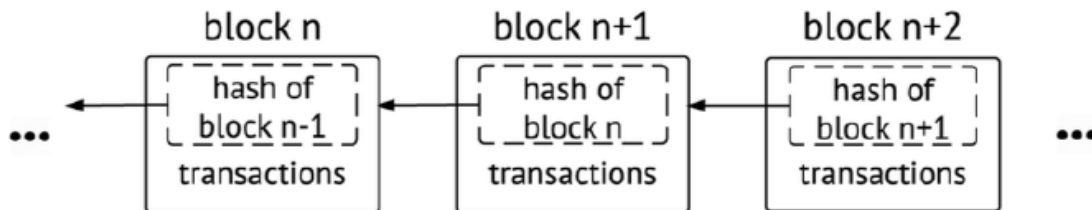

Figure 2.4 : Blocks Linked to Chain (Adapted from Pharmaceuticals, 2016)

### 2.2.2.3. Block Validation

Some nodes, designated for the validation phase, receive the block and start an iterative process of validation. The process of validation is called mining that is a consensus algorithm which validate transactions only if the 51 % of the network approves the authenticity. Each node of the network can be a validator node and this would mean that it has to offer its CPU power to solve the Hashcash algorithm to validate transactions.

Validator nodes are called miners and are rewarded if they succeed in the validation phase. The mechanism of validation is called Proof of Work (PoW) and consists on an iterative process which stops when the miner obtain a designated value. In detail, miners calculate a hash value by adding any given value to the collection of data arrived to them, and the process continues, adding other values to the transaction until the final hash value is smaller than the original. When a node succeed in the PoW, it transmits the block to the other nodes, and they have to confirm the correctness of the value and approve the transactions constituting the block (Miragliotta & Engineering, 2018).

#### 2.2.2.4. Block chaining

A new block is attached to the blockchain once all transactions are validated, and the blockchain is transmitted to the whole network. Transactions are time stamped and collected by the blockchain collects all transactions in a timely order. Each block contains the hash value of the previous block, and information of transactions are included in the actual block (Miragliotta & Engineering, 2018). Figure 2.5 illustrates structure of the blockchain.

In the project, a farmer/processing company is added as a user and hence a node after they have been certified by the government node validated by various relevant nodes. A processing company for instance would have to be validated by the government office responsible for company registration, relevant health environmental and health approvers and Kenya Bureau of Standards nodes.

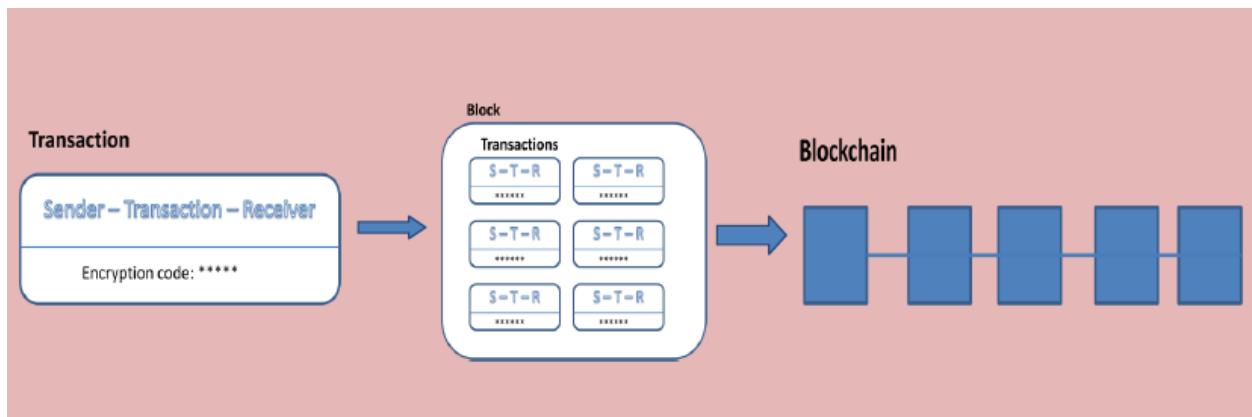

Figure 2.5 : Structure of blockchain (Adapted from Miragliotta & Engineering, 2018)

Kurki J.(2016) in her work on Benefits and guidelines for utilizing blockchain technology in pharmaceutical supply chains summarizes the process of accepting new as shown below:

- i. New transactions are broadcast to all nodes.
- ii. Each node collects new transactions into a block.
- iii. Each node works on finding a difficult proof-of-work for its block.
- iv. When a node finds a proof-of-work, it broadcasts the block to all nodes.
- v. Nodes accept the block only if all transactions in it are valid and not already spent.
- vi. Nodes express their acceptance of the block by working on creating the next block in the chain, using the hash of the accepted block as the previous hash.

Holmberg (2018) in her paper Blockchain technology in food supply chains lists down the essential parts of a Blockchain Technology as illustrated in Table 2.4.

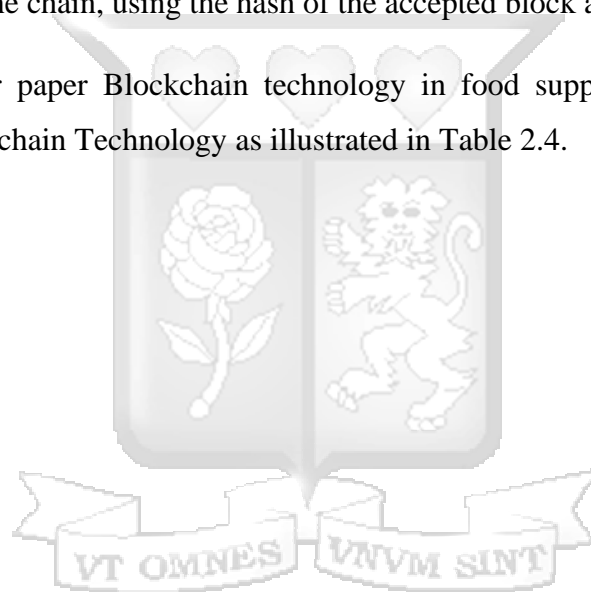

Table 2.4 : Essential Parts of Blockchain Technology (Adapted from Holmberg, 2018).

<b>Function</b>	<b>Type</b>	<b>Description</b>
Access	Private	A private blockchain is under the control of one organization and the members are those who satisfy certain requirements and get assigned different authorities. A private blockchain is rather centralized.
	Public	A public blockchain is open for anyone to join the network anonymously, take part of the records and be part of the consensus process (Lin et al. 2017). A public blockchain can be seen as a distributed network.
	Consortium	A consortium model is a model based on the benefits of public blockchain framework but a kind of private chain with well-known actors, so called permissioned actors (Gramoli 2017). In some cases, a hybrid version of blockchain could be called consortium.
Keys	Private	A private key is only known and seen by the owner node of the key and are used for access to the network, the nodes account and transaction confirmations (Kairos Future 2017).
	Public	A public key can be seen as an address to the specific node, for other nodes in the network to interact with that specific node (Kairos Future 2017).
Distribution architecture	Centralized	A centralized network outlines by all data to be collected and stored in one single point (Larsson & Korsfeldt n.d; Lin et al. 2017).
	Decentralized	A decentralized network outlines by the data to be spread out globally to

		several local databases. The ledger content is agreed upon by all member nodes by using a consensus protocol
	Distributed	A distributed network outlines by a number of copies of data that is held by several nodes in the network. In the case of Bitcoin all nodes hold a copy of all transactions (Pehrson n.d).
Consensus protocols	Proof of Work	<p>PoW is the consensus protocol used by e.g. the Bitcoin blockchain network. The confirmation process of transaction is made by performing a work-intensive task using information from the existing blockchain, called “mining”. In the case of Bitcoin, a block contains of a nonce.</p> <p>The PoW process in the case of a Bitcoin transaction includes scanning for a value to be hashed. The hash begins with a certain number of zeros and the PoW outlines by a miner incrementing a nonce to the block until reaching less or the certain number of zeros.</p> <p>When a satisfying nonce is found, a hash difficult enough is found and the block can be added to the chain. When a miner has found a solution, that node will broadcast it for the rest of the network whom will accept the block only if all the transactions in the block are valid.</p> <p>The network shows their acceptance by start solving next block in the chain, using the hash from the accepted block. This is an extremely difficult, time and energy consuming process. (Investopedia 2018b; Investopedia 2018c; Ray 2017; Nakamoto 2008).</p>
	Proof of	PoS outlines by validators that “mints” or “forges”. The chances of being the

	Stake	<p>one validator to create and validate a block is linear with the amount of coins in their crypto wallet- the more coins in the wallet the higher the chance to validate. A wallets size compared to the networks value is the wallets stake. The bigger stake a validator has, the bigger chance it is to solve the puzzle. The validation process starts with the validator to put their wallet in risk to the network, when the wallet is set at risk they are able to approve a transaction. The one with the biggest stake will most likely win the puzzle. The validators get rewarded with transaction fees. If the approval of a minter or forger is not valid, the minter or forger will lose its wallet. (Cryptonouts 2017; Simply Explained - Savjee 2018; Zheng et al. 2017).</p>
	Practical Byzantine Fault Tolerance	<p>PBFT is an algorithm that tolerates byzantine fault in an effective way. The nodes in a network are called replicas, where the used node is called primary and the others of the network are called backup. In order to confirm a transaction, the PBFT goes through three stages; preprepare, prepare and commit. The three stages are outlined as a message log. The algorithm starts with a client to send a request to a replica who then becomes the primary. At the same time the three stage protocol starts. The pre-prepare stage is sent to the other replicas in the network without the actual request information included, in order to confirm that the request is valid. The backup confirms the pre-prepare stage and the prepare stage is triggered. The prepare stage is valid if it matches pre-prepare messages which is checked and confirmed by both the backup and the primary. Once confirmed it is added to the protocol log and</p>

		triggers the commit stage. Replicas confirm the commit message and adds it to the protocol log. When the commit is confirmed a reply will be sent to the client. (Castro & Liskov 1999; Colyer 2015).
Optimizing	Merkle tree	<p>A Merkle Tree is a data structure that in cryptocurrencies like Bitcoin is used to more efficiently and securely encode blockchain data. Instead of running the entire block of transaction data through the hash function, each transaction in the block is hashed and then paired with another transaction and hashed together, and so on until there is one hash for each block, called the Merkle Root (Investopedia 2018a).</p> <p>Thus, the Merkle Root is the resulting hash of all the hashes that has been made of all the transactions that has been done in a block, see figure 4. The Merkle root is updated every time a new transaction is accepted (Bitcoinwiki 2015). Merkle Trees are useful because</p> <p>verification of a specific transaction can be done without having to download the whole blockchain, instead verification can be done by only having to look at the associated</p>

### 2.3. Empirical Review

Tian (2018) on their paper dubbed “An information System for Food Safety Monitoring in Supply Chains based on HACCP, Blockchain and Internet of Things” attempts to build a system that would guarantee food safety and quality using the internet of things and blockchain technologies, to build a decentralized information system that could provide an information platform for all supply chain members (including government departments and third-party regulators) based on openness, transparency, neutrality, reliability and security. The researcher bases the work on the logical structure illustrated on Figure 2.6.

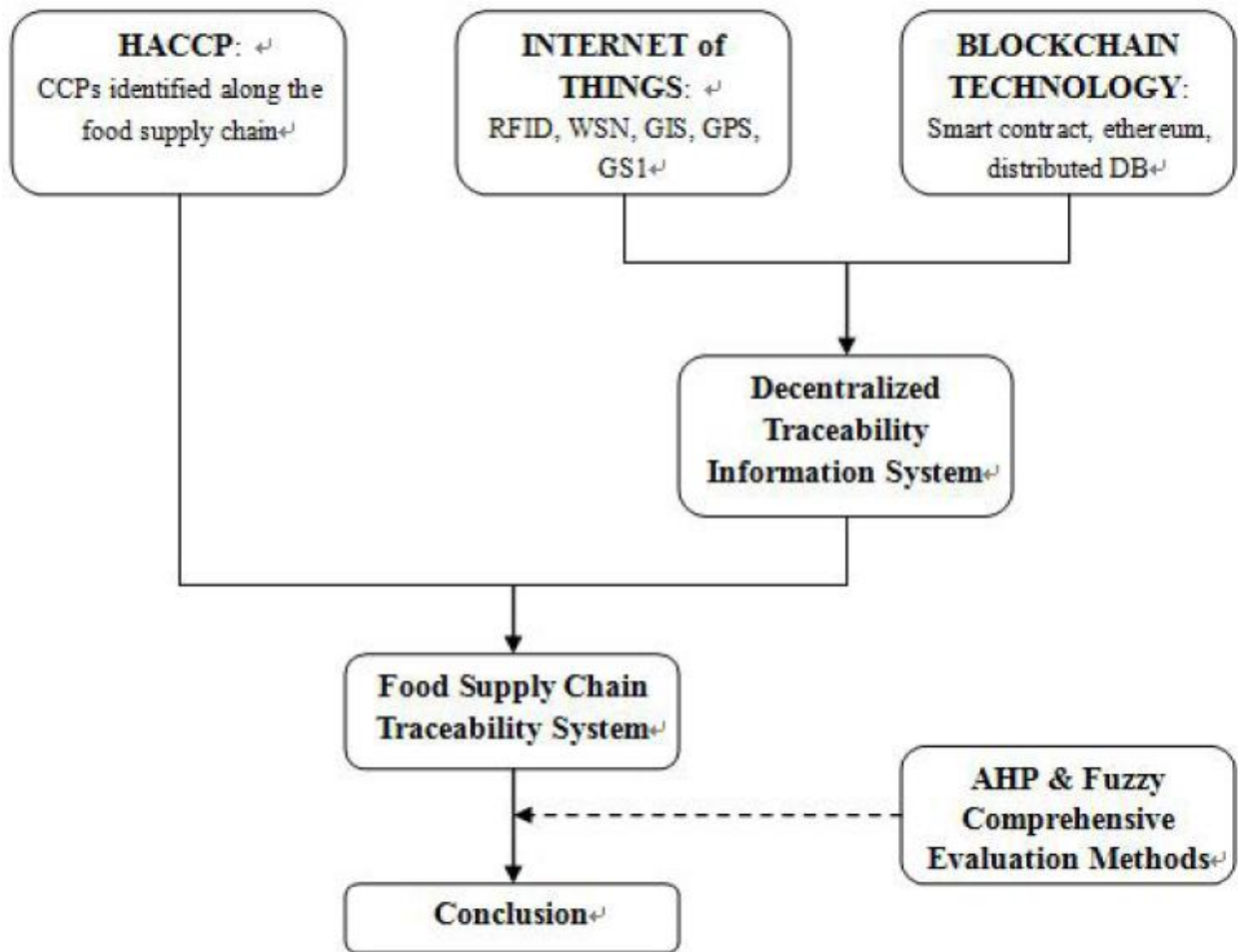

Figure 2.6 : Basic Logical structure of the Whole Research (Adapted from Tian, 2018)

The researcher employs various technology to monitor and give transparent in the food chain from the farm to fork. This way the research try to solve the complex food supply chain problem

by using GPS system for tracking transportation of food products; Radio-frequency identification(RFID) to automatically identify and track tags attached to food products package; and blockchain for information gathering and smart contracts. Figure 2.7 illustrates the conceptual framework Agri-food Supply Chain Traceability System Based on RFID & Blockchain Technology as envisioned by Tian (2018).

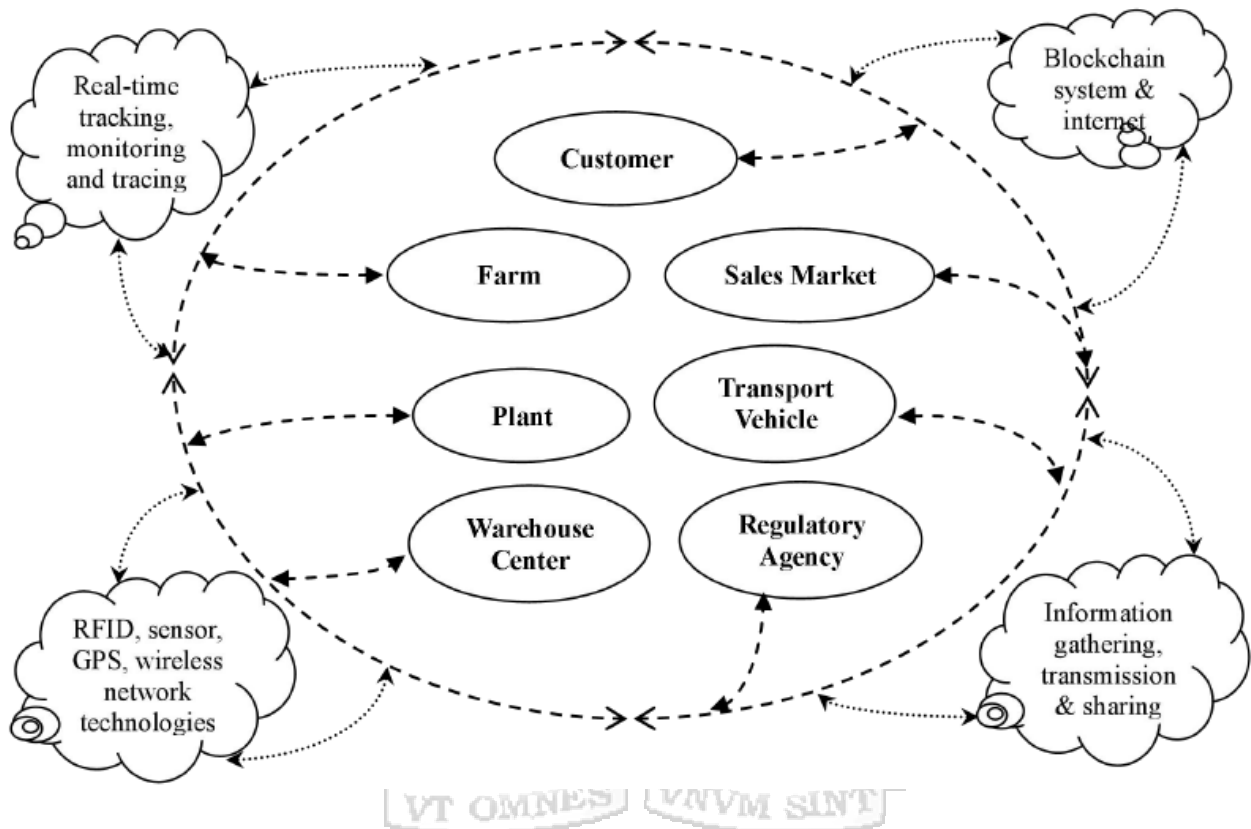

Figure 2.7 : Conceptual Framework of an Agri-food Supply Chain Traceability System Based on RFID & Blockchain Technology (Adapted from Tian, 2018)

Holmberg (2018) in her work “Blockchain technology in food supply chains” investigates the challenges and possibilities of a possible implementation of a traceability system supported by blockchain technology. The research focusses on the case study of a food supply chain for a package of milk, starting at the dairy manufacturer and ending at the retailer. The research draws a possible framework for an integration of blockchain into the case study supply chain. The framework is based on the empirical findings together with findings from the theory.

As explained in section 2.4.1, each actor registers themselves on the network with their private key and uses the public key for authorization and identification (Kairos future 2017). There is a

choice of data entry being done either manually or automatically by the actors in the network or supply chain by authorizing themselves with their private key on hardware devices connected to a software application providing an interface for the new data.

The framework proposes a layer of blockchain which is connected to all of the FSC members Master of Administration software. The new layers on top of the existing layers collect, connects and manages relevant product information through the supply chain. Each product would essentially be provided with a unique digital summary that is updated along the supply chain containing all relevant information gathered through the supply chain. The blockchain will further be connected to a global database, available to all members in the supply chain. The framework is illustrated in the Figure 2.8.

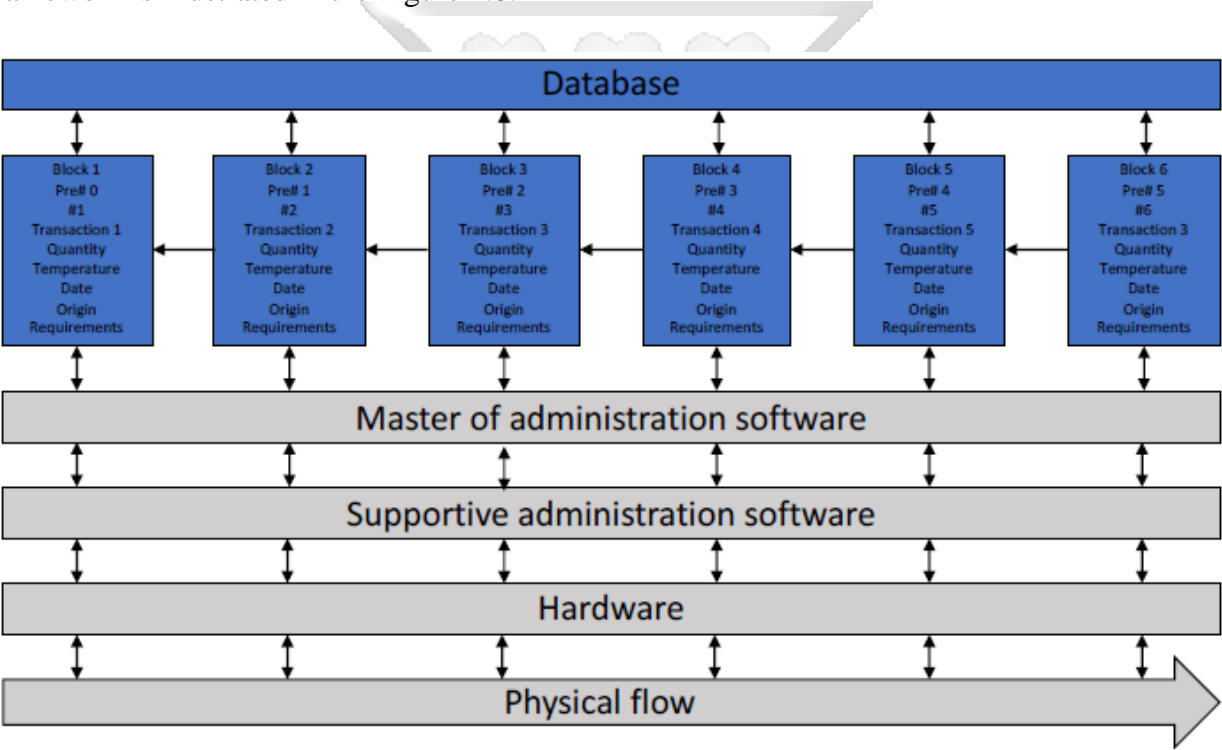

Figure 2.8 : The Proposed Framework of a Blockchain Supported Traceability System (Adapted from Holmberg 2018).

The researcher however concludes the work by stating that the blockchain technology still is immature in the context of food supply chains and some of the biggest challenges are to develop a culture that promotes collaborations, information sharing and standardizations which are easy to adopt. She however thinks that blockchain technology has the possibility to offer secure and

transparent traceability characteristics to a traceability system and a framework can lead to both cost and environmental savings in case of a product recall.

## 2.4 Conceptual Framework/Proposed Architecture

Holmberg (2018) describes a smart contract as “a software which can automatically trigger certain functions to take place when something predetermined event is happening.” Figure 2.9 displays a possible smart contract and its interaction with the blockchain. The requirements are stored in “contracts” and have to be fulfilled by the users to enable the creation of a new block. A smart contract is not a part of the blockchain protocol itself, but a feature performed on the blockchain which is stored in a completely distributed manner on a blockchain database(Holmberg, 2018).

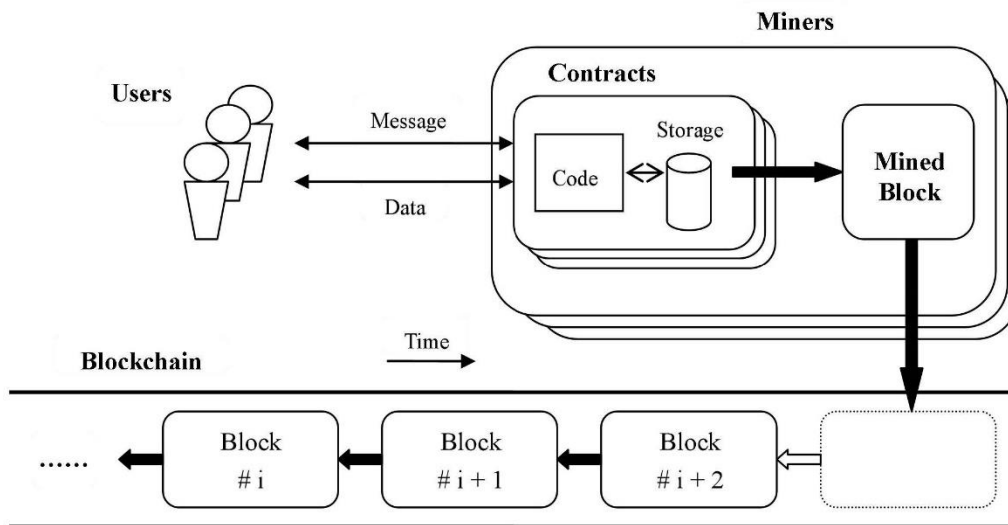

Figure 2.9 : Conceptual Framework of a Blockchain-based System with Smart Contracts  
(Adapted from Tian, 2018)

## Chapter 3 : Research Methodology

### 3.1 Introduction

This work seeks to solve the challenges within the food supply chain to increase transparency and accountability and thus increasing food safety and quality from farm to fork by developing a system powered by Block Chain Technology to Enhance Food Traceability and Safety in Kenya. This chapter outlines the methods that the paper will use to answer research question and achieve the research objectives. The section defines the target group of the work, the sample size and how the data will be collected and analysed. System methods implementation is looked at this chapter deeply by delving into system architecture, analysis and design and finally how it will be implemented.

### 3.2 Agile Software Development Methodology

The project will use agile development methodology to develop the system. Agile is an iterative, incremental and adaptive methodology for software development. This methodology is believed to have virtues like enhanced flexibility that allow for incorporation of evolving requirements, incremental delivery, quick time to market and ability to keep pace with market trends as compared to the traditional methods (Kaur, Jajoo, & Background, 2015). Agile methodology being the below concepts into the development of the system:

- i. Flexibility – changes can be suggested and made at any stage of development;
- ii. Collaboration – the emphasis is more on team work between the stakeholders and people are more important than instruments;
- iii. Communication is vital
- iv. Minimization of documents allows to devote more time to much more important things like testing and revising the version the project (Patel, 2019). Figure 3.1 Illustrates Agile methodology where, the development will go through a number of iterations until acceptable system is deployed for the customer

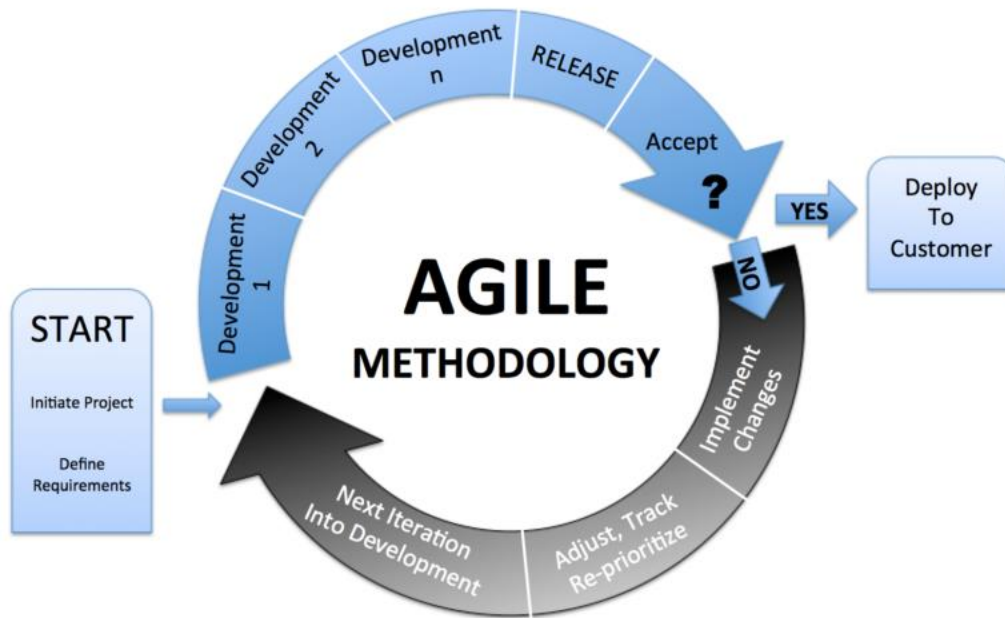

Figure 3.1 : Agile Methodology (Adapted from Patel, 2019)

Generally agile have 4 main values and 12 principles that eased frustration from the waterfall method. The four values that are people-centric and result driven are:

- i. Individuals and Interactions over Process and Tools
- ii. Working Software over Comprehensive Documentation
- iii. Responding to change over Following Plan
- iv. Customer collaboration over Contract Negotiation (Bauer, 2019).

The iterative nature of the system will allow the system to be tweaked to the needs of the stakeholders and ensure that the final product is a product that in deed will solve the issue on the ground. With traditional method, the project method could fail like me many others did. The traditional method accounted for 89% of software development failure (Sutherland, 2019).

### 3.3 Research Design

The project will use a mix of qualitative and quantitative design. The qualitative part will be employed while talking to the farmers, the customers and government. To find out the challenges that they are currently going through in terms of the agri-food Supply Chain. The descriptive

design, a subset of quantitative research design is used to understand the how, when and where of the project. This helps in identifying the characteristics, trends and correlation of various variables.

### 3.3.1 System Architecture

The system encompasses the model; the user interface and the blockchain database. Unlike other models, Rosic, (2019) believes blockchain system are unique because of the below reasons:

- i. Security: blockchain system should be a fortress because the code is open and public, meaning the code can be looked at by programmers online. However they should not be able to hack into the system due to the transactional nature of blockchain.
- ii. Resource Management: The system should be developed to use the resources as efficient as possible given that the architecture of the system is peer to peer and hence there is a lot of replication and cryptography processing taking place in the network.
- iii. Performance: The blockchain must always perform at its highest possible capabilities, given that there are certain tasks in the blockchain which are parallelizable whilst there are some tasks which can't be done in parallel. For instance, a "parallelizable" task is digital signature verification. All that you need for signature verification is the key, transaction and the signature. With just three data you can conduct verifications in a parallelized manner.
- iv. Isolation: All transaction operation in in blockchain must be deterministic by ensuring consistency in behaviours of operations for instance it should not be possible to have smart contracts that work in two different ways on two different machines. This is achieved by isolation by isolating smart contracts and transactions from non-deterministic elements.

For the above four reasons, php will be used to develop the system model. Javascript will be employed to bring interactivity in the user interface that is built on HTML 5 and styled using Cascading Style Sheet (CSS3). The dynamic data such as username and password are stored in MySQL database. The transactions however will be saved to the persistent blockchain which uses Ethereum smart contracts to store the data. Figure 3.2 illustrates a typical transaction

process in a blockchain system encryption and distributed system of nodes employed to protect data integrity.

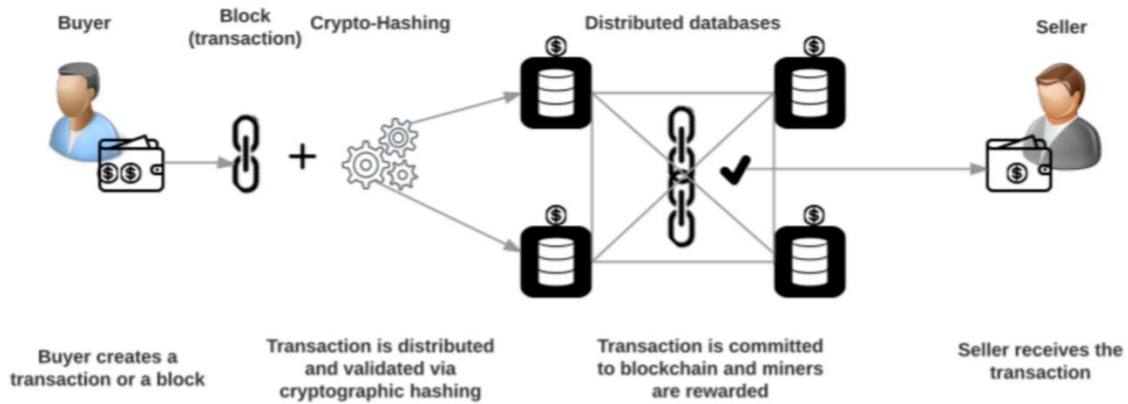

Figure 3.2 : Blockchain Process (Adapted from Commons, 2017)

### 3.3.2 System Analysis

The project uses Unified Modelling Language (UML) in describing the object-oriented concepts of the system throughout the software analysis and design process. The UML is a formal language for describing object-oriented concepts and relationships. The language’s main strength is its visual prowess and capability to communicate everything from the requirement analysis to methods and objects to be implemented in code (Wong, 2002). Figure 3.3 illustrates the process of coming up with technical documentation, from requirements to technical documentation.

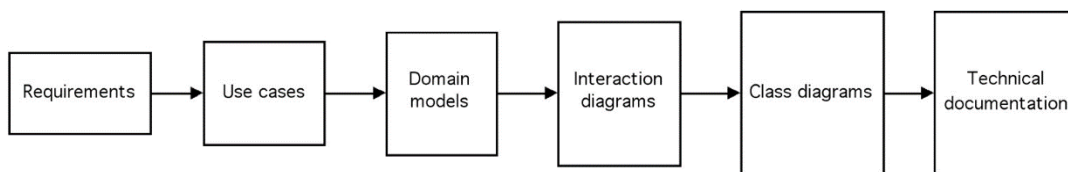

Figure 3.3 : Object-oriented Analysis and Design (OOAD) Artifacts (Adapted from Wong, 2002)

### **3.3.3 System Design**

As mentioned in section 3.3.2, the work employs unified modelling language in the analysis and the design phase by describing the object oriented concept to guide the development of the system. The project develops Context Diagrams, Use Case Diagrams, Sequence Diagrams as well as Data Flow Diagrams to bring out the objects, model business process and the system architecture of the system and how the information flows in the system. All these diagrams are illustrated and described in chapter four of this work.

### **3.3.4 System Implementation**

The model of this project will be developed using C++ as the language of choice due to the factors identified in section 3.3.1 of this work. The system will be implemented as a public blockchain system that can give access to everyone, in Kenya as anyone within Kenyan borders who eat Kenyan agri-product is a stakeholder. The system will have each node on a public blockchain to have as much transmission and receipt power as any other, they it will be fully distributed: Kindly see Figure 2.2.

The user interface will be developed to match the user type and hence the intuitiveness of the user interface might be different per each user. A farmer may not be as IT savvy as an agricultural analysts sitting in an NGO office and hence the design of the user interface will vary per user. The system will be responsive to adapt to various screen size by utilization of HTML 5, CSS 3 and JavaScript.

### **3.3.5 System Testing**

The project will use various testing techniques to validate various aspects of the system. Agile in itself is a test intensive methodology where each module is verified for its functional as the development continues. Specifically as identified in the document quality assurance, quality control and testing(Control, n.), the author(s) identifies various level of testing: Component/Unit Testing; Integration Testing; System Testing; Acceptance Testing. This work will run test at the identify level by employing the below types of tests. Table 3.1 compiles a list of the of tests that are used in information technology project (Control, n.).

Table 3.1 : Types of Tests Used in the Project (Adapted from Control, n.d.)

Testing type	Object	Levels of testing
<b>Functional Testing</b>	Testing software functions	All levels
<b>Use case Testing</b>	Checking that the path used by the user is working as intended	User acceptance System Integration
<b>Exploratory Testing</b>	Validating user experience	User acceptance System
<b>Usability Testing</b>	Checking that the system is easy to use	User acceptance System
<b>Security Testing</b>	Protecting the system	System

### 3.4 Target Population

Kenyan food supply chain is no different and hence include the players identified in chapter two of this work namely; agri-products raw material suppliers, agri-products farmers, food processors & packagers, retailers, consumers, pressure groups (NGOs), and policy enforcers (government). Others in the supply chain include farm input manufacturers such as; pesticide manufacturers, fertilizer manufacturers and seed companies; warehouse providers and transport/logistical players.

Agriculture is the backbone of Kenyan economy, contributing 26 per cent of the Gross Domestic Product (GDP) and another 27 per cent of GDP indirectly through linkages with other sectors. This sector alone employs more than 40 per cent of the total population of around 39.5 million (in 2011) and more than 70 per cent of Kenya's rural people. As mentioned in above agriculture in Kenya is large and complex, with a multitude of public, parastatal, non-governmental and private sectors (FAO, 2019). FAO attributes 65 per cent of the export earnings to the sector, and believes that the sector provides livelihood (employment, income and food security needs) for more than 80 per cent of the Kenyan population. (FAO, 2019; German, 2015).

### **3.5 Sample Techniques and Sample Size**

As mentioned on section 3.4, there is no exact number of farmers as majority of almost 40 million Kenyan are involved in farming in one way or the other. Secondly, they are dispersed all over the country and they are of diverse nature; from sugarcane growers of western Kenya to flower farmers in Naivasha to Sisal growers of Taiata Taveta and coffee farmers of central Kenya. We have rice farmers in Mwea to Miraas Farmers in Meru. The landscape of farming is diverse in Kenya.

Because of the above reasons, the project used convenient sampling together with purposive sampling to target the population that will be interviewed for this project. Both techniques are non-probabilistic sampling method. Convenience sampling (also known as Haphazard Sampling or Accidental Sampling) is a type of nonprobability or non-random sampling where members of the target population that meet certain practical criteria, such as easy accessibility, geographical proximity, availability at a given time, or the willingness to participate are included for the purpose of the study while the purposive sampling technique, also called judgment sampling, is the deliberate choice of a participant due to the qualities the participant possesses (Etikan, 2017).

Convenient sampling is used to sample the Kenyan farmers while purposive sampling is used to sample the other stakeholders in the food supply chain such the parastatals, the Non-Governmental organizations, the public office and the food processors/wholesalers. Though they are all stakeholders in the project, they come with unique and different characteristics that must be considered by the project hence the difference in sampling methods.

### **3.6 Data Collection Procedure**

The data will be collected by use of questionnaires that will be given to the sample population to get their views on various issues in regards to the food supply chain in Kenya. The advantage of using questionnaire is that, same question will be given to different people from diverse background. This will help in identifying if farmers from different regions of the country have same issues or fears or are going through the same problems across Kenya

### **3.7 Data Analysis Procedure**

The project will use SPSS in analysing the data collected from the questionnaires. This work heavily relies on the feedback that will be received from sample population and as such the data collected should give the correct information as the population intended it to be. This can only be achieved by accuracy of a computerised statistical package that allows for many different types of analyses, data transformations, and forms of output that is provided for by Statistical Package for the Social Sciences (SPSS) (Arkkelin, 2014).

### **3.8 Research Quality Aspects**

Work from Focus, technical brief 9 (Matters, 2004) defines research quality as “Quality research most commonly refers to the scientific process encompassing all aspects of study design; in particular, it pertains to the judgment regarding the match between the methods and questions, selection of subjects, measurement of outcomes, and protection against systematic bias, non-systematic bias, and inferential error (Boaz & Ashby, 2003; Lohr, 2004; Shavelson & Towne, 2002).”

#### **3.8.1 Validity**

Boaz and Ashby (2003) tries to elaborate this aspect by posing the question “does it measure what it says it does?” This work starts by defining the objectives and identifying the research questions. The amount of literature reviewed and the target group interviewed formed the foundation of this work and thus the centre of the validity of this research work. At the end of the project, the research question of the work is answered and recommendations are made given the findings of the project.

#### **3.8.2 Reliability**

Laerd (2019) dissertation defines reliability “as a way of assessing the quality of the measurement procedure used to collect data in a dissertation.” (Laerd, 2019). This paper covered the requirement by using questionnaires that carried same questions to different sample of the

population. This way, the work gets answers to the same question from different people hence repeatability of research.



## Chapter 4 : System Design and Architecture

### 4.1. Introduction

In this section the project delves into the technical aspects of the block chain technology to enhance food traceability and safety. In this chapter, the system functionalities requirements are defined to guide the development of the system. The non-functional requirements are identified and outlined. This process is largely guided by the stakeholders feedback received from the questionnaires that the project issued out to the stakeholders.

The system is broken down to smaller units of database, the logic and infrastructural needs. The various units are then further discussed and decomposed to give a better insight on the interaction and interrelation of these units for better understanding of the requirements and thus development of the modules.

### 4.2. Data Analysis

Questionnaires was the tool used to collect data for the project.’ This was done via a one on one interview process that saw the project gather more insight by way of respondents describing the situation further. This information was taken down in form notes for the qualitative part and in form questionnaire for the descriptive part.

Twelve respondents from each category; Farmers, Customers of Farm Produce and Food Processing companies took part in the one on one interviews and thus providing information for the questionnaires. The main aim of the questionnaire was to find out how effective the current system are in tracking a food born disease; where are the shortcoming and how the blockchain system can help mitigate these shortcomings. The data from questionnaire informed the system requirement of the system

#### 4.2.1 Degree of Response

For a full-fledged project – not scope of the study, the target population would be much wider; spanning from manure manufacturer to seed companies; from veterinary services to food

processors down to consumers. However, due to the limited time and scope of this project, the main target population was narrowed to Farmers, Customers of Farm Produce and Food Processing Companies. Below is a summary of the respondent's responses.

#### 4.2.2 Farmers

##### 4.2.2.1 Respondents details

Of the farmers interviewed; 58% were of the male gender while 42% were of female gender. Only 8% of the respondents were above 50 years of age; 75% of the respondents were of the age 31 to 50 years of age. 17% of the respondents were below the age 30. 38% of those who provided feedback were graduates while respondents from primary and secondary level counted for 31% of the respondents. 67% of the respondents indicated that they use organic manure while 33% of the farmers responded to using industrial manure.

##### 4.2.2.2 Whether Farmers Use Mobile Service Delivery to Market and Check Pricing Information

Star rating was employed to measure the level of acceptance of the various factors that are critical in transparency, accountability and distribution in the food supply chain. In the above mentioned question; an average of 2.5 star rating was recorded as is illustrated in Figure 4.1. This meant that mobile devices are fairly used by farmers in marketing.

5★	0
4★	2
3★	2
2★	8
1★	0
Average rating	2.5
Total votes	12

Figure 4.1 : The Average Rating for the Level of Embracing of use of Mobile Service Delivery to Market and Check Pricing Information

### 4.2.2.3 Whether Farmers Use Tagging of the Produce (RFID/Bar Code) For Tracking Information

The question was meant to seek farmer's level of use of tagging as a method for tracking their farm produce. The question received a star rating of 3.17 as illustrated in Figure 4.2. This meant that many farmers tagged their produce or used bar coding as method of labelling their products for sale.

5★	0
4★	3
3★	8
2★	1
1★	0
Average rating	3.166667
Total votes	12

Figure 4.2 : The Average Rating for Level of Use of Tagging of the Produce (RFID/bar code) by Farmers for Tracking Information

### 4.2.2.3 Whether Farmers Have a System to Capture the Source of Manure and Water Usage

The question sought to find out if farmers had a system in place to capture the source of the manure of water usage. The question got a below average rating of 2.1 as illustrated by Figure 4.3. This meant that more than half of the farmers did not have a system in place to monitor the source of manure/fertilizer or use of water in their farms. Whether they would use such a system if it existed would be another question al together.

5★	0
4★	0
3★	3
2★	8
1★	1
Average rating	2.166667
Total votes	12

Figure 4.3 : The Average Rating for Level of Use of System to Capture the Source of Manure and Water Usage

#### 4.2.2.4 Whether Farmers Have a System to Capture the Details of the Wholesaler Who Collects Their Produce

The question sought to establish if the farmers had a system in place to capture details of the wholesalers who collected their produce. The average rating from the response was 2.58 which is just slight above the average as is illustrated in Figure 4.4. This would show that few farmer care to note who has collected their produce hence it is a challenge to recall a defective product or to trace produce to the consumers

5★	0
4★	1
3★	7
2★	2
1★	2
Average rating	2.583333
Total votes	12

Figure 4.4 : The Average Rating for Level of Use of System to Capture the Details of the Wholesaler Who Collects Farmers Produce

#### 4.2.2.5. Whether Farmers have Strategies to Control Foodborne Pathogens in their Farm

The question sought to find out if already ways or strategies of controlling foodborne pathogens in their farms. The question scored an average of 2.58 on the rating scale as illustrated in Figure 4.5. This showed that half of the farmers did not have strategies of controlling these pathogens on their farms. It could also mean that since there are ineffective oversight bodies, farmers to feel compelled to have these strategies in place.

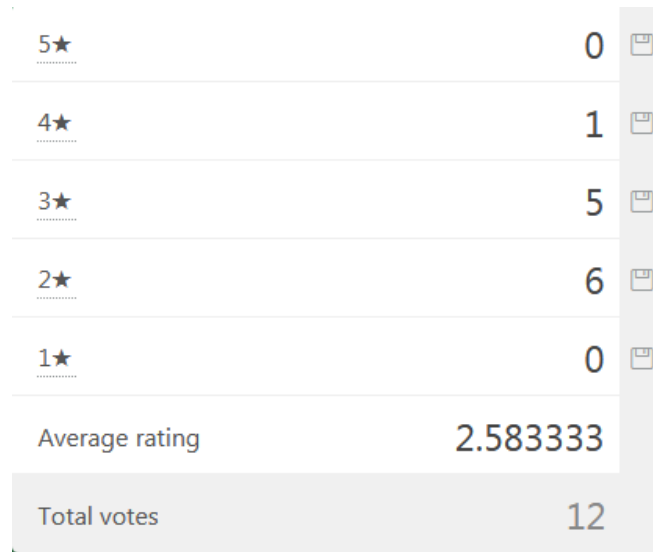

Figure 4.5 : Average Rating on the whether the Farmers have Strategies to Control Foodborne Pathogens

On the preceding questions which appeared on Section C of the questionnaire, the project sought to find the views of the farmers in regards to current approaches used to enhance food traceability and safety. These were more of qualitative question that sought views of farmers considering that they came from different background, dealt with different agri-products and had different economic muscles.

#### 4.2.2.6. What Approaches the Farmer Uses to Ensure their Produce are Traceable and Safe

The question sought to find out from options of three with a window to specify any other approach that they use to enhance food traceability and safety. The options were Produce Inspection, Produce Audit, Produce Recall and Enforcement. 71% of the farmers indicated the

use of Produce inspection while the remaining 29% uses Produce Recall an Enforcement a shown on Figure 4.6. The process basically relied on the farmers’ goodwill and their self-defined good practices.

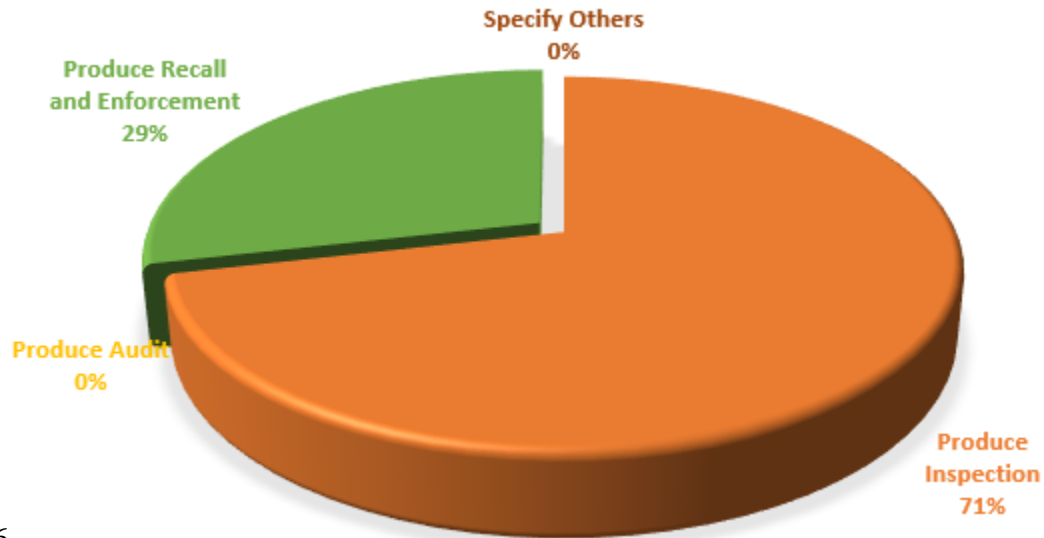

4.6

Figure 4.6 :Approaches the Farmers Use to Ensure their Produce are Traceable and Safe

**4.2.2.7. Considering the Approaches Selected Above Only, Rate the Same on the Effectiveness in Enhancing Food Traceability and Safety**

The question sought the views of the farmers on which approach they thought was the most effective given their choices above. Though, produce recall had registered the list votes of farmers that use this method, the farmer that use it believe that it’s far much more effective. The ratings are shown on Table 4.1. However, its implementation would be a challenge given that most farmers do not note which wholesaler ought their produce.

Table 4.1 : Table Showing the Average Rating of the Effectiveness of Approaches Selected by Farmers

Approach	Average Rating
<b>Produce Inspection</b>	<b>2.7</b>
<b>Produce Audit</b>	<b>0</b>
<b>Produce Recall and Enforcement</b>	<b>3.3</b>
<b>Approach Specified</b>	<b>0</b>

#### 4.2.2.8. Rate the Challenges You Have Experienced with Produce Traceability and Produce Safety

The question meant to seek the extent of challenge the farmers have in regards to produce traceability as compared to produce safety. Produce traceability got an average score of 3.08 rating while produce safety averaging 2.58 as shown on Table 4.2. This showed that most of the farmers had challenges with produce safety than produce traceability. This could mean that farmers do not know or have tools or support system that will help them handle food safety. Food traceability though got a higher rating does not mean its winning. Implementing food traceability if you cannot trace who bought your products is a different ball game.

Table 4.2 : The Average Rating for Level of Challenges Farmers have Experienced with Produce Traceability and Produce Safety

Challenges	Average Rating
<b>Produce Traceability</b>	<b>3.08</b>
<b>Produce Safety</b>	<b>2.58</b>

In final section of the questionnaire, the interview focused on the viability of the blockchain system and the technical aspects of it. The respondents were asked on their views to the development of the system. This were largely qualitative question, asking the farmers to give their views and advice, if need be on these question

#### **4.2.2.9. Would the Farmers Like to have a System that will Enhance Food Traceability and Food Safety of their Produce**

When asked whether they would like to have a system that would enhance traceability and food safety of their produce? All of the farmers said Yes, They would like to have such a system. The reasons for their answers varied from the farmers wanting to see accountability in the name of the responsible individuals in the contamination of food products being held capable; to getting more customers by virtue of providing reliable food produce from the farmer that has high standards of food handling; to some famers showing great concern to their customers by wanting the customers to get high quality food that does not affect their lives. Below are some of the answers that were received:

- i. So that I can know who exactly is to blame when it comes to unsafe food.
- ii. This will help me to boost my business and have loyal customers, since I know where the produce pass through till the last customer”
- iii. To know who exactly should be accused in case there is a problem
- iv. To ensure my customers are safe from my produce
- v. Need to know the types of chemicals used during processing
- vi. To ensure food safety because some processing bring more harm to our health
- vii. I will be happy to know my produce is safe for consumption
- viii. To reduce the amount of chemicals used for preservation which are harmful to our health
- ix. Need to know the end product is safe for consumption, that would make me happy
- x. To reduce diseases that are caused by bad food processing
- xi. To ensure that I am safe and my customers are safe too, because we are not sure what is used during processing
- xii. This will help reduce disease such as cancer that are caused by bad food processing or chemicals used during planting

#### **4.2.2.10. Medium to Access the System Via**

Most of the farmers preferred to access the system via their mobile devices, with 59% of the getting registered as having answered to this preference as illustrated in Figure 4.7. Kenya is a leading country in Africa on smartphone penetration at 91% compared to Africa 80%. .Jumia Kenya, an online shop in Kenya, reported having 70% of their traffic coming from mobile

phones (Namunwa, 2019). This is a good indication that for an application to succeed in Kenya, developers have to consider mobile application.

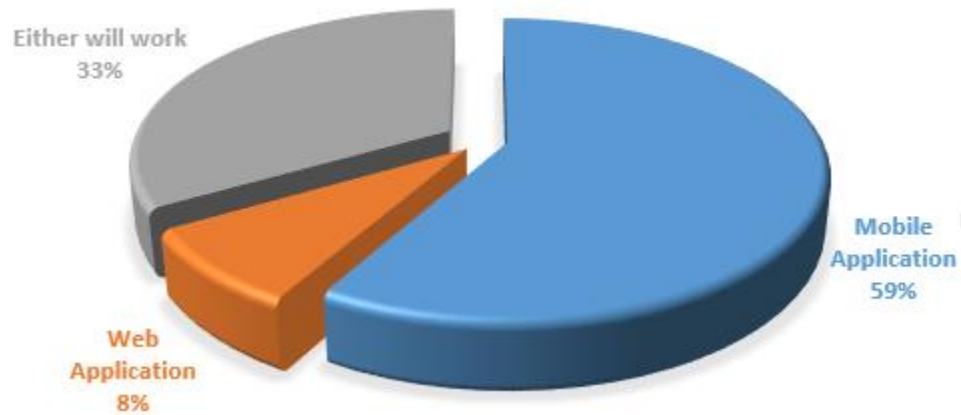

Figure 4.7 : User Preference on Access of the System

All farmers interviewed preferred the industry advised two-factor authentication in accessing the system. This is to protect the integrity of user data and the user privacy. This could be implemented by having the user receive a text message to confirm login after putting in their password. This will help protect data integrity and enhance reliability of the system.

#### 4.2.2.11. Would You Sell To Customers Directly or to Distributors

Some farmers would like to deal with the customers directly by removing the middle men. However, some farmers would like not to deal with the logistics that comes with dealing with customers directly and hence would like to use distributors. To this question 83% of the respondents would prefer to be able to sell to both the customer directly and to distributors. None of the farmers would like to sell to the distributors alone while 17% of the customers would like to sell to the customers directly as shown on Figure 4.8.

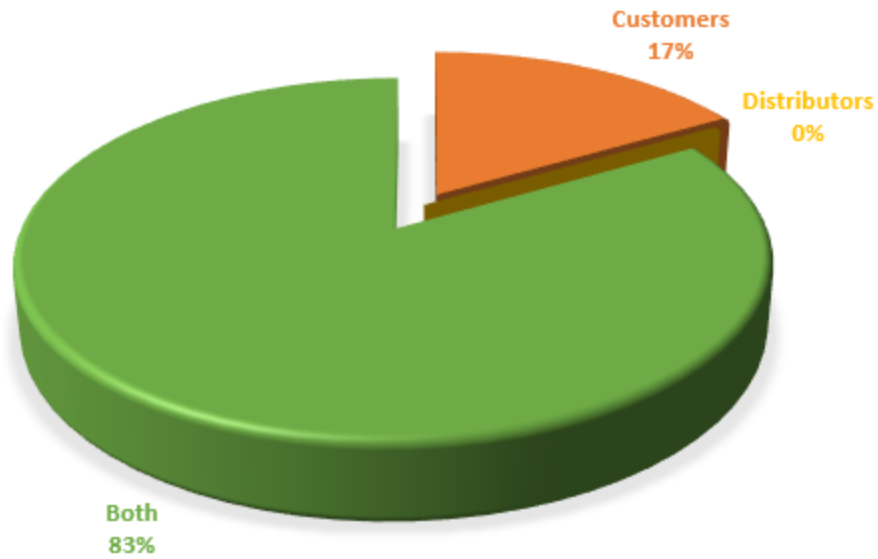

Figure 4.8 : Sale Preference for the Farmers

#### 4.2.2.12. Authentication Preference by the Farmers

83% of the farmers prefer two-factor authentication to single authentication during the implementation phase of the system. Figure 4.9 illustrates this analysis. Though many Kenyans use mobile devices to access many application, there is a general apprehensiveness when it comes accessing delicate application that have sensitive data via mobile device due to their vulnerability to hacking and cyber attacks.

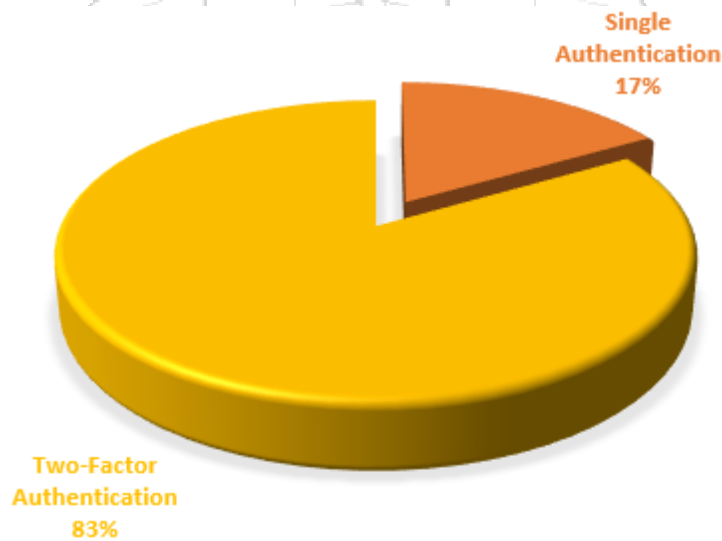

Figure 4.9 : Authentication Preference by the Farmers

#### 4.2.2.12. Whether the Farmer would like to Buy Farm Produce Directly from Producers or Wholesaler

Most of the farmers would not mind buying farm inputs directly from the manufacturers or from the wholesalers while 17 percent of farmers would like to buy directly from manufacturers.

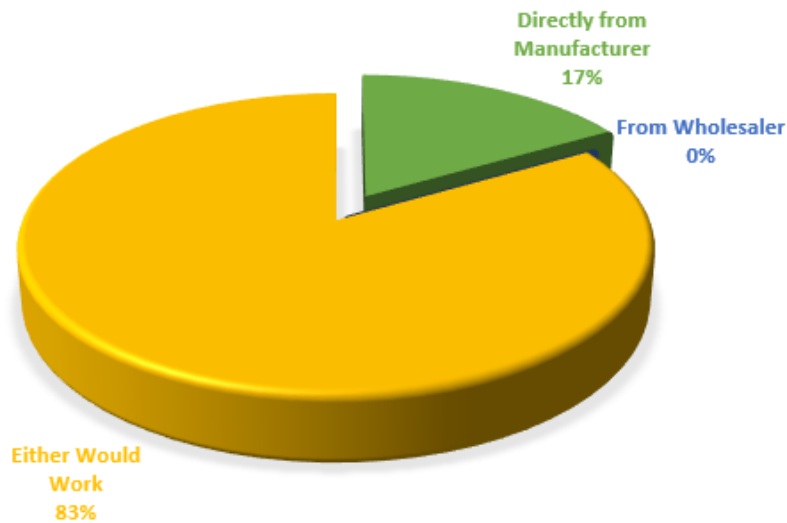

Figure 4.10 : Procurement of Farm Inputs Preference by the Farmers

#### 4.2.3. Food Processing Companies

The project was able to interview twelve officials from food processing companies. 50% of the officials were male while the other half were female in gender. Of the interviewed, 34% were in the upper management, 58 in the middle management and 8% were workers. This gave the project an arrays of different respondents that would give an interesting perspective to the questionnaires as illustrated in Figure 4.11.

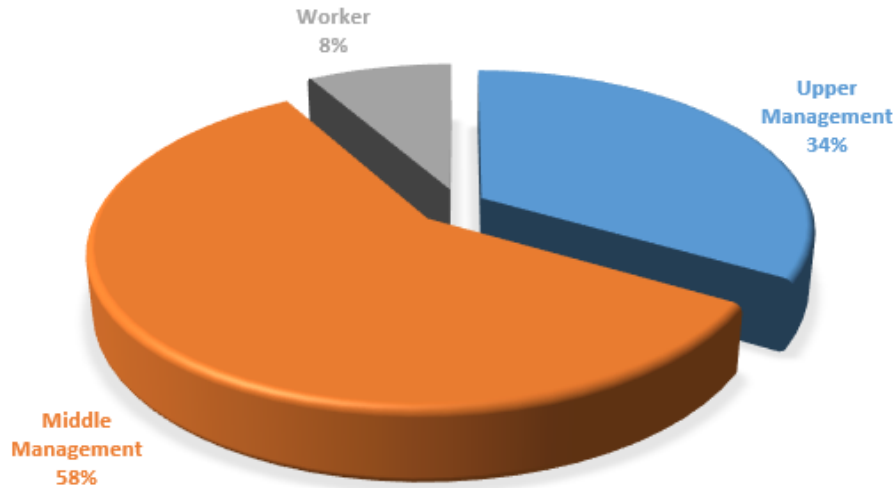

Figure 4.11 : Position of the Respondents in the Respective Companies

The education level of the interviewed had 42% as master's holders while 58% were bachelor holders as illustrated on Figure 4.12. This also gives a variant in terms of education background and the views of the respondent in question.

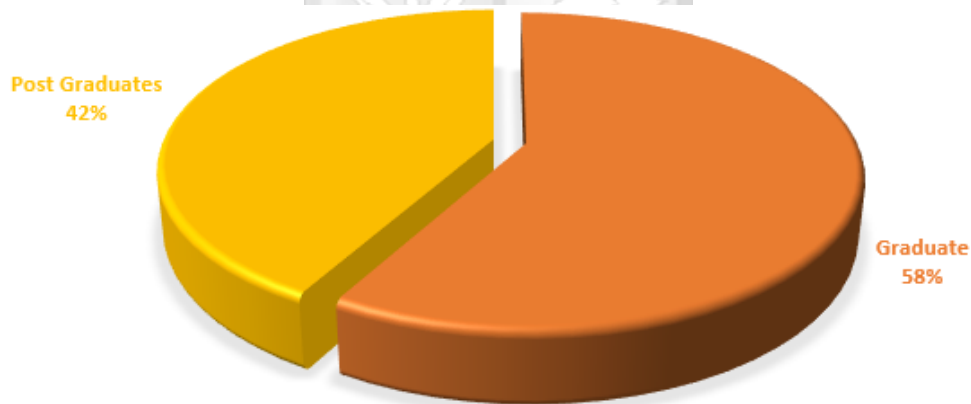

Figure 4.12 : Education Level of the Respondents

#### 4.2.3.1. Whether the Company has Ever Registered a Food Borne Crisis

When asked whether their company has ever registered a case of food borne disease, 50% of the respondents gave us an answer to the affirmative, 42% of the respondents said that they have never registered such a case while 8% of the respondents said that they were not sure. This is illustrated on the pie chart of Figure 4.13.

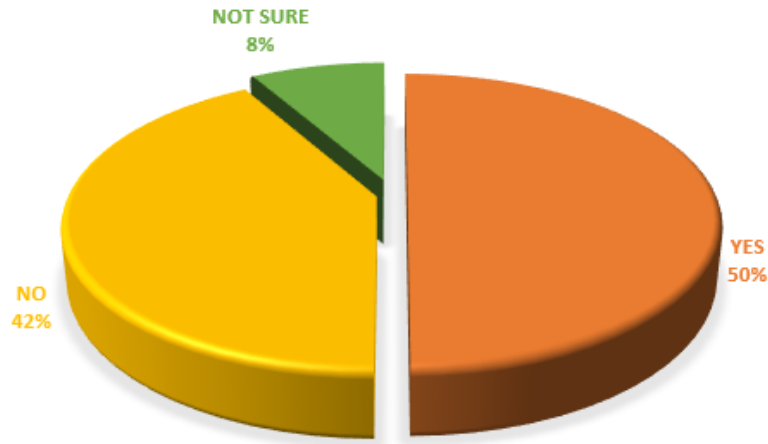

Figure 4.13 : Percentage of Companies that have Registered Food borne Cases

#### 4.2.3.2. At What Stage the Company did the Food Get Contaminated

For the 50% of the respondents that had registered Food Borne cases in their companies, 57 % of them said that the contamination took place at Food Processing stage. 29% of these respondents said that the Farm produce was already contaminated by the time they got to the company and 14% of the respondents believe that the contamination was due to the farm inputs that the farmer used in the farming process. The responses are illustrated on Figure 4.14.

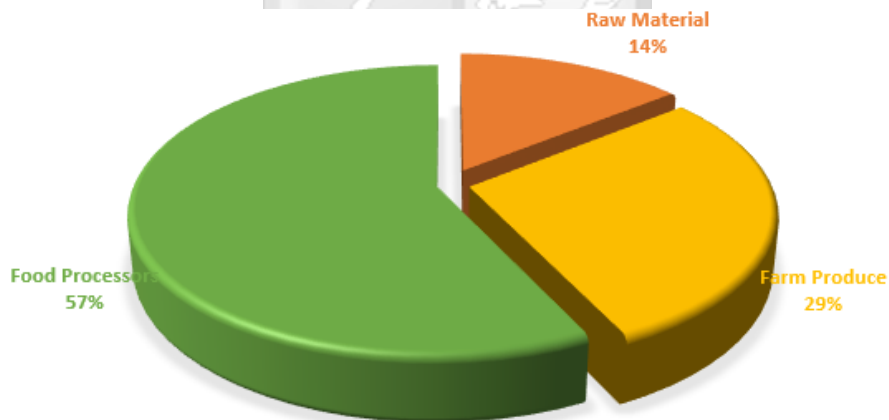

Figure 4.14 :Stage of Contamination of the Company Products

#### 4.2.3.3. Company's Action after Finding Out of the Food Borne Issue

All of the companies that had registered an issue with their products, said that they recalled their products from the market. Amazingly, none issued an alert to the public about the issue. This would go as an oversight issue with relevant offices either not aware here of what was taking place

are for one reason or the other were not able to enforce laws by making the company to go public. It therefore begs the question, on how the recall was done if at all it was done.

On the second section of the questionnaires to the company representatives focused on the approaches they use to enhance food traceability and safety.

#### 4.2.3.4. Approaches Employed by the Companies to Enhance Food Traceability and Safety

All the companies use a combination of approaches to enhance food traceability and safety. 39% of the combination use Unique Identifies (Tag and Bar Codes) and Real Tracking of Delivery Tracks. 22% of them use Distributed Ledger Technology to enhance food traceability as illustretd on Figure 4.15.

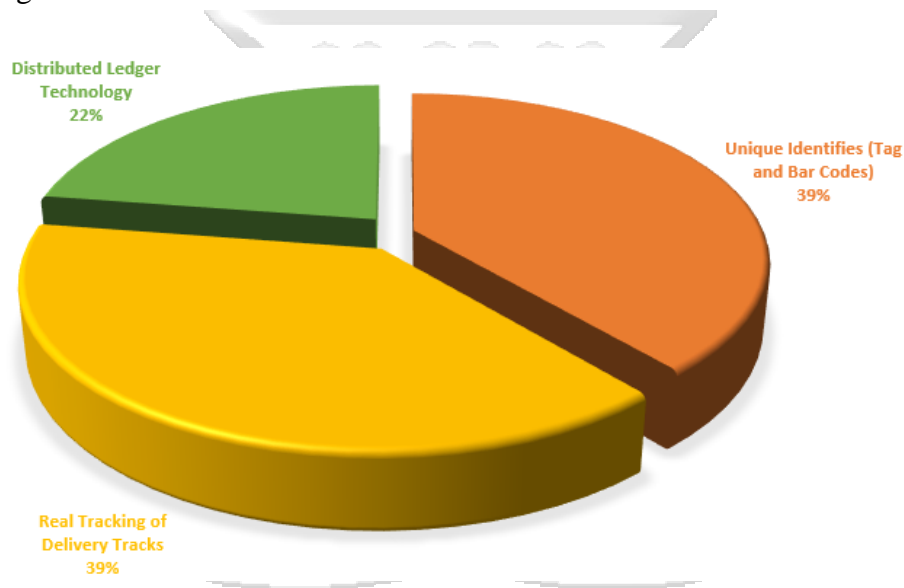

Figure 4.15 : Popularity of the Approaches by the Companies

#### 4.2.3.5. Considering the Approaches Selected Above Only, Rate the Same on the Effectiveness in Enhancing Food Traceability and Safety

Distributed Ledger technology received the highest rating though it was rated by only 58% of the companies interviewed. This shows that it is not widely used but the companies that use it acknowledge its effectiveness. This was followed by Real Tracking of Delivery Tracks at 3.33 out of the possible 5. Unique Identifies (Tag and Bar Codes), was selected by all compagnies at the rating of 3.17. The average ratings are shown on Table 4.3.

Table 4.3 : The Average Rating the Approaches on the Effectiveness to Enhance Food Traceability and Safety

Approach	Average Rating
Unique Identifies (Tag and Bar Codes)	3.17
Real Tracking of Delivery Tracks	3.33
Distributed Ledger Technology	3.57
Approach Specified	0

**4.2.3.6. Rate the Challenges You Have Experienced with Produce Traceability and Produce Safety Considering the above Approaches**

Companies have registered more challenges with product traceability than with safety. Though both rated at the small extent level, product traceability was notch higher by 0.19 in the rating as is illustrated in Table 4.4.

Table 4.4 : The Average Rating for Level of Challenges Companies have Experienced with Product Traceability and Produce Safety

Challenges	Average Rating
<b>Product Traceability</b>	<b>2.17</b>
<b>Product Safety</b>	<b>2.08</b>

The final section of the questionnaire sought the views of the companies towards the development of block chain technology system to enhance food traceability and safety. When asked if they would like to have such a system, all the respondents marked yes to question. Their explanation to their answer varied from increasing their value to assuring their customers. Below are some of the answers that were collected:

- i. To know where exactly the problem is when there is an issue
- ii. Due to current situation where most food produce bring health issues, we need to be sure so as to assure our customers that they are safe with our products.

- iii. To reduce the food safety problems that are currently on the rise
- iv. This will help us become more efficient since we will know where the problem is
- v. Help prevent food borne disease that are currently on the rise
- vi. To ensure we have the best and quality product that is safe to our customers
- vii. Traceability helps us lead our customers to a better understanding of our business process and hence win their trust with our products
- viii. This help us gain more trust from the public and customers hence more sales
- ix. To assure our customers whenever there is a problem where exactly the problem came from
- x. This help us identify and isolate the source of the problem and deliver the best quality product.
- xi. Help track the amount of chemical used during processing
- xii. This helps us respond directly to the food safety issues and help us act after knowing where the problem is. It also help us enhance the value of our products

All companies would not mind either a web platform or a mobile application. They would neither mind buying directly from the farmer or from distributor of farm produce. All companies indicated they would prefer two-factor authentication.

#### **4.2.4. Food Consumers/Customers**

The final questionnaire of the project went out to the customers or consumers of the food products. The project was able to interview 13 customers. They were randomly selected from all over Nairobi to give the questionnaire an acceptable variance. The exercise was voluntary and no customer was forced or paid to take the questionnaire.

##### **4.2.4.1. The Age Range of the Respondents**

Most of the respondents interviewed were of 40 years and above at 38%. The ages of 30 to 40 tied with the ages of 20 to 30 at 31% each as is illustrated on Figure 4.16. The project therefore found almost balance in all age groups' in terms of respondent. The respondents were from Nairobi County, residing in various parts of Nairobi; from Westlands, Donholm, Dagoretti, Buruburu, Umoja to South B.

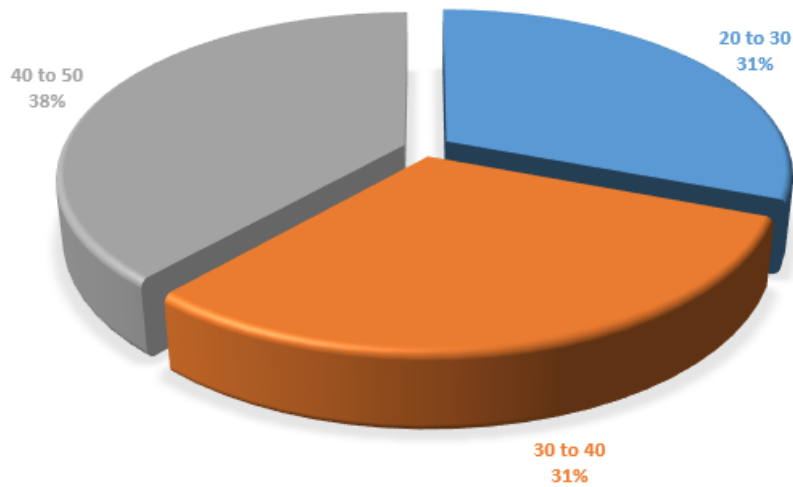

Figure 4.16 :

#### 4.2.4.2. The Gender of the Respondents

Most of the respondents were of female gender at 54%. The male respondents were 46 % of the total interviewed respondents as shown on Figure 4.17. Most of the grocery shopping in our families is done by the wives/mothers though debatable number of men are the breadwinners. It was therefore critical to get perspective of the genders.

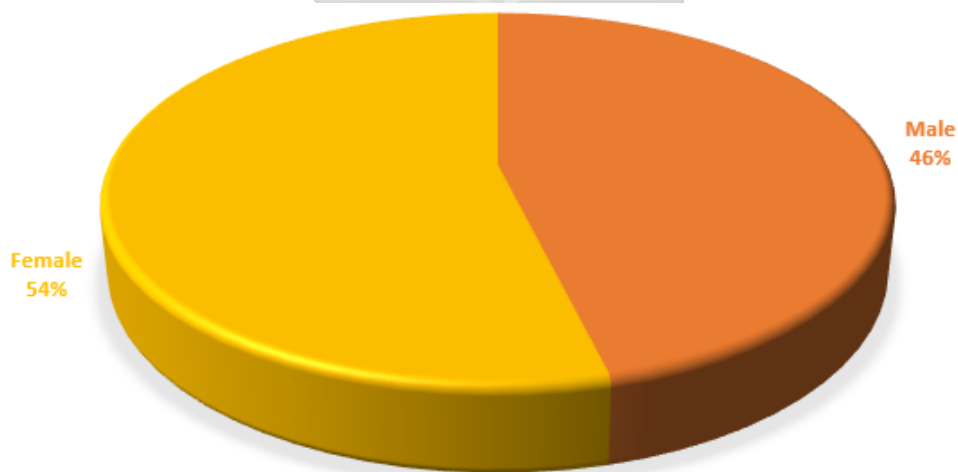

Figure 4.17 : The Gender of the Respondents

#### 4.2.4.2. The Education Level of the Respondents

Of the Interviewed respondents, none had Primary education level. Most were graduates at 62% followed by Secondary level at 23% and post graduate at 15% as illustrated in Figure 4.18. The project got an average mix of respondents in terms of education.

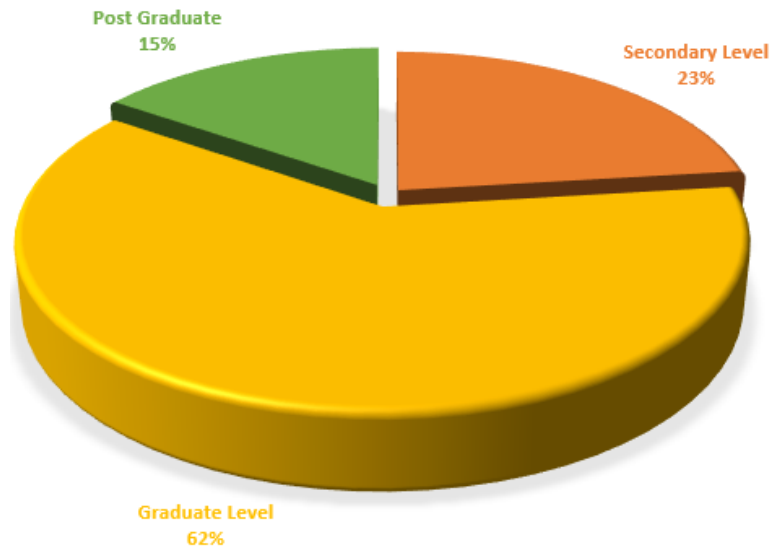

Figure 4.18 : Education Level of The Reposndents

#### 4.2.4.2. Whether the Customer have ever been Victim of a Food Borne Disease Case

69% of the respondents had experienced cases of food borne disease in their lifetime. 23% of the respondents said they had not experienced this before while 8% were unsure of whether they had experienced a case or not. The responses are illustrated on Figure 4.19. The deduction from this question was that many thought that a food borne disease have to be crisis like the mercury in sugar scandal or the poisonous maize.

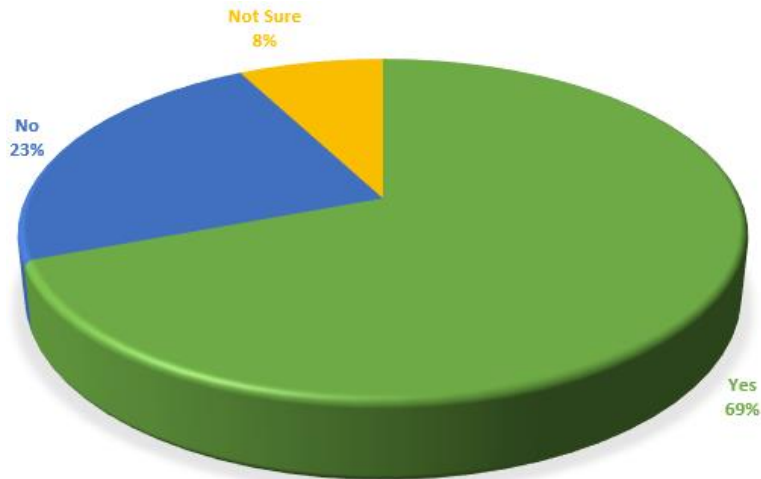

Figure 4.19 : Percentage of the Respondents who have Experienced Case of Food Borne Disease

#### 4.2.4.2. Whether the Customer found out at What Stage the Food Contamination Took Place

The question got a no answer of 21% pointing to either the respondents not understanding the question or they do not know at what stage the food might have gotten contaminated. A larger majority at 42% believed that the contamination took place during the transit of the food while 37% of the respondents believed the contamination took place at the food processing stage. Respondents did not believe that the contamination happened because of the raw material used in the farming process such the pesticides used or manure used. The contamination of the farm produce also got 0%. This is illustrated o Figure 4.20.

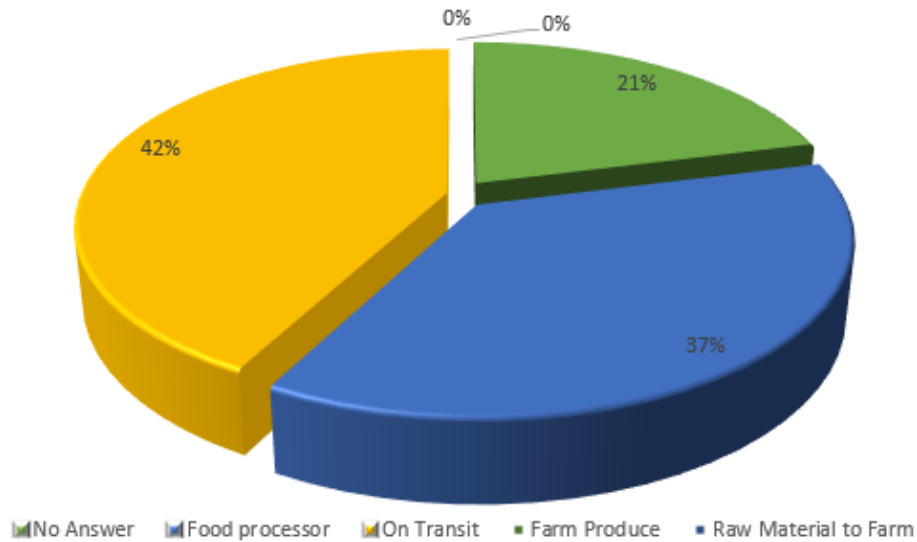

Figure 4.20 : The Stage at which the Respondents Believe the Contamination took Place

The next section of the customer's questionnaire focussed on the strategies in the transparency, accountability and distribution in the food supply chain. The questions in this section to find out if the customers had witnessed farmers employing the strategies mentioned in enhancing transparency, accountability and distribution in food supply chain. Star rating was used in the preceding question to get to know, to what extent the strategy was employed.

#### 4.2.4.3. Whether Farmers Use Mobile Service Delivery to Market and Check Pricing Information

The question got an average rating of 2.3 which shows that customers have seen or witnessed farmers employ this strategy only to a small extent as shown on Figure 4.21. Give that the research took place in Nairobi, the result might be misleading s some of the respondents might have never interacted with farmers.

5★	0
4★	0
3★	5
2★	7
1★	1
Average rating	2.307692
Total votes	13

Figure 4.21 : The Average Rating for the Level of Embracing of use of Mobile Service Delivery to Market and Check Pricing Information

#### 4.2.4.4. Whether Farmers Use Tagging of the Produce (RFID/Bar Code) For Tracking Information

Almost similar to previous question the question go an average of 2.2 from the customers, indicating the customers had not witnessed farmers using this strategies. This could mean many things from; farmers not using the technique to; customers not knowing the technique hence they can't identify it when they see it. The rating is illustrated on Figure 4.22.

5★	0
4★	2
3★	3
2★	4
1★	4
Average rating	2.23077
Total votes	13

Figure 4.22 : The Average Rating for Level of Use of Tagging of the Produce (RFID/bar code) by Farmers for Tracking Information

**4.2.4.5. Whether Farmers Have a System to Capture the Source of Manure and Water Usage**

Customers gave the question a rating of 2.46 as is shown on Figure 4.23, which is a better rating than the above two questions so far. This indicates that the customers believe that farmers know the source of the farm inputs such as manure/fertilizer or the pesticides.

5★	0
4★	2
3★	3
2★	7
1★	1
Average rating	2.46154
Total votes	13

Figure 4.23 : The Average Rating for Level of Use of System to Capture the Source of Manure and Water Usage

**4.2.4.6. Whether Farmers Have a System to Capture the Details of the Wholesaler Who Collects Their Produce**

The customers believe that an average number of farmers have records of the wholesalers they sell their farm produce to going by the rating the customers gave the question of 2.8 out of 5 as is illustrated in Figure 4.24. This is a higher rating than the rating by the farmers on the same question. This may mean that farmers give the impression that they know who they sell their produce to or the customers/public assume that farmers know their wholesalers.

5★	0
4★	2
3★	7
2★	4
1★	0
Average rating	2.846154
Total votes	13

Figure 4.24 : The Average Rating for Level of Use of System to Capture the Details of the Wholesaler Who Collects Farmers Produce

**4.2.4.7. Whether Farmers have Strategies to Control Foodborne Pathogens their Your Farm**

The customers gave the question an average rating of 2.6 as illustrated on Figure 4.25. This could go to mean that while they believed that some farmers have strategies in place, some did not have any strategies to control foodborne pathogens in place.

5★	0
4★	4
3★	2
2★	5
1★	2
Average rating	2.615385
Total votes	13

Figure 4.25 : Average Rating on the whether the Farmers have Strategies to Control Foodborne Pathogens

The third section of the customer questionnaire focussed on the approaches that are used by the farmers to enhance food traceability and safety.

**4.2.4.8. What Approaches the Farmer Uses to ensure their Produce are Traceable and Safe**

All customers are familiar with produce inspection approach but not the other two; Produce Audit or Produce Recall and Enforcement. This could mean that they have never had an experience where produce is recalled from the market by the enforcing agency of the government.

**4.2.4.9. Considering the Approaches Selected Above Only, Rate the Same on the Effectiveness in Enhancing Food Traceability and Safety**

Produce inspection was the only approach that customers were familiar with as discussed on section 4.2.4.8. Customers went ahead and gave it a rating of 2.62 on its effectiveness to enhance food traceability and safety. This is depicted on Table 4.5.

Table 4.5 : Showing the Average Rating of the Effectiveness of Approaches Selected by Farmers

Approach	Average Rating
<b>Produce Inspection</b>	<b>2.62</b>
<b>Produce Audit</b>	<b>0</b>
<b>Produce Recall and Enforcement</b>	<b>0</b>
<b>Approach Specified</b>	<b>0</b>

**4.2.4.10. Rate the Challenges the Farmers will Experience with Produce Traceability and Produce Safety Considering the Above.**

Customers do not think that produce inspection will help much when it comes to produce traceability and produce safety. Produce Safety got slightly higher rating of 3.76 meaning it will be more challenging to farmers than food traceability. The average ratings are shown on Table 4.6.

Table 4.6 : The Average Rating for Level of Challenges Farmers have Experienced with Produce Traceability and Produce Safety

Challenges	Average Rating
<b>Produce Traceability</b>	<b>3.46</b>
<b>Produce Safety</b>	<b>3.76</b>

The final section of the customer questionnaire sought the views of the customers on the development of block chain technology driven system to enhance food traceability and safety.

When asked on whether they would mind having a system that enhance traceability and food safety of their food from farm to fork, all customers answered to the affirmative. The reason given for the answer mainly focussed on the health concerns given the recent sprout of food borne diseases on the media. Some of the answers are listed below:

- i. To know the types of chemicals used when the farmer is planting
- ii. To reduce the bad food in the market and even chemicals used which are harmful to our health
- iii. To be safe on the type of food I take
- iv. This will help reduce diseases that re now infecting people
- v. To be sure of what we are eating because as per now we are not sure of the sources
- vi. To know the organic content used during the process
- vii. To know the shelf life of the product
- viii. To reduce the different types of diseases that are caused by the bad food processing.
- ix. This will enable us to know the source of food unlike now we are sure where the food comes from, we cannot trust what the seller says
- x. Due to health issues that we are facing currently, it is advisable to know the food safety, because some food have to pass through processing and chemicals are put to add sweetness.
- xi. To reduce the foodborne diseases that are currently very high
- xii. To reduce the rate of increase of some diseases that we get due to food processing

xiii. We currently have frequent food poisoning, its al; over the news. So we need to know how safe is the food we eat by knowing the path it takes

#### 4.2.4.11. Medium to Access the System Via

Most of the customers would like to access the system via their mobile handsets at 50% of the responses that the project received. 43% of the respondents do not mind which platform the system will run on as long as they can get the information they need. Only 7% wanted the system to be specifically accessible via the web as shown on Figure 4.26.

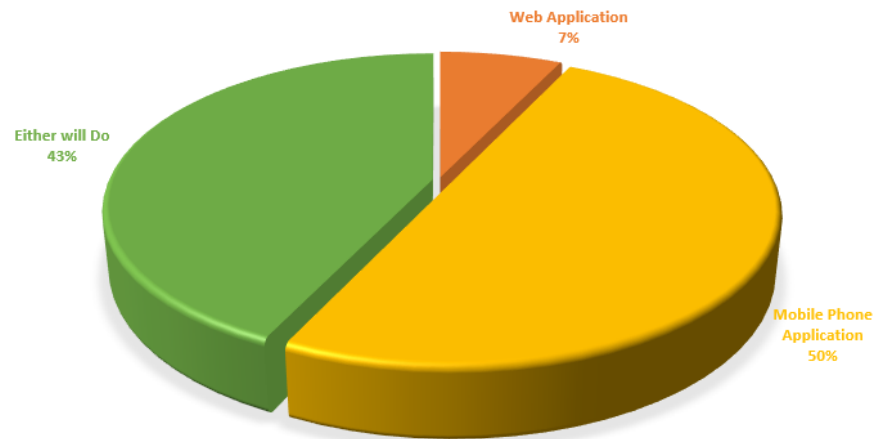

Figure 4.26 : User Preference on Access of the System

#### 4.2.4.12. Would You Buy Directly from the Farmers or Would You Buy from Distributors

Most customers would like to buy farm produce directly from farmers. A 77% is a huge number which goes to show some level of mistrust of distributors and manufacturing industry by the customers. 23% would not mind buying from either the distributor or farmer. None of the customers would like to buy only from distributor as illustrated on Figure 4.27.

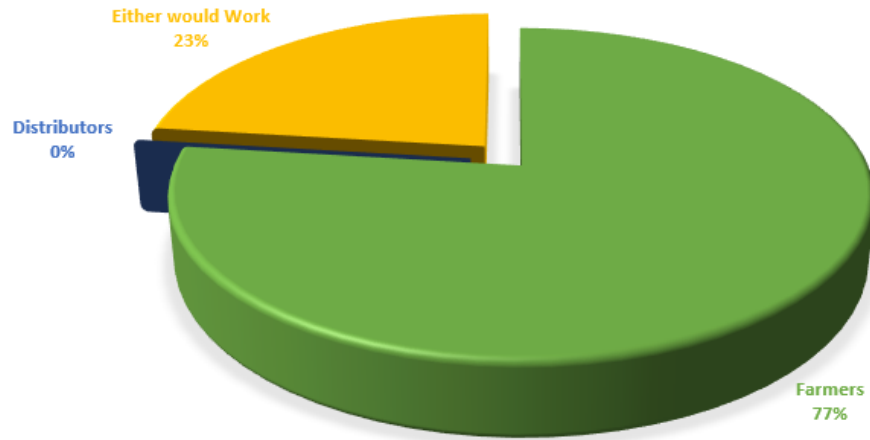

Figure 4.27 : Commerce Preference of Customers

#### 4.2.4.13. Authentication Preference by the Customers

Most customers would prefer single authentication at 69% of the feedback received. 31% of the customers would prefer two-factor authentication as shown on the pie chart of Figure 4.28.

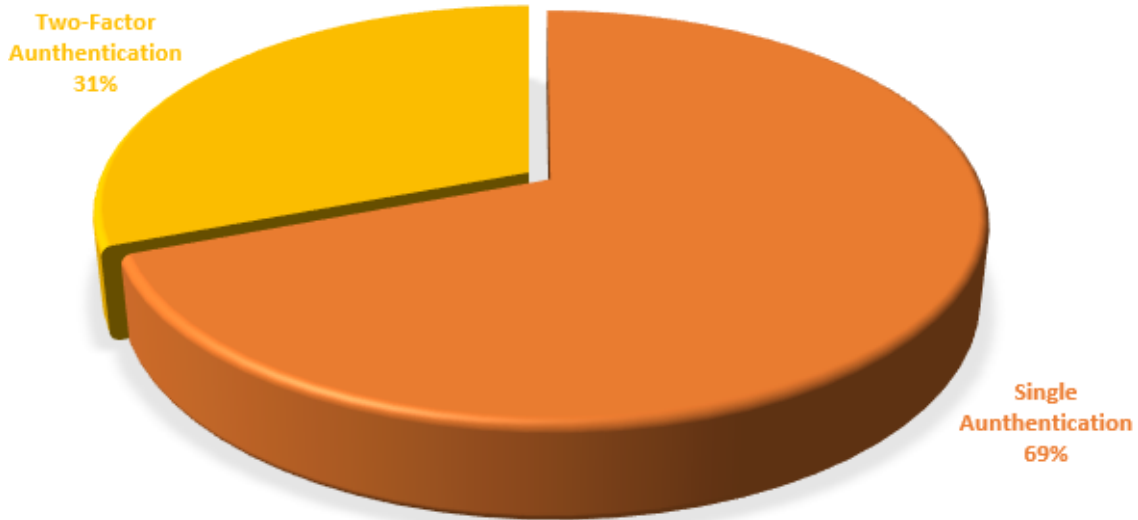

Figure 4.28 : Authentication Preference by the Customers

#### 4.2.5 Summary of Data Analysis

The farmer's main concern was accountability in the food chain. A food on the table should be able to be traced back to the source and all processes and chemicals added to it be determined. This will not only assure them of their customer safety but also get them more customers by virtue of the customer trusting that they use good practice to produce safe products for

consumption. They would also like to see accountability where guilty parties are held accountable and information in the system can stand a test in a court of law.

Considering that the food processing themselves believe that a large number of contamination at 57% takes place at the company, it's important that the food chain be traceable through the system to absolves the farmer of any blame. Though, companies note that 29% of the contamination happened before the produce reached the company, it may be hard to establish at what stage the contamination took place as exactly, because the produce may have been contaminated on transit and not necessary from the farm. But this raises the question of, if the food was contaminated in the first place why would the company proceed and process it anyway. This brings into the question the integrity of the company.

All companies recall their products when a contamination has been noted. The system should therefore be able to give the food processors an option to recall their products, either from the supplier or from consumers directly. All food processors use a combination of Unique Identifies (Tag and Bar Codes), Real Tracking of Delivery Tracks and Distributed Ledger Technology in enhancing food traceability. The system should be able to give the food processor options to enter various variables such bar code number of a product.

Food processors, believe the system will enable them gain the confidence of the public; be able to respond appropriately and timely when there is an issue. They believe with proper implementation of the system, they will be able to isolate the problem and thus reduce the damage that may have taken place.

Most food consumers have experience food poisoning/food borne disease in their lifetime. This could be the reason why most customers would like to have the application developed that help them trace food from farm to fork. The reasons raised for the support of the system were mainly on health concerns. Most of the consumers would like to access the platform through their handsets were it to be developed. They would like the system to enable them buy directly from farmer's and hence do away with the middle men. Preference on the type of authentication system was split almost in the middle by customers.

#### **4.2.6 Data Analysis Discussions**

The mobile application should allow the customers to buy directly from the farmers and also from the wholesalers. The farmers should be able to buy farm input from the manufacturers directly and also from the wholesalers/retailers.

The customer should be able to launch a concern where they think there might be foodborne issue. The concern will only be visible to the government agency and to the super administrator. This to avoid creating panic and hence the situation getting difficult to manage. If the concerns are true the government agency will contact the company so that they can recall the products.

The system should allow the farmer to be able to black list a company from buying their product, should they feel the company contaminates their produce and passes the blame to the farmer or in case they do not trust the company process. The system should be able to give the company an option to note whether the stock of produce received from farmer “A” had been contaminated. A farmer will be flagged every time they get contamination mark from a company. The flags can be used by the government agency to visit the farm and certify his processes and farm inputs.

The system should be able to allow the companies to recall a product from the market. This will add a flag tied to a date of the recall to help the approvers know that the company had ones had a product issue. The flagging should be done without the farmer or the company knowledge. Only the government agency and the super administrator will be able to see the flags

### **4.3. Requirements Analysis**

The project main object is to develop a system that will allow farmers, companies and customers to trace food produce right to the source-that the farm. To be able to achieve this, the system must have very clear and well spelled out system requirement compiled from the user surveys discussed in section 4.2.2 to 4.2.6 of this work.

#### **4.3.1. Functional Requirements**

##### **Mobile Application**

Most of the users preferred accessing the platform via the mobile devices. The system therefor needs to be developed for mobile handsets. Handsets run on different operating systems and on different screen sizes. All this has to be taken into consideration when building the system.

### **Choice of Authentication**

The preference of whether to have single authentication or two-factor authentication was split almost equally. The system therefor should be able to give the use the options to choose whether they will use single or two-factor authentication.

### **Bar Code Reader**

The farmers and companies should be able to bar code the produce or products for easier tracing by the customers or wholesalers. The system should have a bar code reader functionality that read a code and brings out information on the product or the produce

### **Location Based**

The system should be able to use geospatial technology to locate the area of the users and thus bring forth suggestion of farmers and companies that are nearer to them. This would help the customers to buy directly from the farmers.

### **Rating and Flagging System**

On a successful transaction, the user will be required to rate the farmer of the company. The higher the rating the higher the level of the farmer/company when a search is made for in the system for a produce or product.

### **Blacklisting**

A company can suggest that a farmer whose produce continuously have contamination to be banned by government agency. This can also be done by the farmer if they feel the company is contaminating the produce and claiming it's the farmer that is responsible. However, it will be up to the government agency to actual effect the ban on the farmer or company after investigations.

### **4.3.2. Non-functional Requirements**

#### **Health Notification**

The system should be able to give users notification on issues of foodborne diseases across the world. This would allow the user to be aware of what is happening across the planet on matters of food and health.

#### **Intuitive**

The mobile application will be used by customers, farmers and companies as well as government representatives. Across this varied user spectrum, many will not be technology savvy and hence the system needs to be as user friendly and intuitive as possible.

#### **Records Repository Publicly Available**

Any case of foodborne disease that has been registered in this system should be accessed in printable format that can be accessed by the general public. The documents should be digitally signed by the respective government agency in charge and be able to be used in court of law.

### **4.4. System Design**

The project main goal is to develop a mobile application that will be accessed via mobile devices to access information on agricultural produce right from the time of planting; to transit on the way to warehouse; to processing at the factory facilities and finally to the customer. The mobile application will be developed using Ionic Framework v3 which will support the deployment of the application for Android platform devices as well as those running on iOS.

The administration phase for the government agency and for the super administrator will have a web interface where they will be able to login and perform actions such:

- i. Certify companies and farmers
- ii. Certify Cases hence generate documents for the public
- iii. Validation process of the bloc chain
- iv. Black list user following a request/concern or after receiving a lot of negative flags

#### 4.4.1 System Architecture

The system will be hosted on a custom server on the cloud with PHP and MySQL backend that connects to the block chain. Cloud hosting is preferred for its ease of scalability pay for what you use business model. Figure 4.29 shows the system architecture of the application. However this projects scope focusses more on the crop efficiency section as illustrated on the Figure 4.29



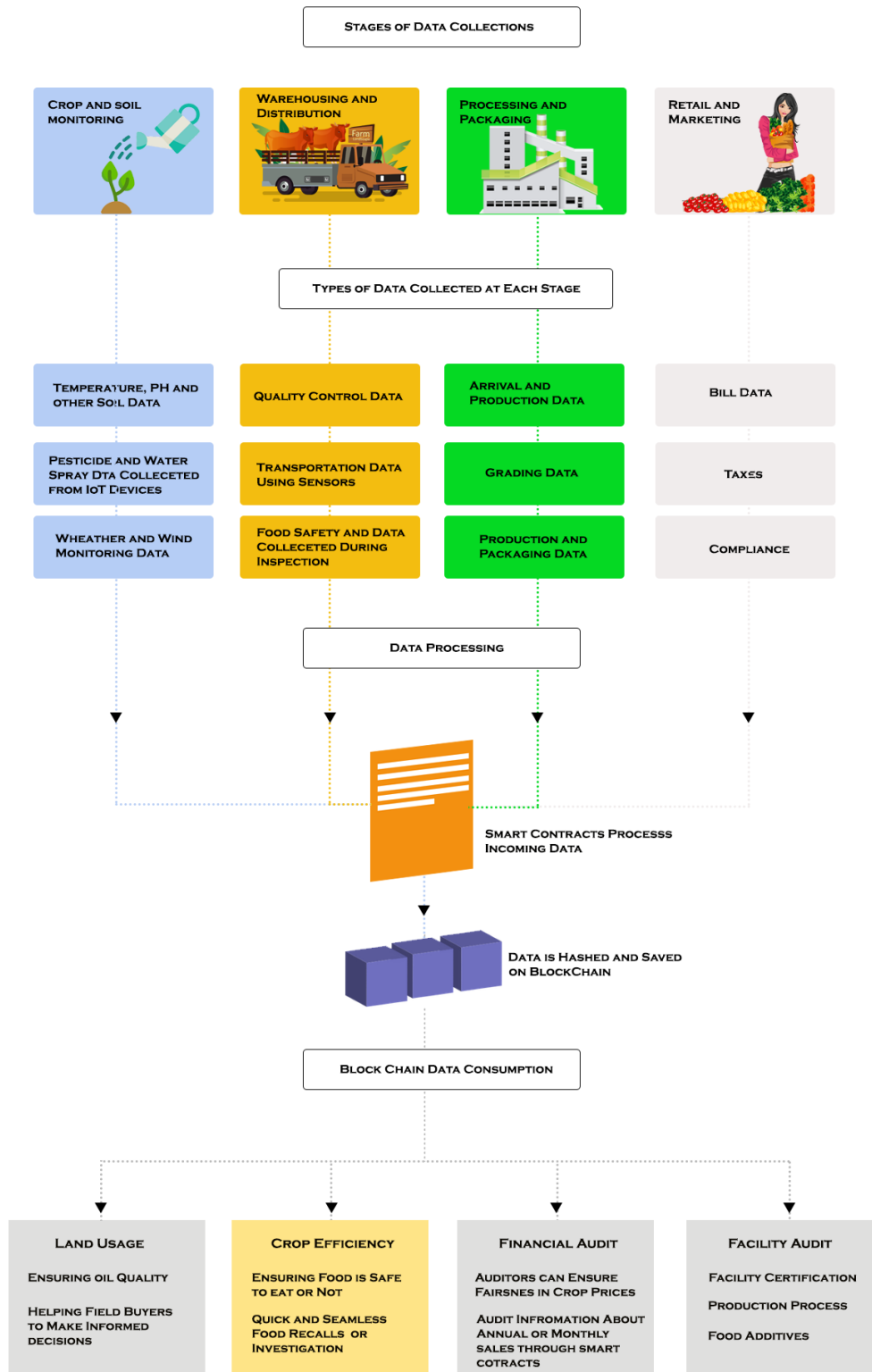

Figure 4.29 : System Architecture of Block Chain System to Enhance Food Traceability and Safety:

#### 4.4.2 Context Diagram

Figure 4.30 depicts the context diagram of the mobile application where four main stakeholders of the system interact with it in various ways. The four main stakeholder of the system are depicted in the context diagram and the processes involved.

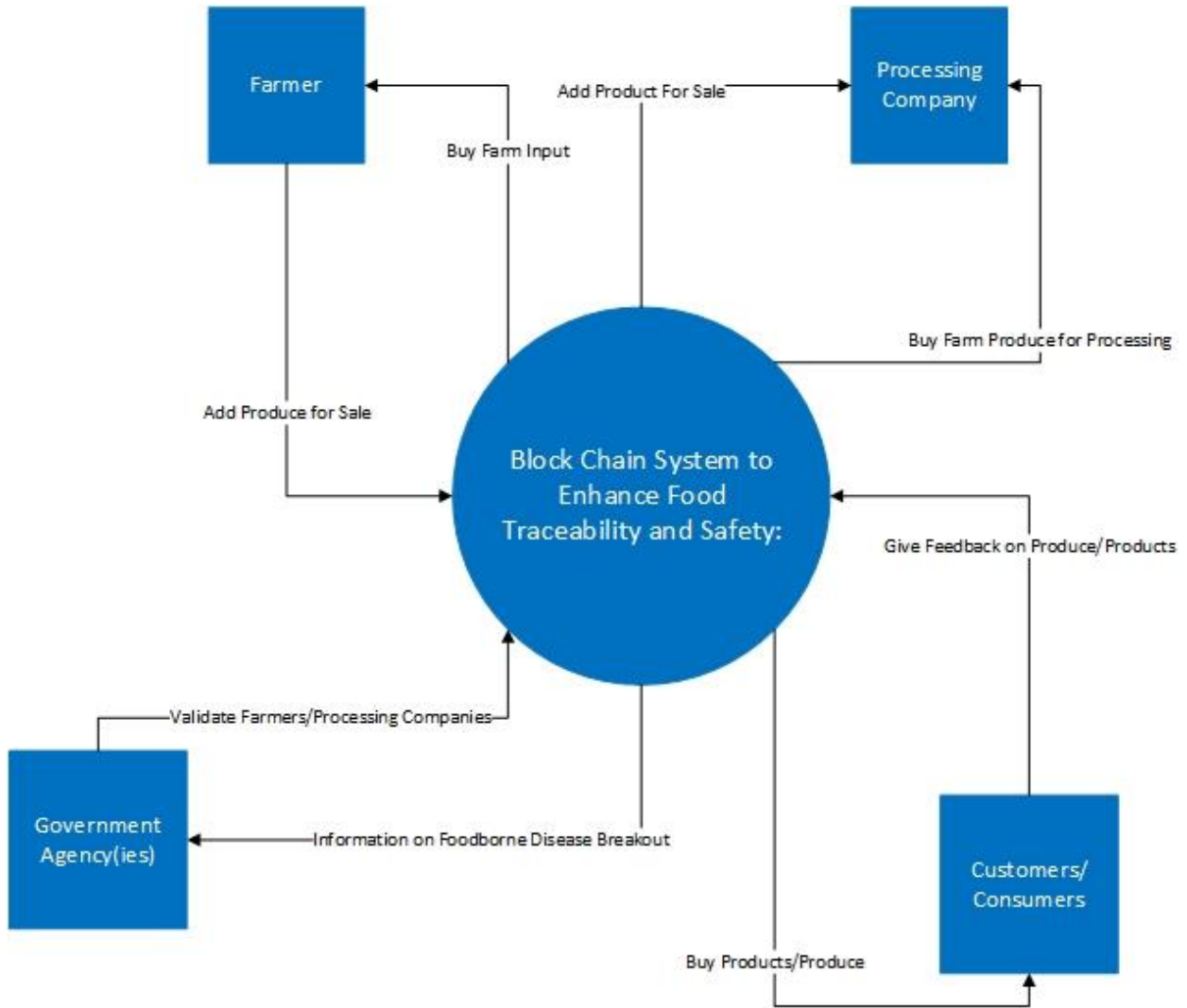

Figure 4.30 : Context Diagram of the Block Chain System to Enhance Food Traceability and Safety:

### 4.4.3 Use Case Diagram

Table 4.7 gives us the use-case main success story. Figure 4.31 shows the use case diagram for the system. The use case has the customer, farmer and the company as the Primary actors; and Mobile Money Transfer and Government as the offstage actors.



Table 4.7 : Use Case Main Success Story

ACTOR ACTIONS	SYSTEM RESPONSE
1. Use case begins when a customer/consumer registers to the system. The mobile application ones installed in the user device saves the authentication details of the user	
	2. System save the user data in the database with passwords hushed.
3. The customer searches for a product or produce that they would like to buy.	
	4. The system locates the nearest farmer or company/retailer that is nearest to the customer, selling the produce/product that the customer wants.
5. The customer goes to information details of the produce/product to trace it back to the source 6. The customer checks the rating of the farmer/company to see if they have history of foodborne diseases in their products 7. If satisfied, the customer places an order.	
	8. The systems send notification to the farmer or the

	company/retailer of the order
9. The farmer or company/retailer acknowledges the order by accepting it	
	10. The system generates an invoices that is sent to the customers email. 11. A notification about the invoice is sent to the customers mobile applications
12. The customer makes payment via mobile money transfer	
	13. A notification of payment is sent to the farmer or company/retailer about the payment
14. The farmer or company delivers the produce or the product	

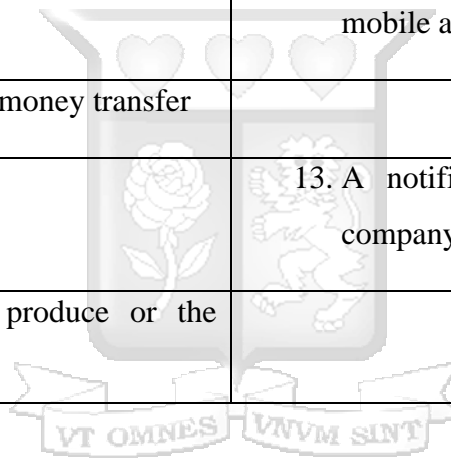

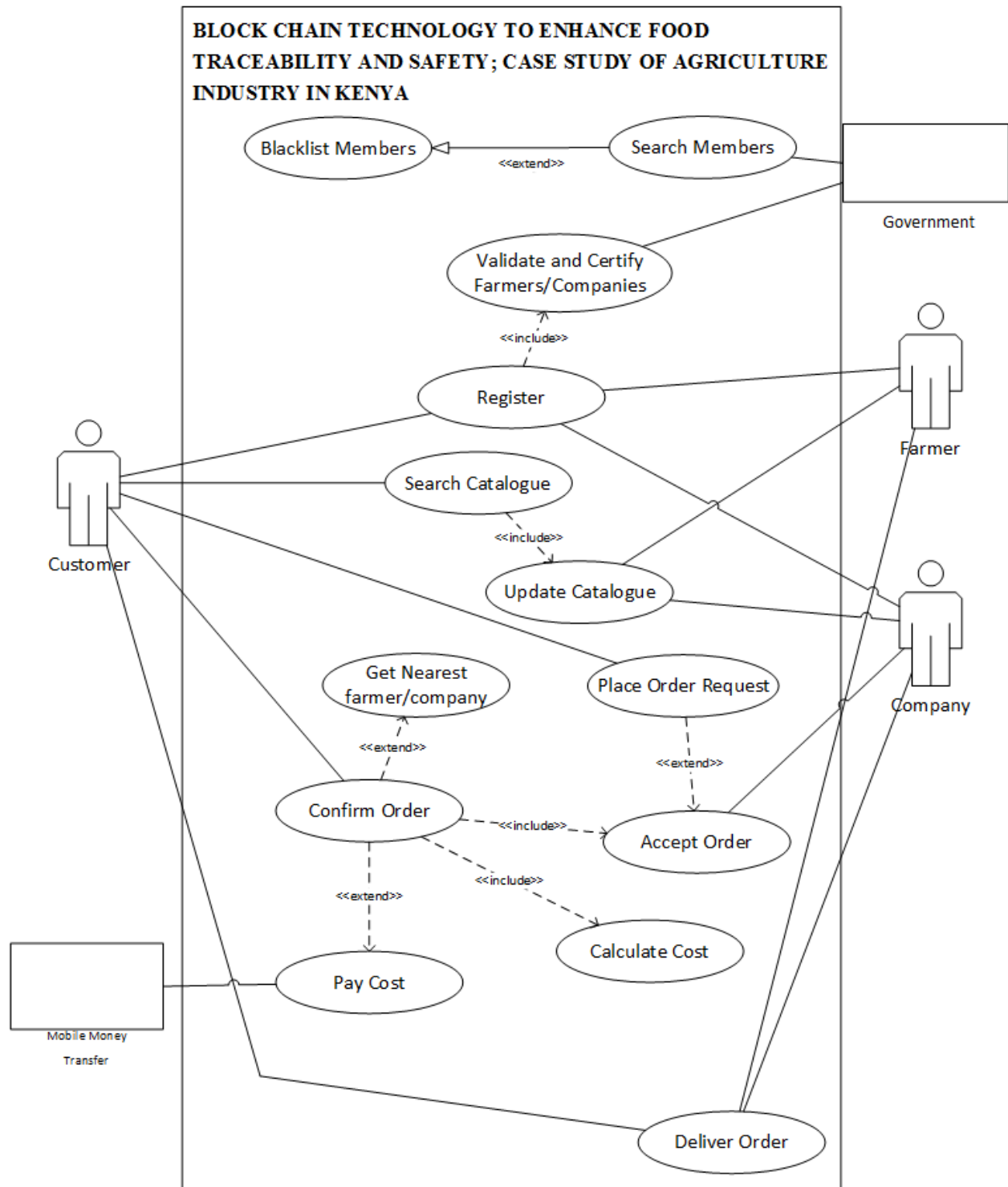

Figure 4.31 : Use Case Diagram

#### 4.4.4 Sequence Diagram

Figure 4.32 illustrates the various actors and the sequences of various functions that are invoked in the system.

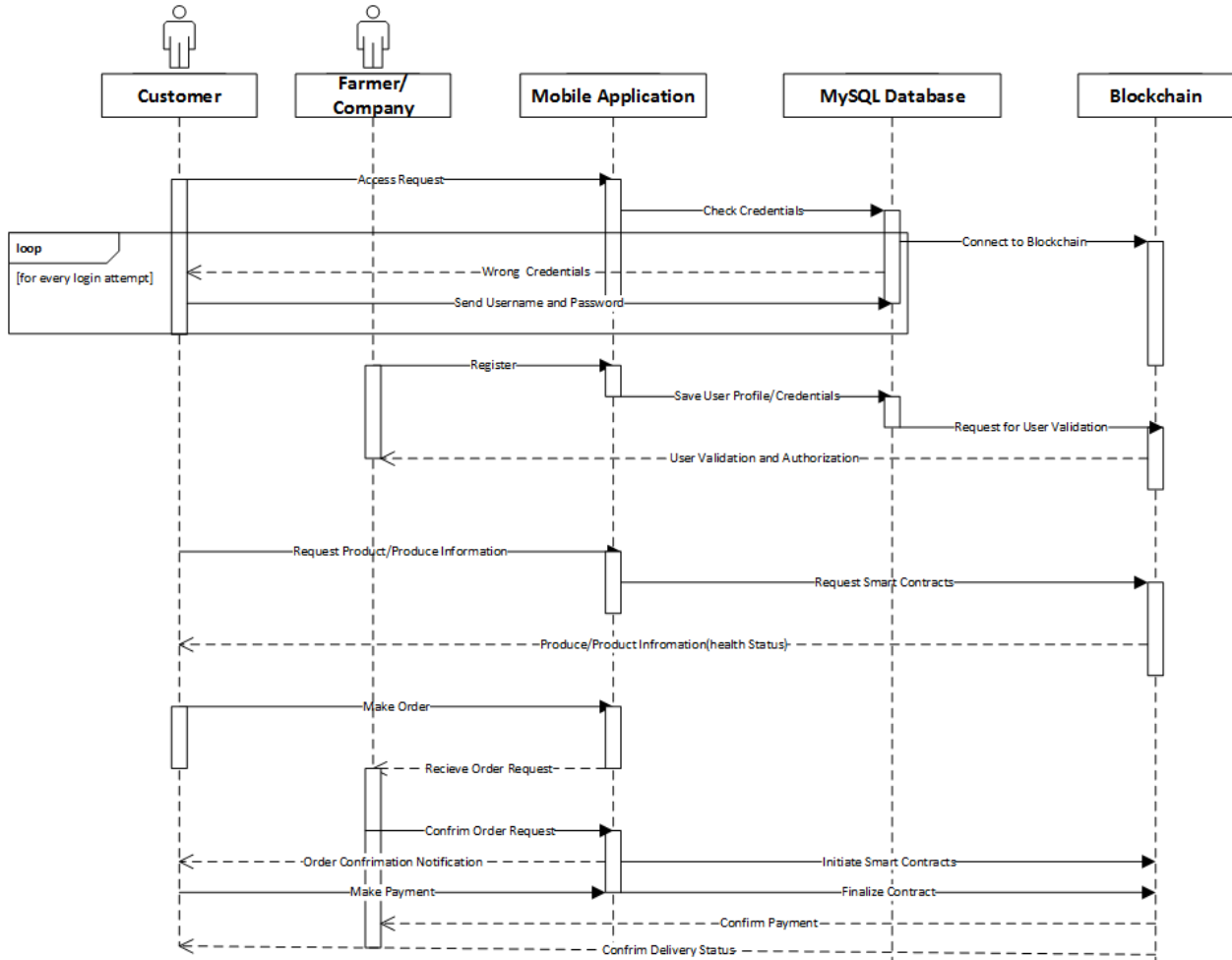

Figure 4.32 : Sequence Diagram of the System

#### 4.4.5 Data Flow Diagram

Figure 4.33 depicts the projects data flow diagram. This data flow illustrate the interaction between the main processes of the system included but not limited to registration, Login, request of order, acceptance of order, update of catalogue and making of payment. This interactions calls for various instances of datasets such as user credentials, user category, order, products among others.

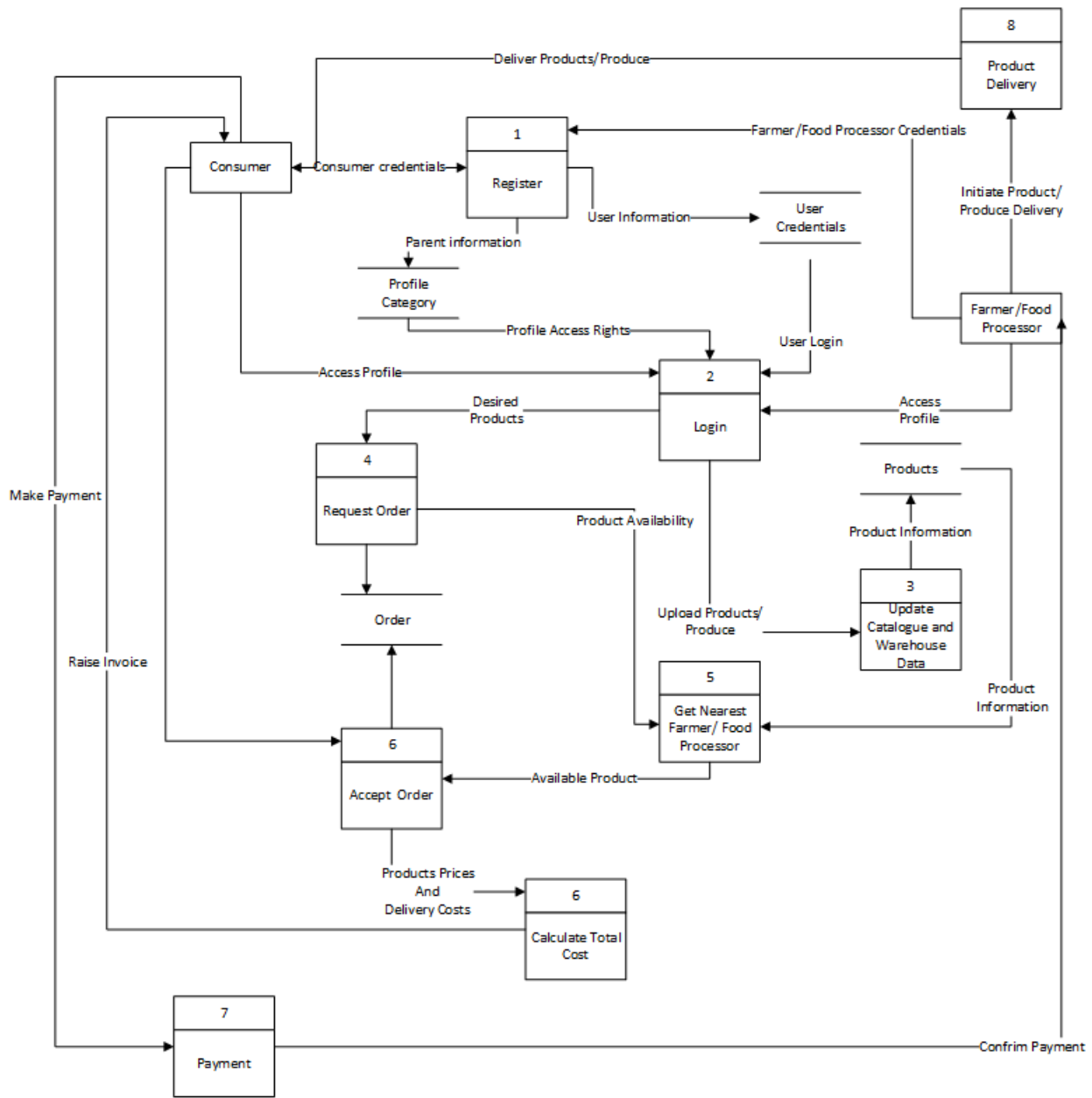

Figure 4.33 : Data Flow Diagram of the System

#### 4.4.6 Entity Relationship Diagram

Figure 4.34 illustrates Entity Relationship Diagram of the Block Chain Technology to Enhance Food Traceability and Safety; Case Study of Agriculture Industry in Kenya The main entities are farmer, farm produce, order, product, user, food processor and profile category just to mention but a few.

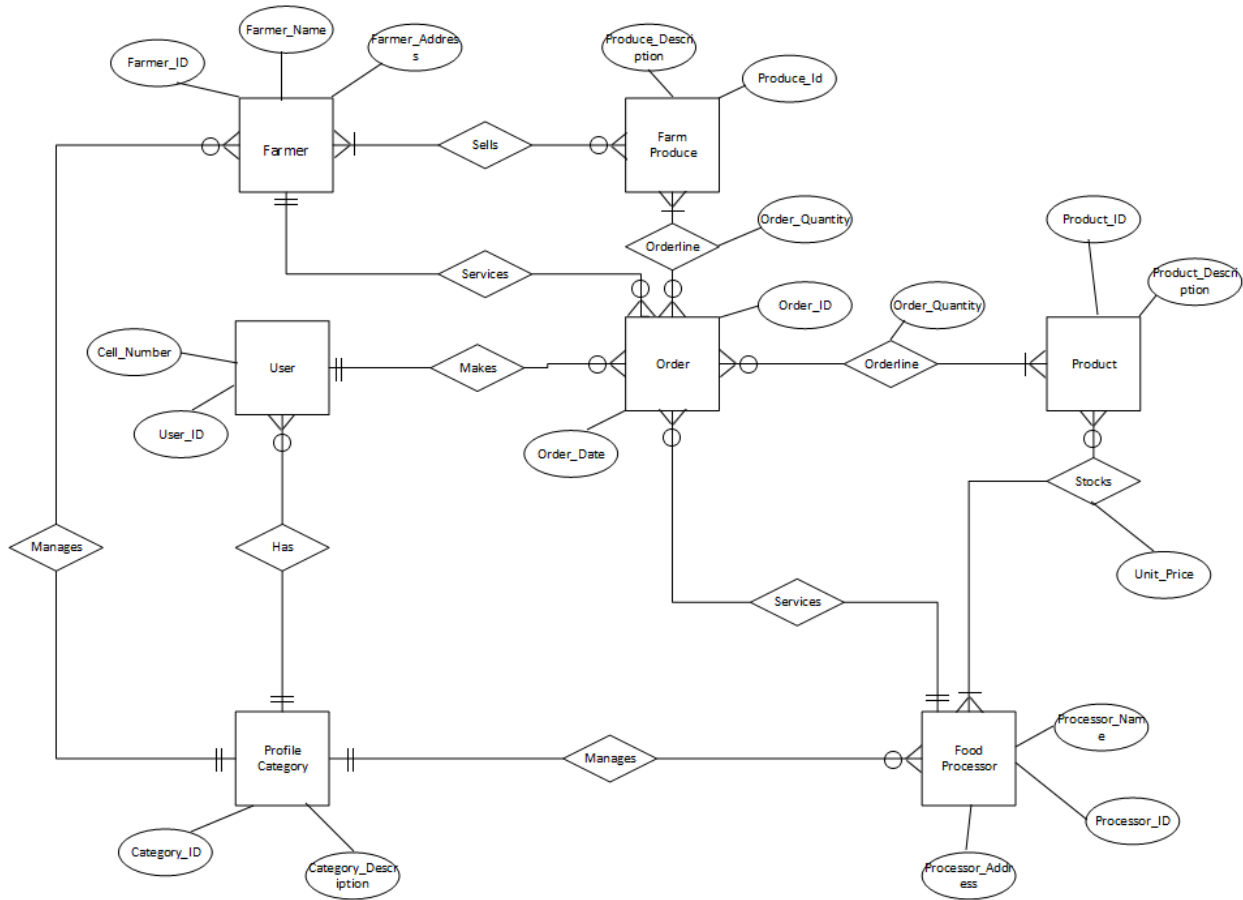

Figure 4.34 : Entity Relationship Diagram of the System

#### 4.4.7 Database

Block chain mobile application that will enhance food traceability and safety will run on two databases. The application will use MySQL to store data that needs verification such as user names and user passwords. Any data that needs to be consulted by the system will be saved in this database. MySQL being a Structured Query Language database enables websites and system that interact with it in real time.

The blockchain system will employ Ethereum smart contracts to store the final data. As a distributed computer, Ethereum has each node in the network execute bytecode called smart contracts and then store the resulting state in a blockchain. The decentralized computing platform of Ethereum enables smart contracts to automatically execute according to their code.

## Chapter 5 : System Implementation and Testing

### 5.1 Introduction

Project objectives discussed in chapter one and further enforced by the data analysis in chapter four gave the project direction on the development of Block Chain Technology to Enhance Food Traceability and Safety; Case Study of Agriculture Industry in Kenya. The project saw utilization of various platform, database types and languages. The challenging aspects of the project was separating data streams into those that are saved permanently in the block chain from the ones that need to change frequently like usernames and passwords.

### 5.2 System Implementation

#### 5.2.1 Application Hardware Requirements

##### 5.2.1.1 Server Specifications

The server hosting the Food Traceability and Safety System runs Ubuntu 18.04 LTS, on a 1 GB Nanode with 1 CPU of 25GB Storage and 1GB RAM. The service is provided by Linode cloud hosting services. The server is highly customizable with the developer having the freedom of choice when it comes to the language version and the database type to run.

##### 5.2.1.2 Mobile Application

The mobile application is compiled to run on Android version 4.4(kitkat) and above.

#### 5.2.2 Application Software Requirements

##### 5.2.2.1 Framework

Laravel framework was utilized in the development of the backend ad web system. The framework encourages code reuses because it is fully object oriented and highly modularized. Laravel framework is fully compatible with the PHP composer package manager and this makes using code written by other developers easier and safer

### **5.2.2.2 Language**

The project chose the most popular language by developers in building websites. It was used in development of the backend and the web interfaces. PHP 7.3 was chosen due to its database managing capability, speed and cheap in maintenance given that this is a school project.

### **5.2.2.5 Ionic**

Ionic is an open source, cross-platform framework/ UI toolkit for developing high-quality cross-platform/hybrid mobile applications for native iOS, Android, and the web—all from a single codebase (Ionic, 2019). Ionic is a mobile app development framework based on the HTML5 programming language. Ionic Framework makes it possible to use familiar web technologies and improves a developer productivity when it comes to setting up an app quickly from scratch.

### **5.2.2.6 MySQL**

For the dynamic data that are bound to change every time such as password and user name and for that data that have not been committed to the blockchain, the project opted for the most popular open source database system

## **5.2.3 System Users and Graphical User Interface**

### **5.2.3.1 Landing Page**

Figure 5.1 shows the web graphical user interface of the system of the homepage. Figure 5.2 depicts the mobile application graphical user interface landing page of the system. The user is able to register if they are not already registered or login to their profile if they already have an account in the system.

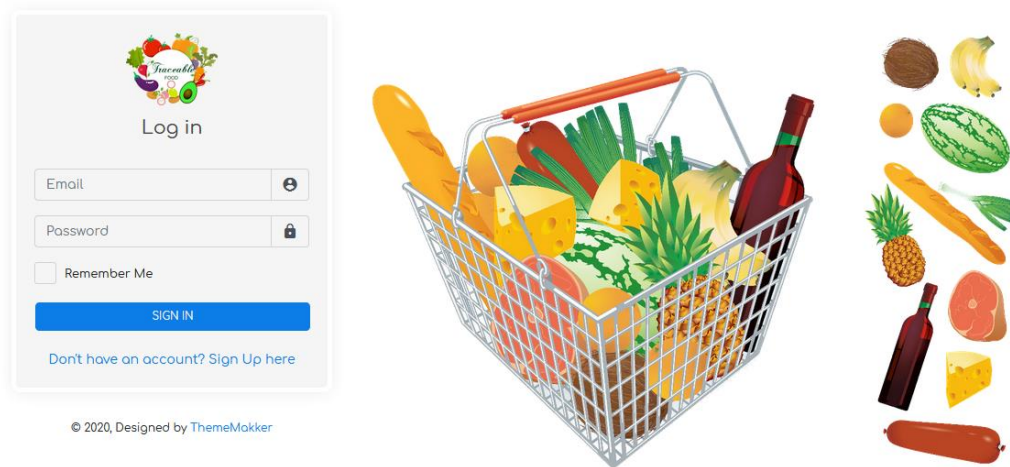
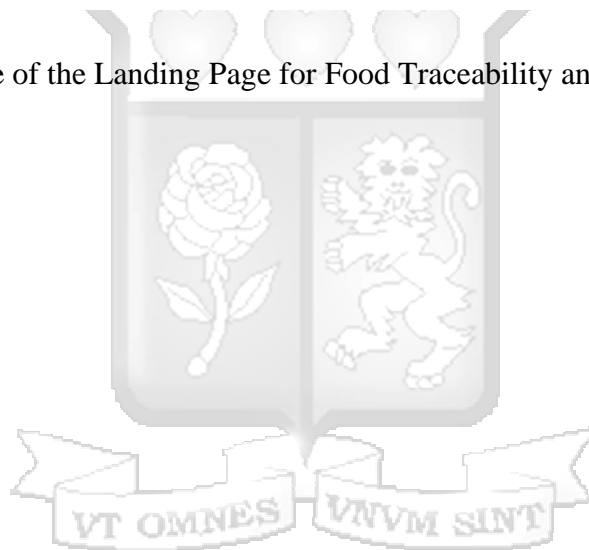

Figure 5.1: Web Interface of the Landing Page for Food Traceability and Safety System



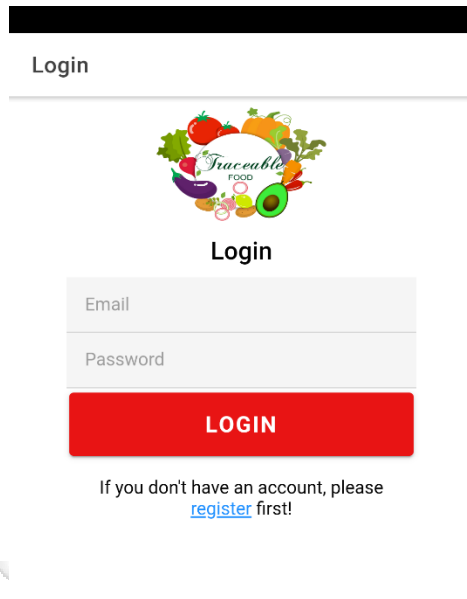

Figure 5.2 : Mobile Interface of the Landing Page for Food Traceability and Safety System

### 5.2.3.2 Sign-Up page

Figure 5.3 depicts the sign up page for the web interface. Figure 5.4 on the other hand shows the signup page for mobile devices. A user has an option to create an account as a customer/consumer, as processing company or as a farmer.

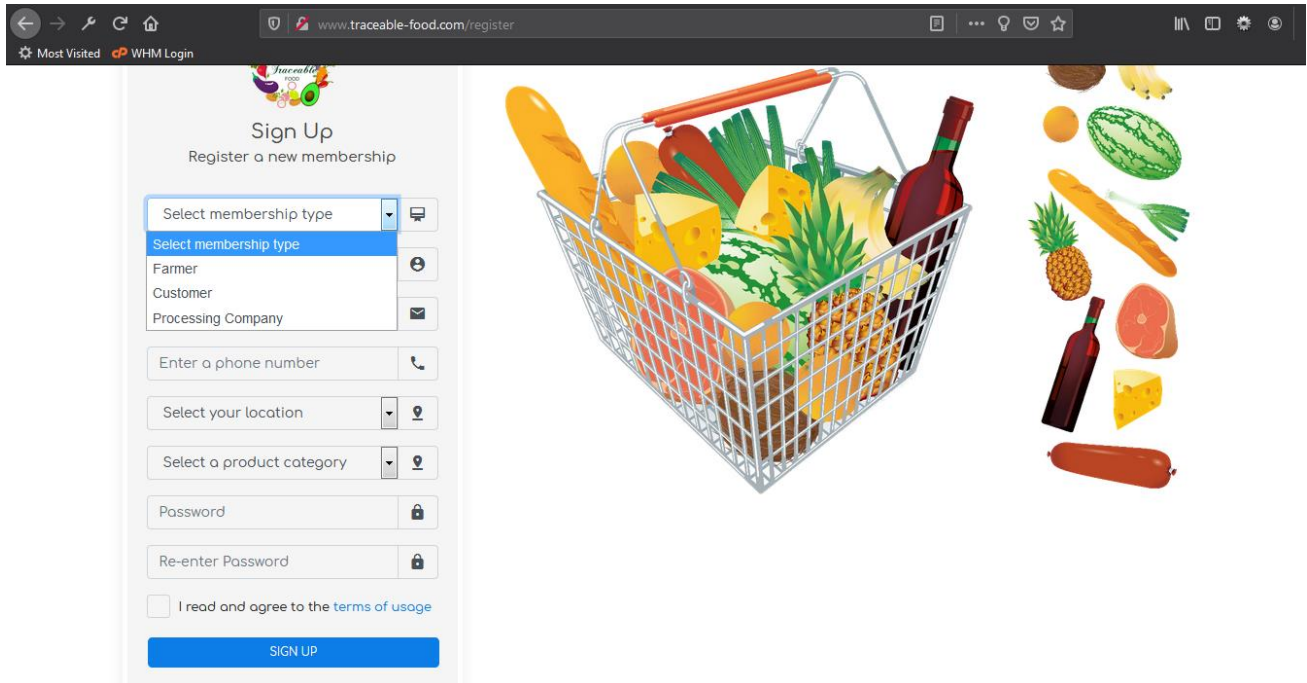
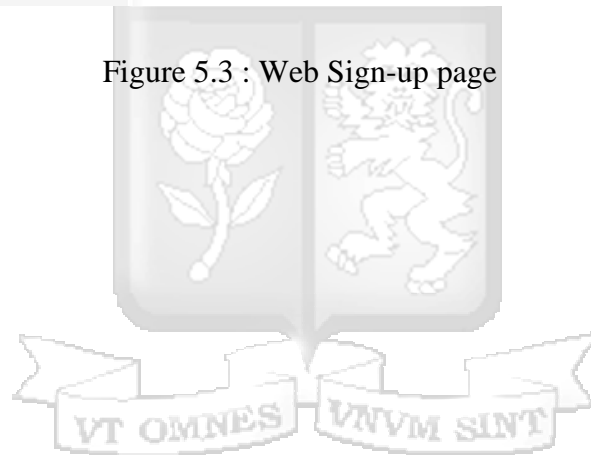

Figure 5.3 : Web Sign-up page



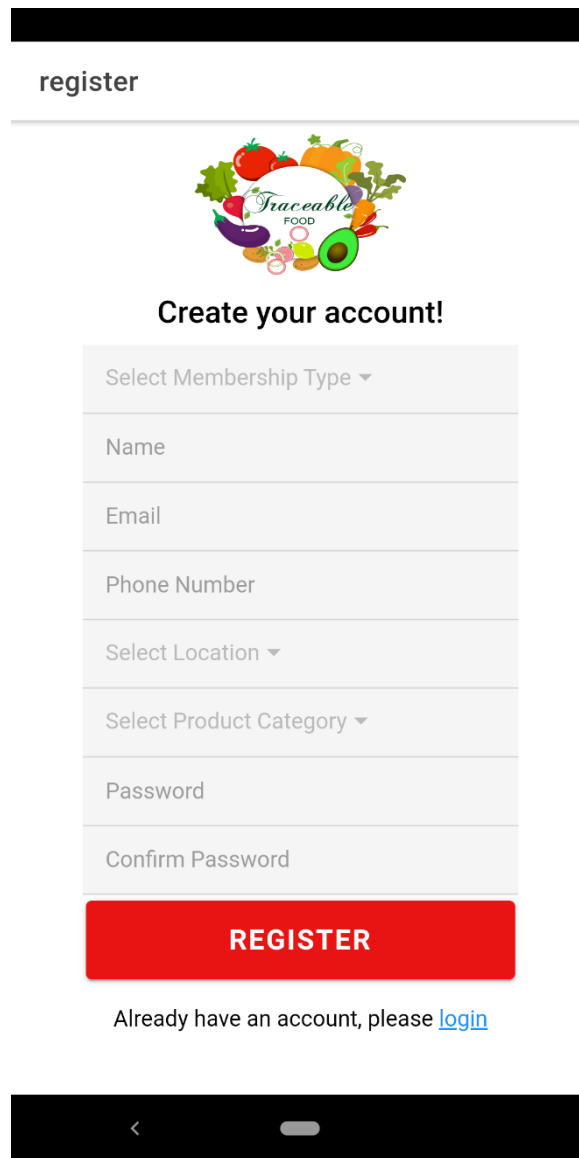

Figure 5.4 : Mobile Sign-up page

#### 5.2.3.4 User Roles

- i. **Customer:** Buys agricultural produce or processed agricultural produce from the system.
- ii. **Farmer:** Sells agricultural produce through the system, to the consumers or to the processing companies either directly through the system, or via wholesalers.
- iii. **Food Processing Companies:** Buys agricultural produce from farmers through the system and sells processed products to the customers either directly or indirectly through the wholesalers through the system

- iv. **Government:** certify the farmers, and the processing companies and keeps an oversight of the transaction over system. They also take part in the validation phase of the block chain process
- v. **Super Admin:** Manages users and is able to keep an oversight over the system transaction without being able to change user's inputs.

### 5.2.4 User Roles and Graphical User Interface

Users are able to carry out various actions on the systems depending on the user roles that applies to the user. Other than customer user roles, all other users must be verified by the government and certified. Figure 5.5, illustrates this

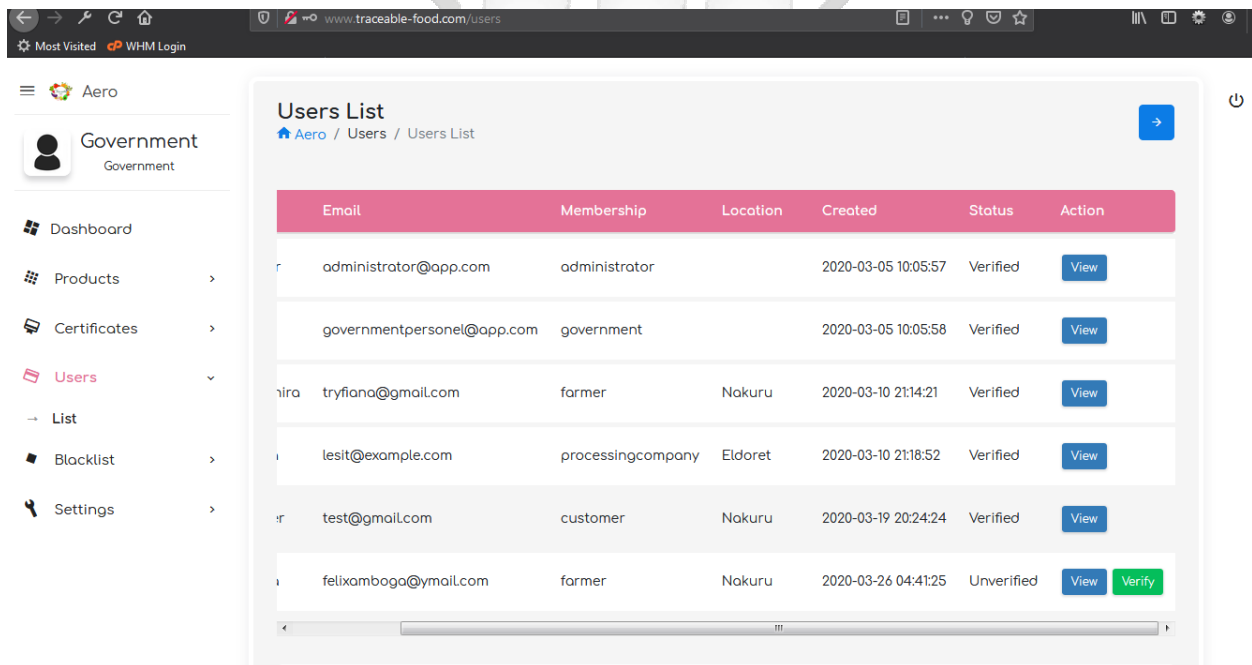

Figure 5.5 : Verification Page of the System by the Government User Role

#### 5.2.4.1 Farmer User Role

The farmer ones logged is will be able to see the graphical interface illustrated in Figure 5.6.

- I. **Update Products:** The farmer is able to update their products catalogue including the pictures of the product

- II. **Sale:** The farmer is able to confirm a sale from a customer. After confirmation of the sale. The product false off the catalogue
- III. **Rate/Flag:** rate a customer or processing company or flag them.

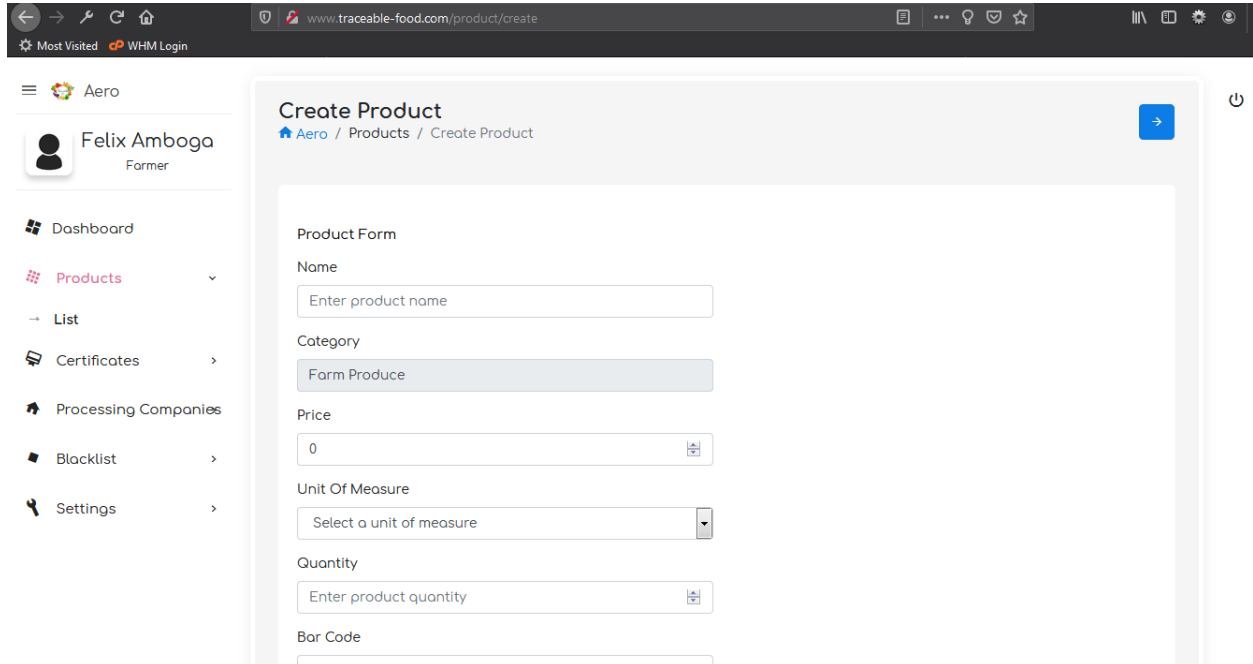

Figure 5.6 : Parent Profile Dashboard - Web Impression

#### 5.2.4.2 Government User Role

Figure 5.6 illustrates the various modules or roles that the government representative is able to perform:

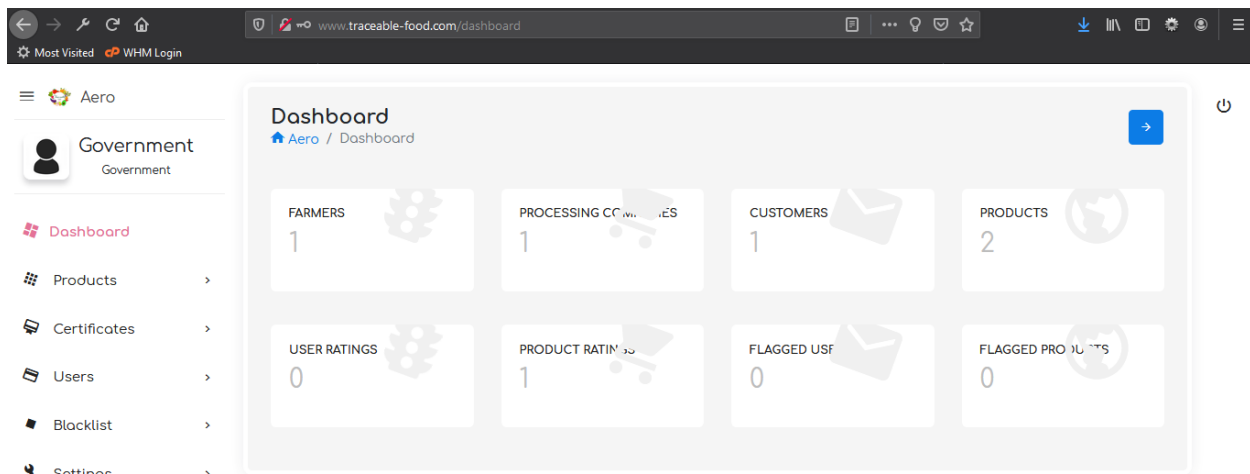

Figure 5.7 : Government User Role - Web Impression

- i. **Overview of Users:** The representative is able to know how many farmers/companies/consumers are registered in the system and from which counties they are based. They are able to contact them via the system.
- ii. **Over View of Rating/Flagging:** They are able to see consumer rating of products/produce thus showing good product/produce or flagging of the same indicating a problem with a product/produce.
- iii. **Validate and Certify Users:** When a farmer or processing company creates an account they must be verified by various nodes. Government is one of the nodes that takes part in this process. They also certify, the farmers/processing companies as legit and allowed to carry out business.
- iv. **Blacklist a Farmer/processing Company:** If flags on a product are a number and from different regions, then there is cause for concern. The government can blacklist the product so that it is not shown on the system at all for sale. A farmer, or processing company that has had a lot of flags can also be investigated and blacklisted in the system and their certification withdrawn.

### 5.2.4.3 Customer User Role

Figure 5.8 illustrates the customer landing page when they login into the system.

- i. **Browse Catalogue:** The user is able to check the system catalogue, read the information regarding the production of the produce or product in question and make purchase of farm produce/product
- ii. **Scan a Product:** When a user scans a bar code of a product or produce, they are provided by information about the production of the produce or product in question.
- iii. **Browse by Farmer/ Processing Company:** A customer may have trust on a certain farmer/processing company and hence go to their profile directly to buy from the given farmer catalogue.

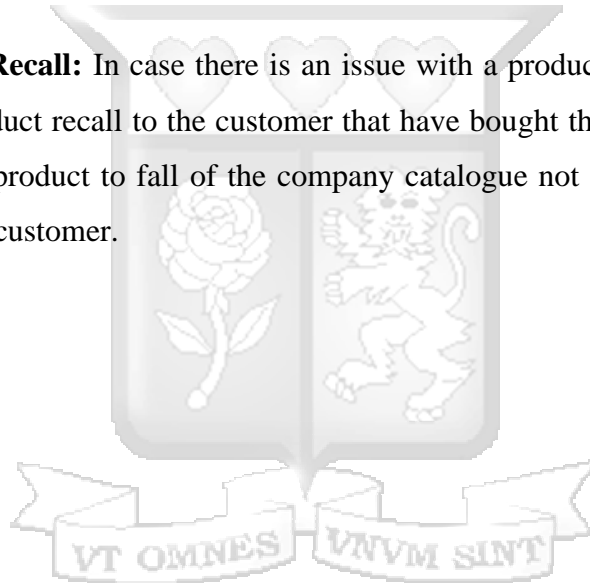

Figure 5.8 : Customer/Consumer Role Dashboard

#### 5.2.4.4 Processing Company User Role

Commodity student's dashboard is as illustrated in Figure 5.10. The following are explanations of the modules in the student's dashboard:

- i. **Catalogue Management:** the company will be able to update their catalogue, accept product sale and manage their products.
- ii. **Scan a Product Bar Code:** the company will be able to scan a product and be able to read all information pertaining to the product scanned
- iii. **Browse Farm Produce/Products:** the company is able to buy farm produce as raw materials for their products. They are able to do this and make payment to the farmer
- iv. **Product Recall:** In case there is an issue with a product, the company is able to make product recall to the customer that have bought the product. The recall will force the product to fall of the company catalogue not to be bought anymore by any other customer.



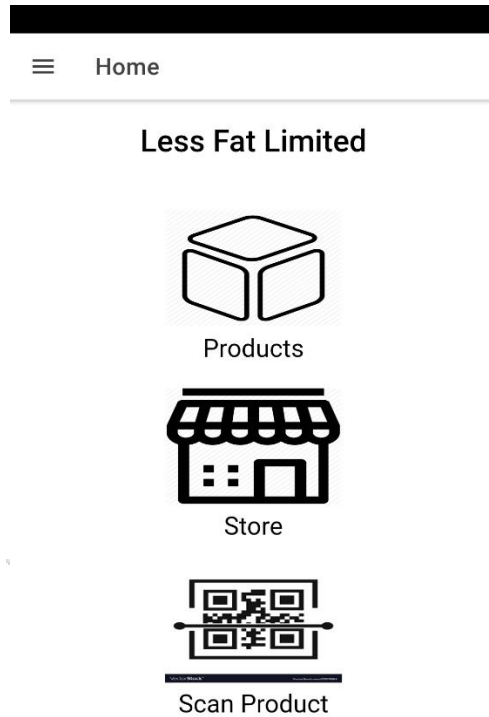

Figure 5.9 : Processing Company Role Dashboard

#### 5.2.4.5 Super Administrator User Role

Figure 5.10 depicts the graphical interface that the super administrator meets when they log in to the system.

- i. **Management of Users:** The representative is able to know how many farmers/companies/consumers are registered in the system and from which counties they are based. The account is able to change password for the user and change user roles from customer for instance to Farmer. In case of changing of the role, the user will have to be validated afresh.

- ii. **Over View of Rating/Flagging:** They are able to see consumer rating of products/produce thus showing good product/produce or flagging of the same indicating a problem with a product/produce.

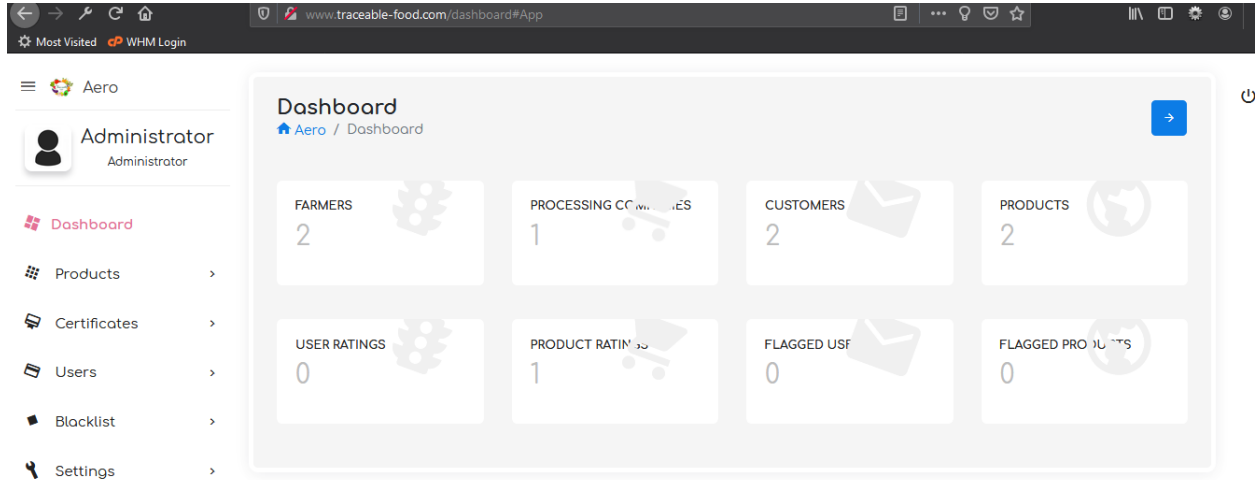
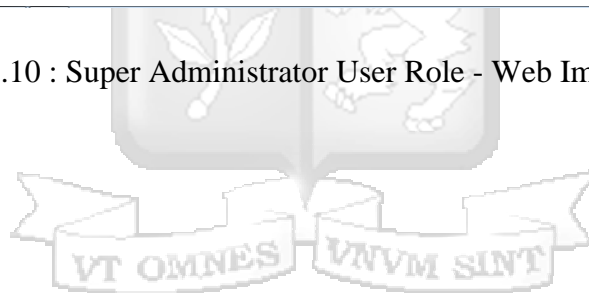

Figure 5.10 : Super Administrator User Role - Web Impression

### 5.3 System Testing



#### 5.3.1 Functional Testing

Functionalities identified in Chapter 4 formed the basis of tests done as outlined on Table 5.1 with an overview of the test variables and the test results.

Table 5.1 : Functional Testing Variables and Results

Test Class	Inspection Check	Priority level	Test Results
Functional	Does the system have a mobile application interface for farmers/consumers/Processing	High	Pass

	Companies		
<b>Functional</b>	Does the system enable users to scan Bar Codes of products to get more information of the product	High	Pass
<b>Functional</b>	Does the system enable customers to browse products based on their location or the location most convenient	High	Pass
<b>Functional</b>	Does the system help suppliers sell their commodity through the system	High	Pass
<b>Functional</b>	Does the system enable customers to rate or flag products or user (farmers/company)	High	Pass
<b>Functional</b>	Does the system enable government agency to blacklist a product or user (famer/company)	High	Pass
<b>Functional</b>	Does the system enable the company to recall a product that has already been release to the market	High	Pass
<b>Functional</b>	Does the system enable the government to verify and certify users(farmers/company)	High	Pass

### 5.3.2 Usability Testing

Given the analysis on chapter 4, the project developed a web base interface for the Government and the Super Administrator and a mobile application for farmers, processing companies and customers.

The project consulted the consumers/customers on how intuitive the system was when they interacted with the system.

Figure 5.11 illustrates customers' response to the question: "How easy is it find what you are looking for" with 75% approval rate.

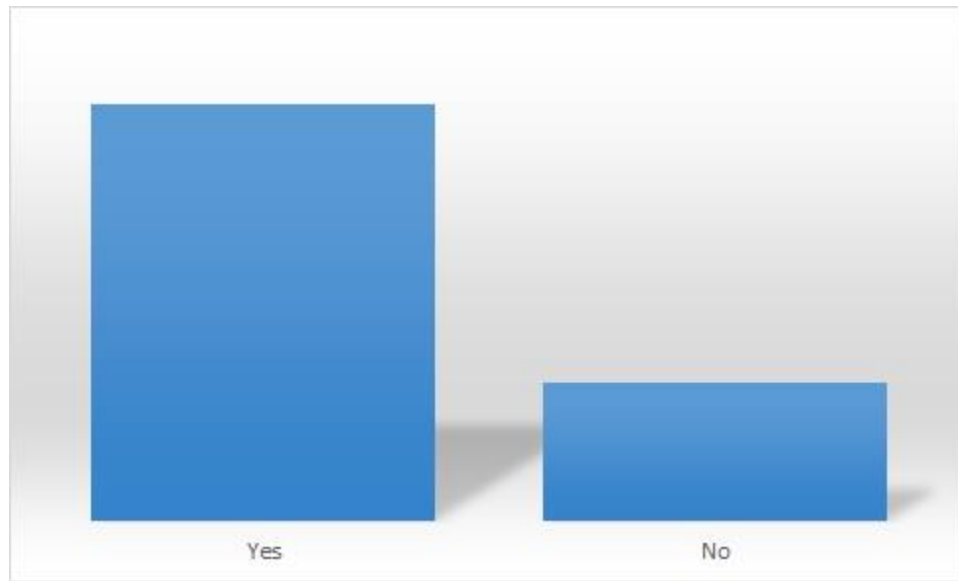

Figure 5.11 : Customers' Usability Feedback

### 5.3.3 Regression Testing

#### 5.3.3.1 Customer Browsing the Catalogue

Figure 5.12 illustrates the customer view of product catalogue. The user is able to browse by location or product name

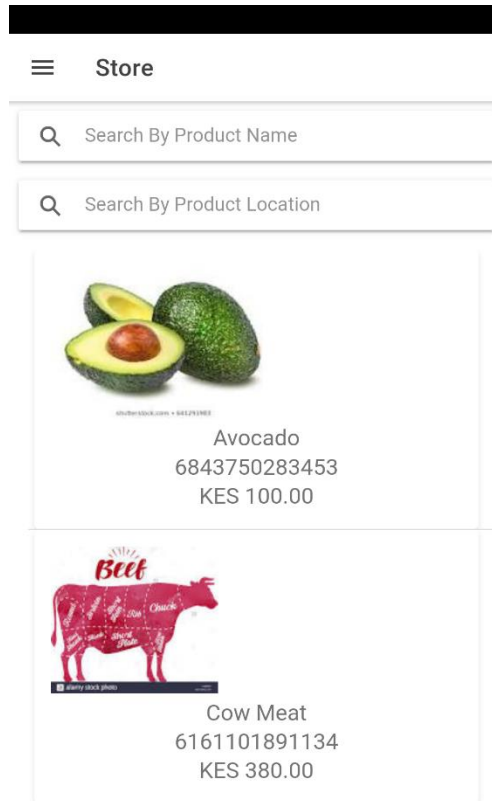

Figure 5.12 : Catalogue View for Customer

### 5.3.3.2 Customer Reading the Product Details

Figure 5.13 illustrates the view of production information for traceability purposes. Here the user is able to know all kind of information about the produce or product in question so as to make an informed decision

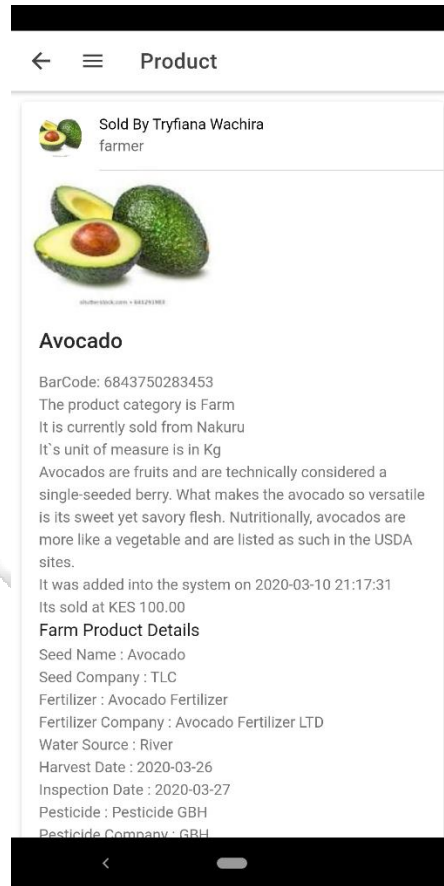

Figure 5.13 : Product Information View for the Customer

### 5.3.3.3 Customer Scanning Bar Code

Figure 5.14 shows the view where the user is able to scan a product so as to be shown information as displayed on Figure 5.13 as discussed previously.

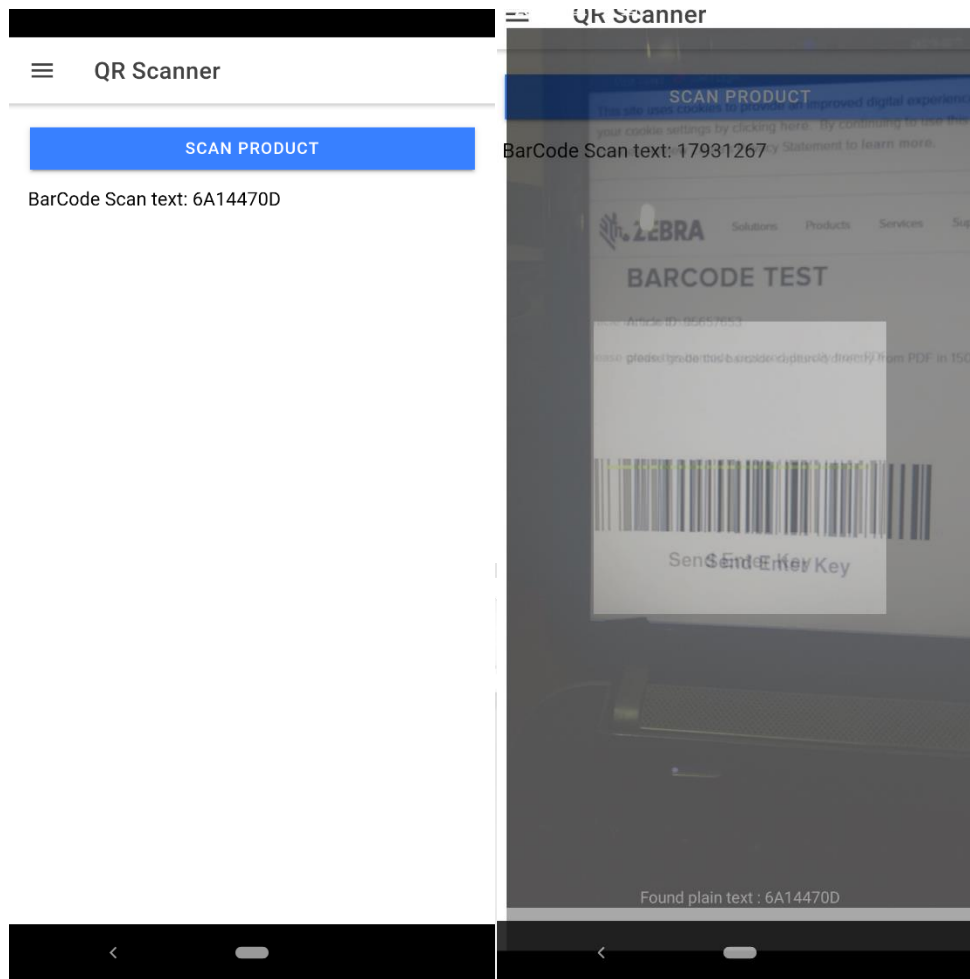

Figure 5.14 : Bar/QR Code Scanner

### 5.3.5 Compatibility Testing

The web application was tested on two main browsers for compatibility. The table 5.8 show the results from this test

Table 5.2 : Web Compatibility Test Results

Type of web browser	Compatibility acceptance
Google Chrome version 80(official build) and above	Yes
Mozilla Firefox Version 64 and above	Yes

With android having larger share of market in term of the mobile device operating system, the project focused on the on the development of the mobile application to run on android. This was tested on Android 4.4 and above with the results shown on Table 5.9

Table 5.3 : Mobile Operating System Compatibility Test Results

Type of mobile Operating System	Compatibility acceptance
Android 4.4 and above	Yes



## **Chapter 6: Discussion**

### **6.1 Introduction**

This chapter gives a deeper insight into the block chain applications that seeks to enhance Food Traceability and Safety. The scope of this project is limited to the master's level, but the project has a much larger scope that be covered in this project conclusively. We therefore, touch upon some of the aspects that we were unable to cover in this project.

### **6.2 Findings and Achievements**

There is general consensus across board that indeed foodborne disease is a major concern in Kenya. This was regardless of whether the respondents were a farmer, customer of processing company representative. In the recent future, Kenya has had numerous cases of food contaminations spanning from sugar with mercury; to contaminated maize grains; to issues of vegetables planted in a sewerage area or watered using sewerage wastewater; to harmful pesticides burned in European countries being used locally to cultivate our vegetable.

Farmers believe that the system will remove a lot of middlemen in their supply chain and hence increase their income by cutting on their costs. The costs cut by buying the pesticides/fertilizer directly from the company without going through the retail shops and being able to sell to customers without the wholesaler's involvement.

The companies believe that the system will even help them determine which products are bought in what areas. This will help them in targeted marketing of their products. It will be easy for the company to recall the products that is defective as they will be able to contact the customers directly from the system.

### **6.3 Review of Research Objectives in Relation to the Mobile Application**

The first objective of the project was to investigate the various actors and stakeholders in food supply chain in Kenya. The project identified many stakeholders in the supply chain and noted

that it was beyond the scope of this study to delve into all of them. The project focussed on customers, farmers and processing companies as the main the stakeholders of this work

The works second object was to analyse current techniques, models and technologies used in blockchain technology. The project found that blockchain is driving innovation in solving societal problems. The areas that have notably benefitted from blockchain technology is financial sector with the implementation of crypto currency. Due to secure nature of this framework, many expert's font it as the solution to many of the society problems involving contractual agreement.

The third objective of the project was to develop a system that enhance food traceability and safety by employing block chain technology. This project has developed a mobile application that is powered by a blockchain framework, decentralised framework that seeks to ensure transparency in the food supply chain.

The project sought to ensure and validate that the block chain technology powered system enhances food traceability and safety by providing transparency to stakeholders and decentralization in the food supply chain. This was done by employing various test methodology as discussed in chapter 5 of this work.

#### **6.4 Advantages of the Application in Contrast with the Current System**

The biggest advantage of the system is that on a tap of a button, a Kenyan will be able to get the basic information about the agri-products they are about to buy or consume. They are able to know where their food was grown, how it was transported and how it was processed before getting to his table. They will have the location of where the whole processes started and hence be able to track his food from the source to the fork. This is a system that Kenyans are currently missing.

Currently, farmers have to physically visit KEBS offices to get certification to sell their products (KEBS, 2020). They record the details in a ledger system that notify them of an elapsed certification and they have to do an email to the farmer to renew the certification afresh (OBWOGO, 2020). The current ledger systems do not hold any helpful data apart from the certification or licences of the company or farmer. The current system is merely there to record

that a certain company exists. It's a push system that does not pull information into it. Needles to mention, farmers that will take the trouble to visit the KEBS offices are ones that would like export their produce. For the farmers aiming to sell their produce locally on the open air market, will see the visit as, unnecessary time consuming tasks as KEBS has no mechanism to enforce the need of the certification locally.

The system will serve as a data reservoir of processing companies, and registered farmers; a key informational tool for the government, decision makers and public at large.

### **6.5 Limitations of the Application**

Due to the scope of the project, given that this is a school project without much budget allocation, the project neither employed radio-frequency identification (RFID), GPS nor sensors on the real time tracking of the transport trucks or at the warehouse. It largely depends on the data input by the farmer of the processing company. From experience the data input can be compromised knowingly or unknowingly during the data entry stage. Tian (2018) on her work automated the key stages in agri-food supply by use of sensors, RFIDs and GPS to ensure more reliable data. The margin of error is then reduced due to this automation, something that the project is missing

Though most of the respondents opted for the mobile phone as mode of access for the system, most farmers are not generation Y or Millennial. They are therefore not technology savvy and though the system is made to be as intuitive as possible, some the users will still have challenges with system.

Though internet spread in Kenya has really grown, still there are areas, especially in the rural areas where most farmers are based, that have intermittent internet connection. This will greatly affect the application as it is solely internet driven system

### **6.6 Application, Efficiency and Ease of Use**

The system has two user interfaces. The normal users – farmers, consumers and processing company will access the system via mobile devices. The super administration and the

government or the regulatory authorities will have access through a web interface. The application allows the customer to buy agri-product at a tap of a button in the system. This they are able to do after getting full information about the produce they are about to buy including the raw material used in the production phase.

The information is in public domain to anyone who uses the mobile application. The customers are able to flag a bad product to get the attention of the regulatory authority. If the flags are too many and random, the farmer or the processing company may be blacklisted, therefore rendering them unable to do business through the application. They may be forced to recall the product from the market. This will also go out as a warning to all users registered not buy s certain product from a certain farmer/processing company due to health concerns.

The farmers and processing companies, will be able to see from the system there regular customers and the product that is most preferred by customers. This data can enable them plan their product or production according to meet demand and this not lose customers. They are also able to setup reward system for the regular customers to encourage more sales. The government is able to get key data on sales and hence an indication on taxes and to be able to mine data on eating habits of its citizens and thus plan accordingly in case of a pandemic like the on one 2020.

The system has been simplified to make using the system easy to anyone. The dashboard is pretty much self-explanatory with modules clearly labelled to make navigation easy for users. When a customer logins, they are given an option of scanning product to get information of the product, for instance in a supermarket. This is quick way to get the information needed on the product. They are also able to browse by particular farmer that always have good product or a processing company. Or they can browse the catalogue of all products by going through the store. This is shown on Figure 5.8 in chapter 5.

## **Chapter 7: Conclusions, Recommendations and Future Work**

### **7.1 Introduction**

Developing a mobile application driven by blockchain technology that enable users to trace food produce from the farm to the fork was the main objective of this project. At a click of a button the stakeholders would have information about the produce they are about to buy. This will help in making informed decision in terms of what to consume and what not to consume. In case of foodborne breakout, it will be easy to recall the products of produce at a click of a button in the system.

The motivation of this project is the constant challenge of foodborne diseases or food contamination in Kenya. These scandals always end with no prosecution, with the general public being the losers as they are exposed to potential harmful foodstuff. With a transparent application, the public can be able to trace who was capable and use this information in courts of law to seek accountability or agitate for boycotting of certain products.

### **7.2 Conclusions**

Foodborne disease is a universal scenario, a challenge that most if to all countries have registered at one point in time. However, in Kenya, the issue is compounded by the run-away corruption which abated by luck of a system that will entrench transparency and accountability, hence it is not even possible to know who was culpable for the food poisoning. In rare circumstances where the suspects are known, they are able to doctor documents to show otherwise and hence do away with the evidence. This has seen an increase in food contamination cases, including cases concerning the maize, the sugar and vegetable. Some experts have linked the increase of cancer cases in Kenya to the contamination of food products that are entering Kenyan market.

The insight to come up with this project was derived from the above reasons among others. Having an application that can give consumers information regarding the product or produce that they are about to buy and thus consume, with the information on this system being incorruptible and persists forever. The system will be able to generate reports from flagged products by the

consumers. These reports can be used in court of law to hold the culpable accountable for their actions.

With information from the system, the Kenyan government can get rich information that will help in planning for food security, health system of the country and fiscal planning of the country. With information from the system, the regulatory authorities have an overview on the supply chain and due to this foresight they are able to be proactive instead of being reactive to pandemic after they have taken place, which might be a little too late.

### **7.3 Recommendations**

This is a perfect system for Kenya Bureau of Standards, Office of Attorney General, Ministry of Industrialization, Kenya Revenue Authority and Ministry of Agriculture, if to mention but a few. These bodies will be able to use the application to enforce standards, track sales and hence get an idea of revenues generated, and keep abreast of the happenings in the agricultural and manufacturing industries.

The system would help the government get data that are key in planning food security; this would also help the government understand the eating habits of the country and even advise accordingly in case the citizens are eating unhealthy food. In a case of a breakout, they will be able to manage foodborne diseases breakout; know which industries to foster to increase food production; know when to intervene and how to intervene in case of extortion by either parties and finally collect the right revenues the sales.

If the application is done to the full scale, the automation of the collection of data will be critical. The use of the GPS, sensors, and Radio-frequency identification (RFID) will must be used in the tracking of the delivery vehicle as well as collect data on the frame and on the warehouses. Having the fertilizer, seed and insecticides producing companies registered in the system will ensure that the government gets an overview of the chemicals used and the production procedures during the production process. This will ensure that whenever there is an element that is burned globally or one that has raised concerns such as glyphosate (RoundUp); an element classified by the World Health Organization as a possible a carcinogen (The Non-GMO Project,

2016), an element that causes cancer, infertility and birth defects etc - to be detected early and the processing shut down in time before greater damage is done.

Right to healthy food is one of Kenya's economic and social rights which the state is required to achieve. Consumer Federal of Kenya (COFEK) sued the government for failing to stabilise fuel prices which triggered increase in food prices in 2011 (Agostinho, 2019). This goes to demonstrate the how grave the issue of the food security is to a country. The government therefore would greatly benefit from this system in terms of following the trend of food prices and the demand and supply pull and use that information to know where they can intervene and makes thing better for Kenyans.

The system will not eliminate the occurrence of foodborne diseases but because of the information it provides, the relevant stakeholder will know when a problem has taken place, where it has originated and therefore be able to make informed decision that may reduce the impact of the breakout. It will also curtail an occurrence by the fact that the stakeholders knows that there is a big brother watching and hence they have to play by the book.

#### **7.4 Future Work**

The project is viable for solving a problem that has bedevilling Kenyans for a while. Some areas that the platform can be expounded to cover include.

- i. Creating nodes for all stakeholders of the government to tap into the very important information that will be collected in the system. Some of the government agencies and ministries that will be major stakeholders include Kenya Bureau of Standards, Office of Attorney General, Ministry of Industrialization, Kenya Revenue Authority, Ministry of Agriculture and Ministry of land. The ministry of health and internal planning can use the data from the system to plan on the type of health care facilities to put in place and the kind of food to plan for in terms of food security for the country.
- ii. The system should be expounded to get data on types of soil used, the pH of the soil, the type and source of water used. This data would help the health practitioners understand why some disease strain are not common in a certain area while common in another and

help with planning to see that the right produce get to all Kenyans so that all Kenyans are healthy.

- iii. Enforcing the companies to enter there tracking and warehouse data would encourage standardized and best practices in warehousing. Some of the contamination happen on road or on storage and by bringing it up to the lime light, more attention will be given to it which is good for enhancing best practices.
- iv. The government can use the system to give incentives to the farmers registered by giving them tax cuts so that many famers can register into the system. This will encourage farming in the country and enhance food security for the country.



## REFERENCES

- Namunwa, K. (2019). Kenya leads Africa in Smartphone usage - Business Today Kenya. Retrieved 3 April 2020, from <https://businesstoday.co.ke/kenya-leads-africa-smartphone-usage/>
- Agostinho, N. (2019). Attaining food security is a complex task for which the primary responsibility rests with individual governments. *Cha Kula*, (2), 24.
- The Non-GMO Project (2016). What is a GMO? Retrieved April 9, 2019, from <https://www.nongmoproject.org/gmo-facts/what-is-gmo>
- OBWOGO, S. (2020). What it takes to get Kebs certificate. Retrieved 13 April 2020, from <https://www.nation.co.ke/business/seedsforgold/What-it-takes-to-get-Kebs-certificate/2301238-4717448-147qmmq/index.html>
- KEBS, K. (2020). Kenya Bureau Of Standards (KEBS). Retrieved 13 April 2020, from [https://kebs.org/index.php?option=com\\_content&view=article&id=115&Itemid=428](https://kebs.org/index.php?option=com_content&view=article&id=115&Itemid=428)
- Coronavirus Disease (COVID-19) - events as they happen. (2020). Retrieved 2 April 2020, from <https://www.who.int/emergencies/diseases/novel-coronavirus-2019/events-as-they-happen>
- Chain, A., Production, R. A. W. M., & Processors, F. (n.d.). *STAKEHOLDERS AND ACTIVITIES IN THE AGRI-FOOD SUPPLY CHAIN* List of contents, 1–12.
- Shavelson, R. J., & Towne, L. (Eds.). (2002). *Scientific research in education*. Washington, DC: National Research Council, National Academy Press.
- Boaz, A., Ashby, D., & Mary, Q. (2003). *Fit for purpose ? Assessing research quality for evidence based policy and practice*, (January).
- Laerd, D. (2019). *Reliability in research | Lærd Dissertation*. Retrieved from <http://dissertation.laerd.com/reliability-in-research.php>
- Lohr, K. N. (2004). Rating the strength of scientific evidence: Relevance for quality improvement programs. *International Journal for Quality in Health Care*, 16(1), 9–18.
- Boaz, A., & Ashby, D. (2003). *Fit for purpose? Assessing research quality for evidence based policy and practice*. London: ESRC UK Centre for Evidence Based Policy and Practice.
- Etikan, I. (2017). *Comparison of Convenience Sampling and Purposive Sampling Comparison of Convenience Sampling and Purposive Sampling*, (January 2016). <https://doi.org/10.11648/j.ajtas.20160501.11>
- Arkkelin, D. (2014). *Using SPSS to Understand Research and Data Analysis*.
- Etikan, I. (2017). *Comparison of Convenience Sampling and Purposive Sampling Comparison of*

- Convenience Sampling and Purposive Sampling, (January 2016).  
<https://doi.org/10.11648/j.ajtas.20160501.11>
- Matters, Q. (2004). Focus, (9).
- Wong, S. (2002). Design and Applications of a Multimodality Image Data Warehouse Framework. *Journal of The American Medical Informatics Association*, 9(3), 239-254. doi: 10.1197/jamia.m0988
- Bauer, L. (2019). Agile Methodology and System Analysis. Retrieved from <http://www.umsl.edu/~sauterv/analysis/Agile%20Methodology%20and%20System%20Analysis.htm>
- German, C. (2015). Agriculture and Rural Development.
- Commons, W. (2017). File:Blockchain-Process.png - Wikimedia Commons. Retrieved from <https://commons.wikimedia.org/wiki/File:Blockchain-Process.png>
- Rosic, A. (2019). Blockchain Tutorial | How To Become A Blockchain Developer:. Retrieved from <https://blockgeeks.com/guides/blockchain-developer/>
- Chain, A., Production, R. A. W. M., & Processors, F. (n.d.). STAKEHOLDERS AND ACTIVITIES IN THE AGRI-FOOD SUPPLY CHAIN List of contents, 1–12.
- Control, Q. (n.d.). Quality Assurance , Quality Control and Testing — the Basics of Software Quality Management.
- Etikan, I. (2017). Comparison of Convenience Sampling and Purposive Sampling Comparison of Convenience Sampling and Purposive Sampling, (January 2016).  
<https://doi.org/10.11648/j.ajtas.20160501.11>
- Fuad, M. M., Deb, D., & Etim, J. (2014). An evidence based learning and teaching strategy for computer science classrooms and its extension into a mobile classroom response system. *Proceedings - IEEE 14th International Conference on Advanced Learning Technologies, ICALT 2014*, 149–153. <https://doi.org/10.1109/ICALT.2014.52>
- Gamage, R., & Dong, H. (2006). JavaScript tools for online information retrieval. *Online Information Review*, 30(4), 380–394. <https://doi.org/10.1108/14684520610686779>
- German, C. (2015). Agriculture and Rural Development.
- Goyal, G., Singh, K., & Ramkumar, K. R. (2017). A detailed analysis of data consistency concepts in data exchange formats (JSON & XML). *2017 International Conference on Computing, Communication and Automation (ICCCA)*, 72–77.  
<https://doi.org/10.1109/CCAA.2017.8229774>
- Guo, S., Xia, H., & Xiang, G. (2017). Research on the Translation from XSD to JSON Schema, 0–3.

- Holmberg, A. (2018). Blockchain technology in food supply chains.
- Jacob-john, B. J., & Veerapa, N. (2015). Stakeholder perception of the ethics of an industry : The case of organic food in South India, 151–160. <https://doi.org/10.14207/ejsd.2015.v4n3p151>
- Lee, R. (n.d.). Food as a weapon.
- Miragliotta, G., & Engineering, I. (2018). Tracing and tracking with the blockchain.
- Tian, F. (2018). ePub WU Institutional Repository, (March).
- Sutherland, J. (2019). Why Waterfall Doesn't Scale - Scrum Inc. Retrieved from <https://www.scruminc.com/waterfall-doesnt-scale/>
- Bauer, L. (2019). Agile Methodology and System Analysis. Retrieved from <http://www.umsl.edu/~sauterv/analysis/Agile%20Methodology%20and%20System%20Analysis.htm>
- Chain, A., Production, R. A. W. M., & Processors, F. (n.d.). STAKEHOLDERS AND ACTIVITIES IN THE AGRI-FOOD SUPPLY CHAIN List of contents, 1–12.
- Control, Q. (n.d.). Quality Assurance , Quality Control and Testing — the Basics of Software Quality Management.
- Etikan, I. (2017). Comparison of Convenience Sampling and Purposive Sampling Comparison of Convenience Sampling and Purposive Sampling, (January 2016). <https://doi.org/10.11648/j.ajtas.20160501.11>
- Fuad, M. M., Deb, D., & Etim, J. (2014). An evidence based learning and teaching strategy for computer science classrooms and its extension into a mobile classroom response system. *Proceedings - IEEE 14th International Conference on Advanced Learning Technologies, ICALT 2014*, 149–153. <https://doi.org/10.1109/ICALT.2014.52>
- Gamage, R., & Dong, H. (2006). JavaScript tools for online information retrieval. *Online Information Review*, 30(4), 380–394. <https://doi.org/10.1108/14684520610686779>
- German, C. (2015). Agriculture and Rural Development.
- Goyal, G., Singh, K., & Ramkumar, K. R. (2017). A detailed analysis of data consistency concepts in data exchange formats (JSON & XML). *2017 International Conference on Computing, Communication and Automation (ICCCA)*, 72–77. <https://doi.org/10.1109/CCAA.2017.8229774>

Guo, S., Xia, H., & Xiang, G. (2017). Research on the Translation from XSD to JSON Schema, 0–3.

Holmberg, A. (2018). Blockchain technology in food supply chains.

Jacob-john, B. J., & Veerapa, N. (2015). Stakeholder perception of the ethics of an industry : The case of organic food in South India, 151–160. <https://doi.org/10.14207/ejsd.2015.v4n3p151>

Lee, R. (n.d.). Food as a weapon.

Miragliotta, G., & Engineering, I. (2018). Tracing and tracking with the blockchain.

Tian, F. (2018). ePub WU Institutional Repository, (March).

Swarthmore, C. (2019). Department/Program Assessment. Retrieved from <https://www.swarthmore.edu/assessment/departmentprogram-assessment>

Fuad, M. M., Deb, D., & Etim, J. (2014). An evidence based learning and teaching strategy for computer science classrooms and its extension into a mobile classroom response system. *Proceedings - IEEE 14th International Conference on Advanced Learning Technologies, ICAALT 2014*, 149–153. <https://doi.org/10.1109/ICALT.2014.52>

Gamage, R., & Dong, H. (2006). JavaScript tools for online information retrieval. *Online Information Review*, 30(4), 380–394. <https://doi.org/10.1108/14684520610686779>

Goyal, G., Singh, K., & Ramkumar, K. R. (2017). A detailed analysis of data consistency concepts in data exchange formats (JSON & XML). *2017 International Conference on Computing, Communication and Automation (ICCCA)*, 72–77. <https://doi.org/10.1109/CCAA.2017.8229774>

Guo, S., Xia, H., & Xiang, G. (2017). Research on the Translation from XSD to JSON Schema, 0–3.

Holmberg, A. (2018). Blockchain technology in food supply chains.

Jacob-john, B. J., & Veerapa, N. (2015). Stakeholder perception of the ethics of an industry : The case of organic food in South India, 151–160. <https://doi.org/10.14207/ejsd.2015.v4n3p151>

Lee, R. (n.d.). Food as a weapon.

Miragliotta, G., & Engineering, I. (2018). Tracing and tracking with the blockchain.

Tian, F. (2018). ePub WU Institutional Repository, (March).

Chain, A., Production, R. A. W. M., & Processors, F. (n.d.). STAKEHOLDERS AND

ACTIVITIES IN THE AGRI-FOOD SUPPLY CHAIN List of contents, 1–12.

- Fuad, M. M., Deb, D., & Etim, J. (2014). An evidence based learning and teaching strategy for computer science classrooms and its extension into a mobile classroom response system. *Proceedings - IEEE 14th International Conference on Advanced Learning Technologies, ICALT 2014*, 149–153. <https://doi.org/10.1109/ICALT.2014.52>
- Gamage, R., & Dong, H. (2006). JavaScript tools for online information retrieval. *Online Information Review*, 30(4), 380–394. <https://doi.org/10.1108/14684520610686779>
- Goyal, G., Singh, K., & Ramkumar, K. R. (2017). A detailed analysis of data consistency concepts in data exchange formats (JSON & XML). *2017 International Conference on Computing, Communication and Automation (ICCCA)*, 72–77. <https://doi.org/10.1109/CCAA.2017.8229774>
- Guo, S., Xia, H., & Xiang, G. (2017). Research on the Translation from XSD to JSON Schema, 0–3.
- Holmberg, A. (2018). Blockchain technology in food supply chains.
- Jacob-john, B. J., & Veerapa, N. (2015). Stakeholder perception of the ethics of an industry : The case of organic food in South India, 151–160. <https://doi.org/10.14207/ejsd.2015.v4n3p151>
- Lee, R. (n.d.). Food as a weapon.
- Miragliotta, G., & Engineering, I. (2018). Tracing and tracking with the blockchain.
- Chain, A., Production, R. A. W. M., & Processors, F. (n.d.). STAKEHOLDERS AND ACTIVITIES IN THE AGRI-FOOD SUPPLY CHAIN List of contents, 1–12.
- Fuad, M. M., Deb, D., & Etim, J. (2014). An evidence based learning and teaching strategy for computer science classrooms and its extension into a mobile classroom response system. *Proceedings - IEEE 14th International Conference on Advanced Learning Technologies, ICALT 2014*, 149–153. <https://doi.org/10.1109/ICALT.2014.52>
- Gamage, R., & Dong, H. (2006). JavaScript tools for online information retrieval. *Online Information Review*, 30(4), 380–394. <https://doi.org/10.1108/14684520610686779>
- Goyal, G., Singh, K., & Ramkumar, K. R. (2017). A detailed analysis of data consistency concepts in data exchange formats (JSON & XML). *2017 International Conference on Computing, Communication and Automation (ICCCA)*, 72–77. <https://doi.org/10.1109/CCAA.2017.8229774>
- Guo, S., Xia, H., & Xiang, G. (2017). Research on the Translation from XSD to JSON Schema, 0–3.

- Holmberg, A. (2018). Blockchain technology in food supply chains.
- Jacob-john, B. J., & Veerapa, N. (2015). Stakeholder perception of the ethics of an industry : The case of organic food in South India, 151–160. <https://doi.org/10.14207/ejsd.2015.v4n3p151>
- Lee, R. (n.d.). Food as a weapon.
- Miragliotta, G., & Engineering, I. (2018). Tracing and tracking with the blockchain.
- Tian, F. (2018). ePub WU Institutional Repository, (March).
- Chain, A., Production, R. A. W. M., & Processors, F. (n.d.). STAKEHOLDERS AND ACTIVITIES IN THE AGRI-FOOD SUPPLY CHAIN List of contents, 1–12.
- Control, Q. (n.d.). Quality Assurance , Quality Control and Testing — the Basics of Software Quality Management.
- Fuad, M. M., Deb, D., & Etim, J. (2014). An evidence based learning and teaching strategy for computer science classrooms and its extension into a mobile classroom response system. *Proceedings - IEEE 14th International Conference on Advanced Learning Technologies, ICALT 2014*, 149–153. <https://doi.org/10.1109/ICALT.2014.52>
- Gamage, R., & Dong, H. (2006). JavaScript tools for online information retrieval. *Online Information Review*, 30(4), 380–394. <https://doi.org/10.1108/14684520610686779>
- German, C. (2015). Agriculture and Rural Development.
- Goyal, G., Singh, K., & Ramkumar, K. R. (2017). A detailed analysis of data consistency concepts in data exchange formats (JSON & XML). *2017 International Conference on Computing, Communication and Automation (ICCCA)*, 72–77. <https://doi.org/10.1109/CCAA.2017.8229774>
- Guo, S., Xia, H., & Xiang, G. (2017). Research on the Translation from XSD to JSON Schema, 0–3.
- Holmberg, A. (2018). Blockchain technology in food supply chains.
- Jacob-john, B. J., & Veerapa, N. (2015). Stakeholder perception of the ethics of an industry : The case of organic food in South India, 151–160. <https://doi.org/10.14207/ejsd.2015.v4n3p151>
- Lee, R. (n.d.). Food as a weapon.
- Miragliotta, G., & Engineering, I. (2018). Tracing and tracking with the blockchain.
- Tian, F. (2018). ePub WU Institutional Repository, (March).
- Chain, A., Production, R. A. W. M., & Processors, F. (n.d.). STAKEHOLDERS AND

ACTIVITIES IN THE AGRI-FOOD SUPPLY CHAIN List of contents, 1–12.

Control, Q. (n.d.). Quality Assurance , Quality Control and Testing — the Basics of Software Quality Management.

Fuad, M. M., Deb, D., & Etim, J. (2014). An evidence based learning and teaching strategy for computer science classrooms and its extension into a mobile classroom response system. *Proceedings - IEEE 14th International Conference on Advanced Learning Technologies, ICAIT 2014*, 149–153. <https://doi.org/10.1109/ICAIT.2014.52>

Gamage, R., & Dong, H. (2006). JavaScript tools for online information retrieval. *Online Information Review*, 30(4), 380–394. <https://doi.org/10.1108/14684520610686779>

German, C. (2015). Agriculture and Rural Development.

Goyal, G., Singh, K., & Ramkumar, K. R. (2017). A detailed analysis of data consistency concepts in data exchange formats (JSON & XML). *2017 International Conference on Computing, Communication and Automation (ICCCA)*, 72–77. <https://doi.org/10.1109/CCAA.2017.8229774>

Guo, S., Xia, H., & Xiang, G. (2017). Research on the Translation from XSD to JSON Schema, 0–3.

Holmberg, A. (2018). Blockchain technology in food supply chains.

Jacob-john, B. J., & Veerapa, N. (2015). Stakeholder perception of the ethics of an industry : The case of organic food in South India, 151–160. <https://doi.org/10.14207/ejsd.2015.v4n3p151>

Lee, R. (n.d.). Food as a weapon.

Miragliotta, G., & Engineering, I. (2018). Tracing and tracking with the blockchain.

Tian, F. (2018). ePub WU Institutional Repository, (March).

Chain, A., Production, R. A. W. M., & Processors, F. (n.d.). STAKEHOLDERS AND ACTIVITIES IN THE AGRI-FOOD SUPPLY CHAIN List of contents, 1–12.

Control, Q. (n.d.). Quality Assurance , Quality Control and Testing — the Basics of Software Quality Management.

Etikan, I. (2017). Comparison of Convenience Sampling and Purposive Sampling Comparison of Convenience Sampling and Purposive Sampling, (January 2016). <https://doi.org/10.11648/j.ajtas.20160501.11>

Fuad, M. M., Deb, D., & Etim, J. (2014). An evidence based learning and teaching strategy for computer science classrooms and its extension into a mobile classroom response system. *Proceedings - IEEE 14th International Conference on Advanced Learning Technologies*,

- ICALT 2014, 149–153. <https://doi.org/10.1109/ICALT.2014.52>
- Gamage, R., & Dong, H. (2006). JavaScript tools for online information retrieval. *Online Information Review*, 30(4), 380–394. <https://doi.org/10.1108/14684520610686779>
- German, C. (2015). Agriculture and Rural Development.
- Goyal, G., Singh, K., & Ramkumar, K. R. (2017). A detailed analysis of data consistency concepts in data exchange formats (JSON & XML). *2017 International Conference on Computing, Communication and Automation (ICCCA)*, 72–77. <https://doi.org/10.1109/CCAA.2017.8229774>
- Guo, S., Xia, H., & Xiang, G. (2017). Research on the Translation from XSD to JSON Schema, 0–3.
- Holmberg, A. (2018). Blockchain technology in food supply chains.
- Jacob-john, B. J., & Veerapa, N. (2015). Stakeholder perception of the ethics of an industry : The case of organic food in South India, 151–160. <https://doi.org/10.14207/ejsd.2015.v4n3p151>
- Lee, R. (n.d.). Food as a weapon.
- Miragliotta, G., & Engineering, I. (2018). Tracing and tracking with the blockchain.
- Tian, F. (2018). ePub WU Institutional Repository, (March).
- hild, K. (2018). Polony can come back into your diet: listeria outbreak declared over. Retrieved from <https://www.timeslive.co.za/news/south-africa/2018-09-03-polony-can-come-back-into-your-diet-listeria-outbreak-declared-over/>
- Antonopoulos, A. M. (2014). Mastering Bitcoin. O'Reilly Media Inc.
- Nakamoto, S. (2008). Bitcoin: A Peer-to-Peer Electronic Cash System. Retrieved from: <https://bitcoin.org/bitcoin.pdf>.
- Kairos Future (2017). Blockchain use cases for food traceability and control: A study to identify the potential benefits from using blockchain technology for food traceability and control.
- Holmberg, A. (2018). Blockchain technology in food supply chains.
- icrc (2019). Customary IHL - Rule 72. Poison and Poisoned Weapons. [online] Ihl-databases.icrc.org. Available at: [https://ihl-databases.icrc.org/customary-ihl/eng/docs/v1\\_rul\\_rule72](https://ihl-databases.icrc.org/customary-ihl/eng/docs/v1_rul_rule72) [Accessed 20 Mar. 2019].

Lee, R. (n.d.). Food as a weapon.

Lime, A. (2018). Kenya's 'contaminated sugar' row explained. Retrieved from <https://www.bbc.com/news/world-africa-44550813>

MARETE, G., ANDAE, G., & BII, B. (2017). Controversy surrounds Mexico maize imports - VIDEO. Retrieved from <https://www.nation.co.ke/news/Controversy-surrounds-maize-importation-from-Mexico/1056-3928494-xyyb0c/index.html>

Maslow, A. (1943). A theory of human motivation. *Psychological Review*, 50(4), 370-396. doi: 10.1037/h0054346

Miya, N. (2019). Four food scandals that left a bitter taste in the mouths of South Africans. Retrieved from <https://www.timeslive.co.za/news/2018-10-30-four-food-scandals-that-left-a-bitter-taste-in-the-mouths-of-south-africans/>

Nyamori, M. (2018). Impounded sugar contains Mercury, report reveals : The Standard. Retrieved from <https://www.standardmedia.co.ke/article/2001289208/report-reveals-seized-sugar-contains-mercury>

Probst, C., Bandyopadhyay, R., Price, L., & Cotty, P. (2011). Identification of Atoxigenic *Aspergillus flavus* Isolates to Reduce Aflatoxin Contamination of Maize in Kenya. *Plant Disease*, 95(2), 212-218. doi: 10.1094/pdis-06-10-0438

Swan, M. (2015). *Blockchain*. Sebastopol, CA: O'Reilly Media, Inc.

Tian, F. (2018). ePub WU Institutional Repository, (March).

User, S. (2019). About KEBS. Retrieved from [https://www.kebs.org/index.php?option=com\\_content&view=article&id=6&Itemid=255](https://www.kebs.org/index.php?option=com_content&view=article&id=6&Itemid=255)

WHO. (2017). Food Safety: What you should know. Retrieved from [http://www.searo.who.int/entity/world\\_health\\_day/2015/whd-what-you-should-know/en/](http://www.searo.who.int/entity/world_health_day/2015/whd-what-you-should-know/en/)

WHO. (2016). 10 facts on food safety. Retrieved from [https://www.who.int/features/factfiles/food\\_safety/en/](https://www.who.int/features/factfiles/food_safety/en/)

Yli-Huumo, J., Ko, D., Choi, S., Park, S., & Smolander, K. (2016). Where Is Current Research on Blockchain Technology?—A Systematic Review. *PLOS ONE*, 11(10), e0163477. doi: 10.1371/journal.pone.0163477



## APPENDICES

### Appendix A: Time Schedule

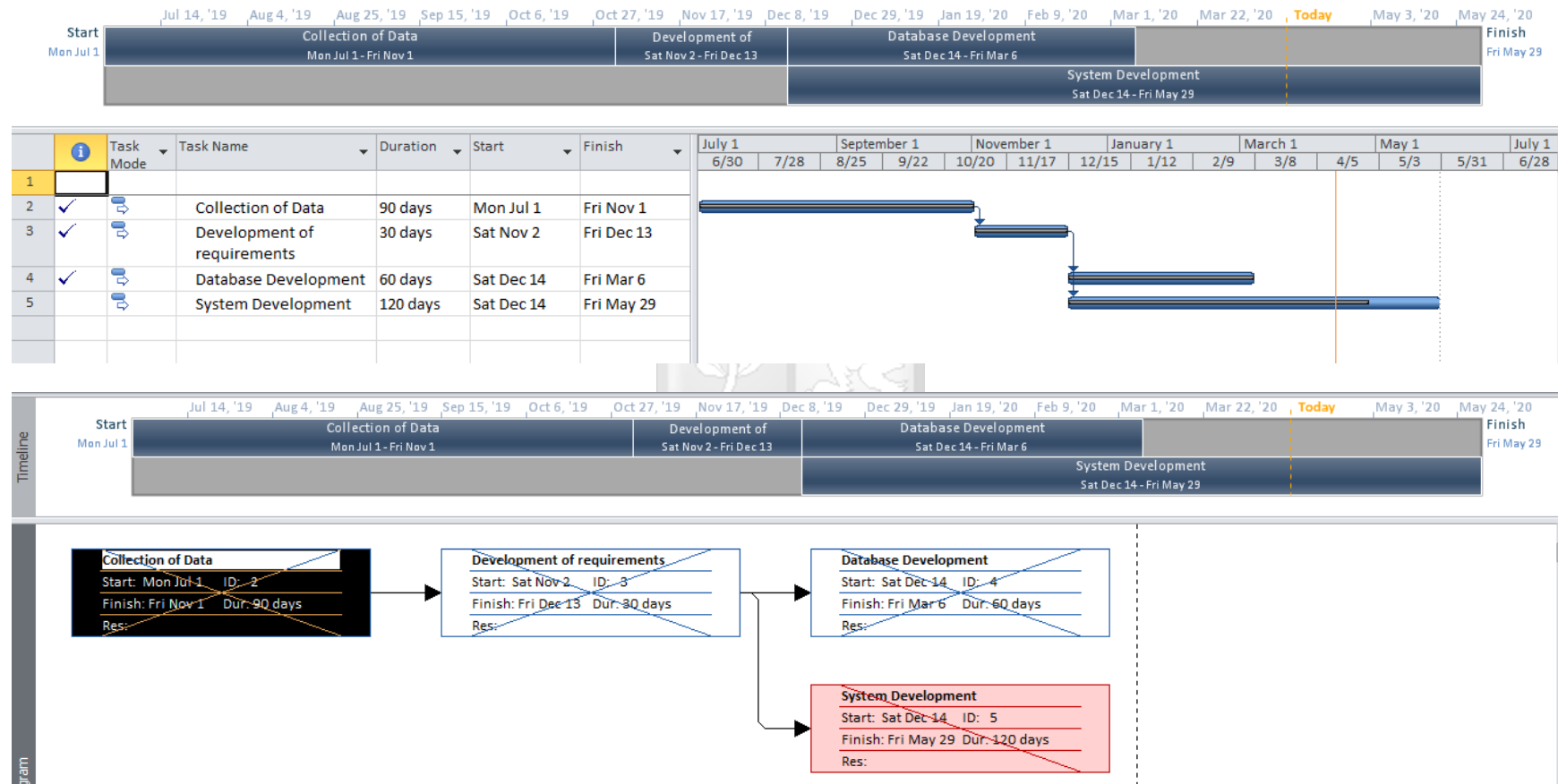

## Appendix B: Farmers Questionnaire

### QUESTIONNAIRE FOR FARMERS IN KENYA

#### Purpose

The aim of this study is to develop a system using block chain technology that will inject transparency, and decentralization in the supply chain to enhance food traceability and safety in Kenya.

#### Confidentiality

The data and/or information collected shall be treated with utmost confidentiality and shall not be shared without your prior permission.

#### Directions in responding to the Questionnaire:

1. Please check all boxes that apply in each question.
2. References to “you” or “your” refer to your farm or you as an individual.
3. “System” means a web based portal that will enable farmer to make their produce traceable and hence safe for consumers in Kenya.
4. “Products” refers to farm produce that range from animal products to fruits to grains (maize, rice beans, wheat.)

#### Correspondence/Inquiries:

Mr. Lenjula Letitoiya Lesiit (lenjula@gmail.com)

P.O. Box XXX - 00100, Nairobi.

Mobile Number(s): +254 (0) 770410949

**Section A: Respondent Details**

1. Age: \_\_\_\_\_

2. Gender:

*Select one option only*

Male

Female

3. Place of residence: County/City:

\_\_\_\_\_

\_\_\_\_\_

\_\_\_\_\_

4. Level of Education

*Select one option only*

Primary Level

Secondary Level

Graduate Level

Post Graduate Level

5. What type of manure do you use in your farm

*Select one option only*

Organic manure from my cattle/self-made

Industry manufactured manure

I don't use manure

**Section B: Factors Need Transparency, Accountability and Distribution in the Food Supply**

**Chain**

1. Please indicate the extent to which you have embraced the below aspect in improving your produce traceability and safety, where 1-Very Small Extent; 2-Small Extent; 3-Medium; 4-Great Extent; 5-Very Great Extent

<b>Measure</b>	<b>1</b>	<b>2</b>	<b>3</b>	<b>4</b>	<b>5</b>
You use mobile service delivery to market and					

check pricing information					
You use tagging of the produce (RFID/bar code) for tracking					
You have a system to capture the source of manure and water usage					
You have a system to capture the details of the wholesaler who collected your produce					
You have strategies to control foodborne pathogens in your farm					

**Section C: Current Approaches Used To Enhance Food Traceability and Safety**

1. What approach (es) do you use to ensure your produce are traceable and safe? (*Select all that apply*)

- Produce Inspection
- Produce Audit
- Produce Recall and Enforcement
- Specify Other.....

2. Considering only the approaches above, in a scale of 1 to 5, rate the effectiveness of the existing operational performance approach used in your university? Where 1-Very low, 2-Below average, 3- average, 4-Above average, 5-Very high. (*State the rate for approaches used only*)

<b>Approach</b>	<b>1</b>	<b>2</b>	<b>3</b>	<b>4</b>	<b>5</b>
Produce Inspection					
Produce Audit					
Produce Recall and Enforcement					
Approach Specified.....					

3. Given the above answers, kindly rate the challenges you have experienced with them. Where where 1-Very Small Extent; 2-Small Extent; 3-Medium; 4-Great Extent; 5-Very Great Extent

Challenges	1	2	3	4	5
Produce traceability					
Produce Safety					

**Section D: Development of Block Chain Technology Driven System to Enhance Food**

**Traceability and Safety**

- Would you like to have a system that would enhance traceability and food safety of your produce?
  - Yes
  - No
- If Yes, please explain.....  
 .....  
 .....  
 .....  
 .....
- How would you like to access the system?
  - Web Application
  - Mobile phone application
  - Either would do
- Would you like to use the system to sell to customers directly or only to distributors?
  - Customers
  - Distributors
  - Both
- Would you like to buy farm input directly from producer or from wholesaler/distributor
  - Directly from producer
  - From wholesaler
  - Either would work

6. Would you like the system to have a single authentication method or would like a two-factor authentication?

Single Authentication

two-factor authentication



## **Appendix C: Food Processing Companies Questionnaire**

### **QUESTIONNAIRE FOR FOOD PROCESSING COMPANIES**

#### **Purpose**

The aim of this study is to develop a system using block chain technology that will inject transparency, and decentralization in the supply chain to enhance food traceability and safety in Kenya.

#### **Confidentiality**

The data and/or information collected shall be treated with utmost confidentiality and shall not be shared without your prior permission.

#### **Directions in responding to the Questionnaire:**

1. Please check all boxes that apply in each question.
2. References to “you” or “your” refer to your farm or you as an individual.
3. “System” means a web based portal that will enable farmer to make their produce traceable and hence safe for consumers in Kenya.
4. “Products” refers to farm produce that range from animal products to fruits to grains (maize, rice beans, wheat.)

#### **Correspondence/Inquiries:**

Mr. Lenjula Letitoiya Lesiit (lenjula@gmail.com)

P.O. Box XXX - 00100, Nairobi.

Mobile Number(s): +254 (0) 770410949

## **Section A: Respondent Details**

1. Gender: *Select one option only*
- Male
  - Female
2. Position in the Company *Select one option only*
- Executive
  - Upper Management
  - Middle Management
  - Worker
3. Level of Education *Select one option only*
- Primary Level
  - Secondary Level
  - Graduate Level
  - Post Graduate Level
4. Have your company ever registered foodborne crisis *Select one option only*
- Yes
  - No
  - Not sure
5. Did you find out at what stage the food was contaminated *Select one option only*
- Raw material to farm
  - Farm produce
  - Food processors
  - On transit
6. What did the company do in light of this information *Select one option only*
- Issue an alert to the public
  - Recalled the product

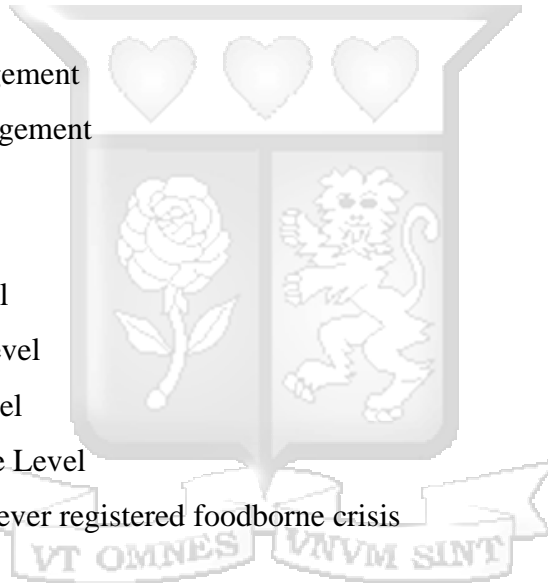

Nothing

**Section B: Current Approaches Used To Enhance Food Traceability and Safety**

1. The below are the currently employed approaches by food processors for traceable and safety. Which ones do your company employ? (*Select all that apply*)

- Unique identifies(tag and bar codes)
- Real Tracking of delivery tracks
- Distributed ledger technology
- Specify Other.....

2. Considering only the approaches selected above, in a scale of 1 to 5, rate the effectiveness of the existing approaches in ensuring food traceability and safety? Where 1-Very low, 2-Below average, 3- average, 4-Above average, 5-Very high. (*State the rate for approaches used only*)

<b>Approach</b>	<b>1</b>	<b>2</b>	<b>3</b>	<b>4</b>	<b>5</b>
Unique identifies(tag and bar codes)					
Real Tracking of delivery tracks					
Distributed ledger technology					
Approach Specified.....					

3. Given the above answers, kindly rate the challenges you have experienced with them. Where where1-Very Small Extent; 2-Small Extent; 3-Medium; 4-Great Extent;5-Very Great Extent

<b>Challenges</b>	<b>1</b>	<b>2</b>	<b>3</b>	<b>4</b>	<b>5</b>
<b>Produce traceability</b>					
<b>Produce Safety</b>					

**Section C: Development of Block Chain Technology Driven System to Enhance Food Traceability and Safety**

1. Would you like to have a system that would enhance traceability and food safety of your food; from farm to fork?

Yes

No

2. If Yes, please explain.....

.....

.....

.....

3. How would you like to access the system?

Web Application

Mobile phone application

Either would do

4. Would you like to use the system to by directly from a farmer or distributors/wholesaler?

Farmer

Distributors

Either would work

5. Would you like the system to have a single authentication method or would like a two-factor authentication?

Single Authentication

two-factor authentication

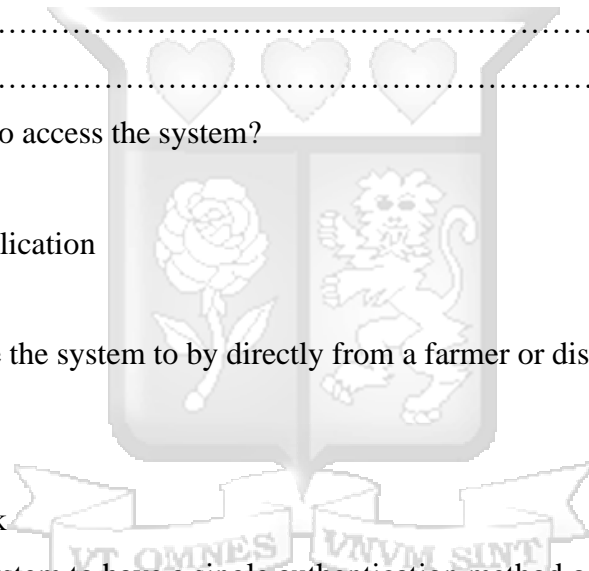

## **Appendix D: Customers of Farm Produce Questionnaire**

### **QUESTIONNAIRE FOR CUSTOMERS FO FARM PRODUCE IN KENYA**

#### **Purpose**

The aim of this study is to develop a system using block chain technology that will inject transparency, and decentralization in the supply chain to enhance food traceability and safety in Kenya.

#### **Confidentiality**

The data and/or information collected shall be treated with utmost confidentiality and shall not be shared without your prior permission.

#### **Directions in responding to the Questionnaire:**

5. Please check all boxes that apply in each question.
6. References to “you” or “your” refer to your farm or you as an individual.
7. “System” means a web based portal that will enable farmer to make their produce traceable and hence safe for consumers in Kenya.
8. “Products” refers to farm produce that range from animal products to fruits to grains (maize, rice beans, wheat.)

#### **Correspondence/Inquiries:**

Mr. Lenjula Letitoiya Lesiit (lenjula@gmail.com)

P.O. Box XXX - 00100, Nairobi.

Mobile Number(s): +254 (0) 770410949

**Section A: Respondent Details**

7. Age: \_\_\_\_\_

8. Gender:

- Male
- Female

*Select one option only*

9. Place of residence: County/City:

\_\_\_\_\_  
\_\_\_\_\_  
\_\_\_\_\_

10. Level of Education

- Primary Level
- Secondary Level
- Graduate Level
- Post Graduate Level

*Select one option only*

11. Have you ever been a victim of foodborne disease

- Yes
- No
- Not sure

*Select one option only*

12. Did you find out at what stage the food was contaminated

- Raw material to farm
- Farm produce
- Food processors
- On transit

*Select one option only*

**Section B: Upcoming Strategies in Transparency, Accountability and Distribution in the Food Supply Chain**

2. Below are some traceability and safety strategies that are becoming popular. Kindly rate which strategies you know or have witnessed farmers using, where 1-Very Small Extent; 2-Small Extent; 3-Medium; 4-Great Extent; 5-Very Great Extent

<b>Measure</b>	<b>1</b>	<b>2</b>	<b>3</b>	<b>4</b>	<b>5</b>
Farmer uses mobile service delivery to market and check pricing information					
Farmer uses tagging of the produce (RFID/bar code) for tracking					
Farmer have a system to capture the source of manure and water usage					
Farmer have a system to capture the details of the wholesaler who collected your produce					
Farmer have strategies to control foodborne pathogens in your farm					

**Section C: Current Approaches Used To Enhance Food Traceability and Safety**

3. The below are the currently employed approaches by farmers for traceable and safe. Which one are you familiar with? (*Select all that apply*)

Produce Inspection

Produce Audit

- Produce Recall and Enforcement
- Specify Other.....

4. Considering only the approaches selected above, in a scale of 1 to 5, rate the effectiveness of the existing approaches in ensuring food traceability and safety? Where 1-Very low, 2-Below average, 3- average, 4-Above average, 5-Very high. (*State the rate for approaches used only*)

<b>Approach</b>	<b>1</b>	<b>2</b>	<b>3</b>	<b>4</b>	<b>5</b>
Produce Inspection					
Produce Audit					
Produce Recall and Enforcement					
Approach Specified.....					

4. Given the above answers, kindly rate the challenges you have experienced with them. Where where1-Very Small Extent; 2-Small Extent; 3-Medium; 4-Great Extent;5-Very Great Extent

<b>Challenges</b>	<b>1</b>	<b>2</b>	<b>3</b>	<b>4</b>	<b>5</b>
<b>Produce traceability</b>					
<b>Produce Safety</b>					

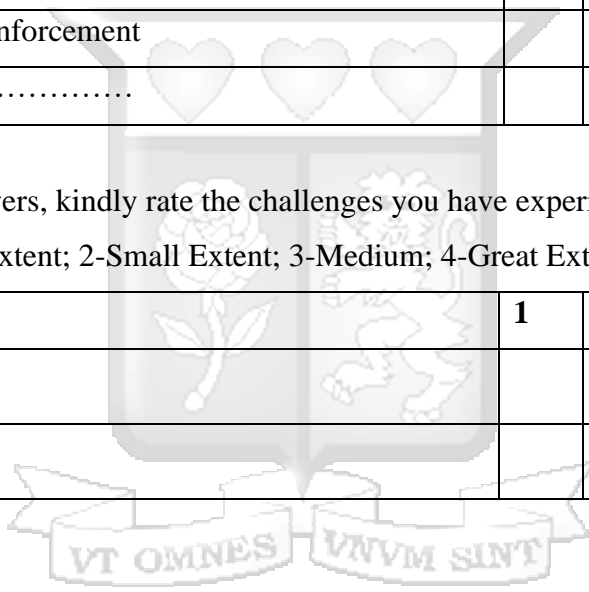

**Section D: Development of Block Chain Technology Driven System to Enhance Food Traceability and Safety**

6. Would you like to have a system that would enhance traceability and food safety of your food; from farm to fork?

- Yes
- No

7. If Yes, please explain.....  
 .....  
 .....

.....  
8. How would you like to access the system?

- Web Application
- Mobile phone application
- Either would do

9. Would you like to use the system to by directly from a farmer or distributors/wholesaler?

- Farmer
- Distributors
- Either would work

10. Would you like the system to have a single authentication method or would like a two-factor authentication?

- Single Authentication
- two-factor authentication

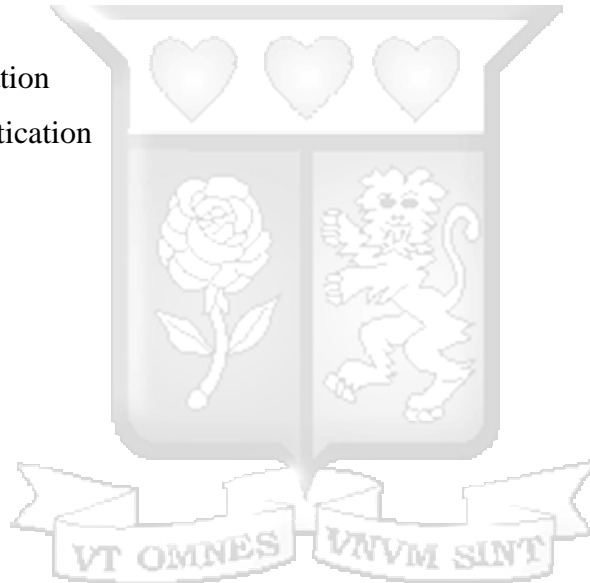



## Appendix E: NACOSTI Research Authorization Letter



### NATIONAL COMMISSION FOR SCIENCE, TECHNOLOGY AND INNOVATION

Telephone: +254-20-2213471,  
2241349, 3310571, 2219420  
Fax: +254-20-318245, 318249  
Email: dg@nacosti.go.ke  
Website: www.nacosti.go.ke  
When replying please quote

NACOSTI, Upper Kabete  
Off Waiyaki Way  
P.O. Box 30623-00100  
NAIROBI-KENYA

Ref: No. **NACOSTI/P/19/56014/30016**

Date: **29<sup>th</sup> May, 2019.**

Lenjula Letitoiya Lesiit  
Strathmore University  
P.O. Box 59857 00200  
**NAIROBI.**

#### **RE: RESEARCH AUTHORIZATION**

Following your application for authority to carry out research on *“Block chain technology to enhance food traceability and safety; case study of Agriculture industry in Kenya.”* I am pleased to inform you that you have been authorized to undertake research in **Nairobi County** for the period ending **27<sup>th</sup> May, 2020.**

You are advised to report to **the County Commissioner and the County Director of Education, Nairobi County** before embarking on the research project.

Kindly note that, as an applicant who has been licensed under the Science, Technology and Innovation Act, 2013 to conduct research in Kenya, you shall deposit **a copy** of the final research report to the Commission within **one year** of completion. The soft copy of the same should be submitted through the Online Research Information System.

  
**BONIFACE WANYAMA**  
**FOR: DIRECTOR-GENERAL/CEO**

Copy to:  
The County Commissioner  
Nairobi County.

The County Director of Education  
Nairobi County.

## Appendix F: NACOSTI Research Permit

**THIS IS TO CERTIFY THAT:** **Permit No<sup>o</sup> : NACOSTI/P/19/56014/30016**  
**MR. LENJULA LETITOIYA LESIIT** **Date Of Issue : 29th May,2019**  
**of STRATHMORE UNIVERSITY,** **Fee Received :Ksh 1000**  
**61989-200 NAIROBI,has been permitted**  
**to conduct research in Nairobi County**

**on the topic: BLOCK CHAIN**  
**TECHNOLOGY TO ENHANCE FOOD**  
**TRACEABILITY AND SAFETY; CASE**  
**STUDY OF AGRICULTURE INDUSTRY IN**  
**KENYA**

**for the period ending:**  
**27th May,2020**

*Lenjula Letitoiya Lesiit*  
**Applicant's**  
**Signature**

*[Signature]*  
**Director General**  
**National Commission for Science,**  
**Technology & Innovation**

